



US008863411B2

(12) **United States Patent**
Berger et al.

(10) **Patent No.:** **US 8,863,411 B2**

(45) **Date of Patent:** ***Oct. 21, 2014**

(54) **ARTICLE OF FOOTWEAR WITH A
DETACHABLE WRAP**

(71) Applicant: **NIKE, Inc.**, Beaverton, OR (US)

(72) Inventors: **Tiffany J. Berger**, Portland, OR (US);
Marci S. DuChene, Tigard, OR (US);
Nicole Mueller, Portland, OR (US)

(73) Assignee: **NIKE, Inc.**, Beaverton, OR (US)

(*) Notice: Subject to any disclaimer, the term of this patent is extended or adjusted under 35 U.S.C. 154(b) by 0 days.

This patent is subject to a terminal disclaimer.

(21) Appl. No.: **13/927,838**

(22) Filed: **Jun. 26, 2013**

(65) **Prior Publication Data**

US 2014/0007458 A1 Jan. 9, 2014

Related U.S. Application Data

(62) Division of application No. 12/749,820, filed on Mar. 30, 2010, now Pat. No. 8,479,415.

(51) **Int. Cl.**

A43B 3/24 (2006.01)
A43C 1/00 (2006.01)
A43B 7/14 (2006.01)
A43B 7/18 (2006.01)

(52) **U.S. Cl.**

CPC **A43B 3/24** (2013.01); **A43B 7/1495**
(2013.01); **A43B 7/18** (2013.01); **A43C 1/00**
(2013.01)
USPC **36/101**; 36/50.1; 36/127

(58) **Field of Classification Search**

CPC A43B 3/24; A43B 7/1495; A43B 7/20;
A43B 7/142; A43C 1/00
USPC 36/101, 127, 50.1, 91, 170; 602/66
See application file for complete search history.

(56) **References Cited**

U.S. PATENT DOCUMENTS

1,627,596 A * 5/1927 Cutshaw 602/66
3,994,080 A 11/1976 Flanagan, Jr. et al.
4,227,321 A * 10/1980 Kling et al. 36/91
4,507,882 A 4/1985 Harrell
4,611,416 A 9/1986 Lin
4,697,362 A 10/1987 Wasserman

(Continued)

FOREIGN PATENT DOCUMENTS

CN 102970889 3/2013
EP 2552268 2/2013

(Continued)

OTHER PUBLICATIONS

Invitation to Pay Additional Fees and, Where Applicable, Protest Fee mailed Jul. 20, 2011 in International Application No. PCT/US2011/030328.

(Continued)

Primary Examiner — Ted Kavanaugh

(74) *Attorney, Agent, or Firm* — Plumsea Law Group, LLC

(57) **ABSTRACT**

An article of footwear with a detachable wrap is disclosed. The detachable wrap removably attaches to a lacing area of an upper and extends under the article of footwear through a channel in a midsole of the sole structure. The detachable wrap may change the appearance of the article of footwear and additionally provide support to a foot of the wearer.

19 Claims, 8 Drawing Sheets

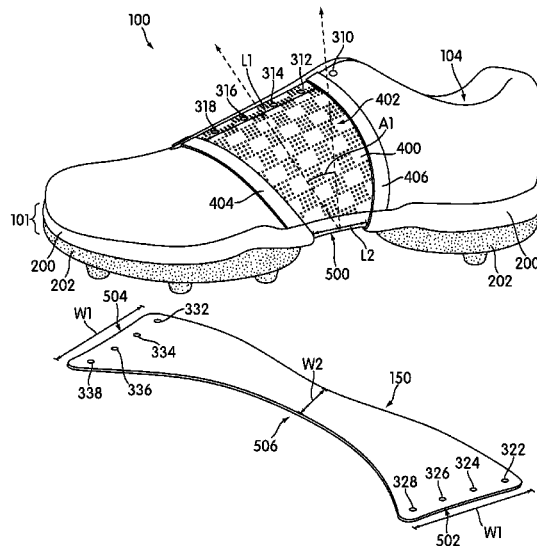

(56)

References Cited

U.S. PATENT DOCUMENTS

4,852,276 A 8/1989 Savoca et al.
 4,888,887 A 12/1989 Solow
 5,109,614 A * 5/1992 Curry 36/100
 5,497,564 A * 3/1996 Allen et al. 36/50.1
 5,692,319 A * 12/1997 Parker et al. 36/50.1
 5,778,564 A 7/1998 Kettner
 5,848,484 A * 12/1998 Dupree et al. 36/101
 6,212,797 B1 4/2001 Merry et al.
 6,817,117 B1 11/2004 Campbell
 7,089,691 B1 8/2006 Silvera
 7,117,615 B2 * 10/2006 Gerber 36/101
 7,165,342 B2 1/2007 Sheen
 D540,026 S 4/2007 Lane, III et al.
 7,325,337 B2 2/2008 Cox et al.
 7,328,527 B2 2/2008 Goldman
 7,793,435 B1 9/2010 Ruth
 8,065,821 B1 * 11/2011 Reid 36/100
 2002/0174569 A1 * 11/2002 Tsai 36/101

2005/0126042 A1 * 6/2005 Baier et al. 36/50.1
 2005/0138846 A1 * 6/2005 O'Connor 36/72 B
 2006/0248753 A1 * 11/2006 Welsh 36/101
 2011/0239486 A1 10/2011 Berger et al.
 2014/0013621 A1 * 1/2014 Dupree et al. 36/100

FOREIGN PATENT DOCUMENTS

FR 2793339 11/2000
 WO 9948395 9/1999
 WO 2008008158 1/2008
 WO 2011126837 10/2011

OTHER PUBLICATIONS

International Search Report and Written Opinion mailed Oct. 11, 2012 in International Application No. PCT/US2011/030328.
 International Preliminary Report on Patentability (including Written Opinion of the ISA) mailed Nov. 1, 2012, in International Application No. PCT/US2011/030328.

* cited by examiner

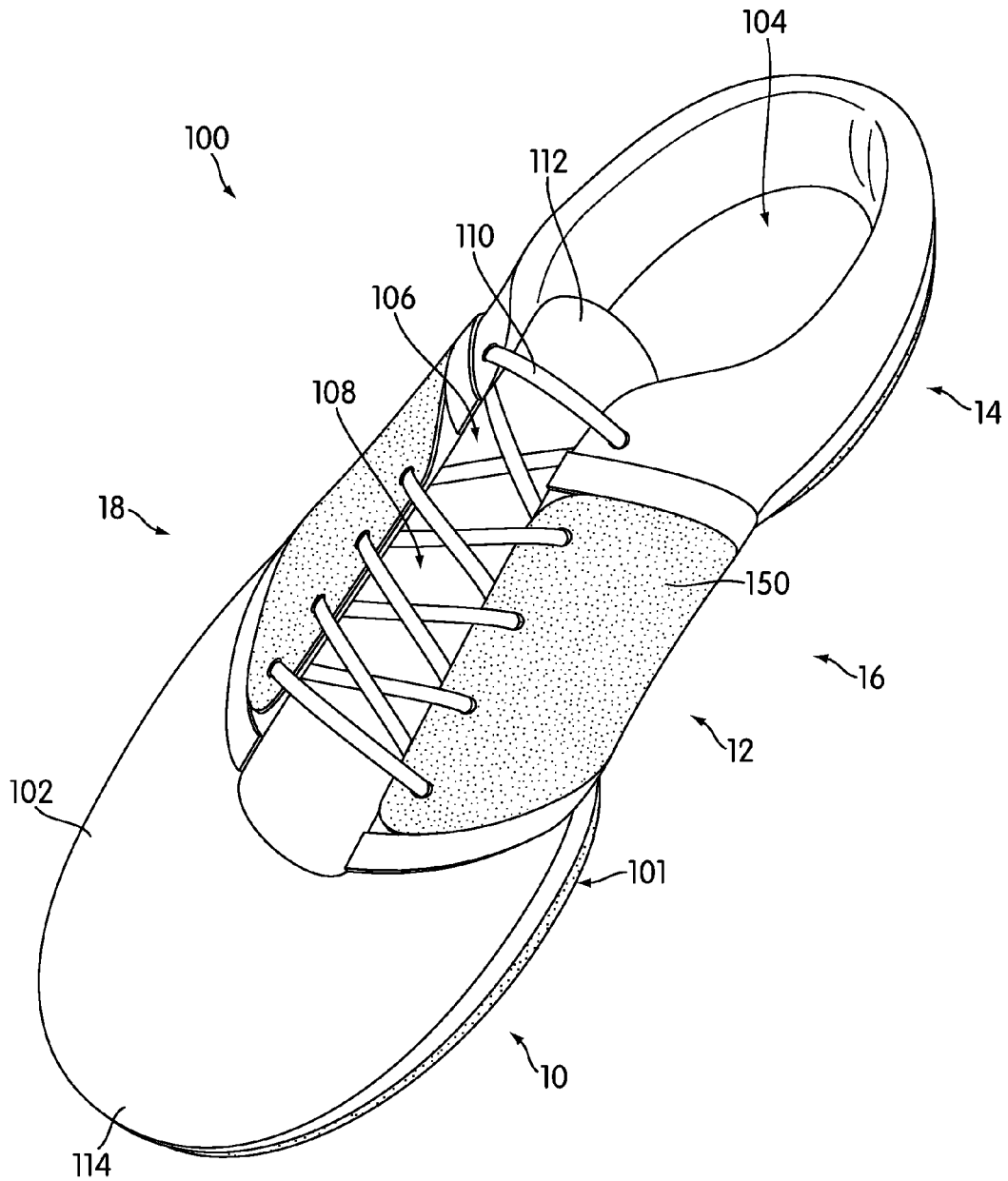

FIG. 1

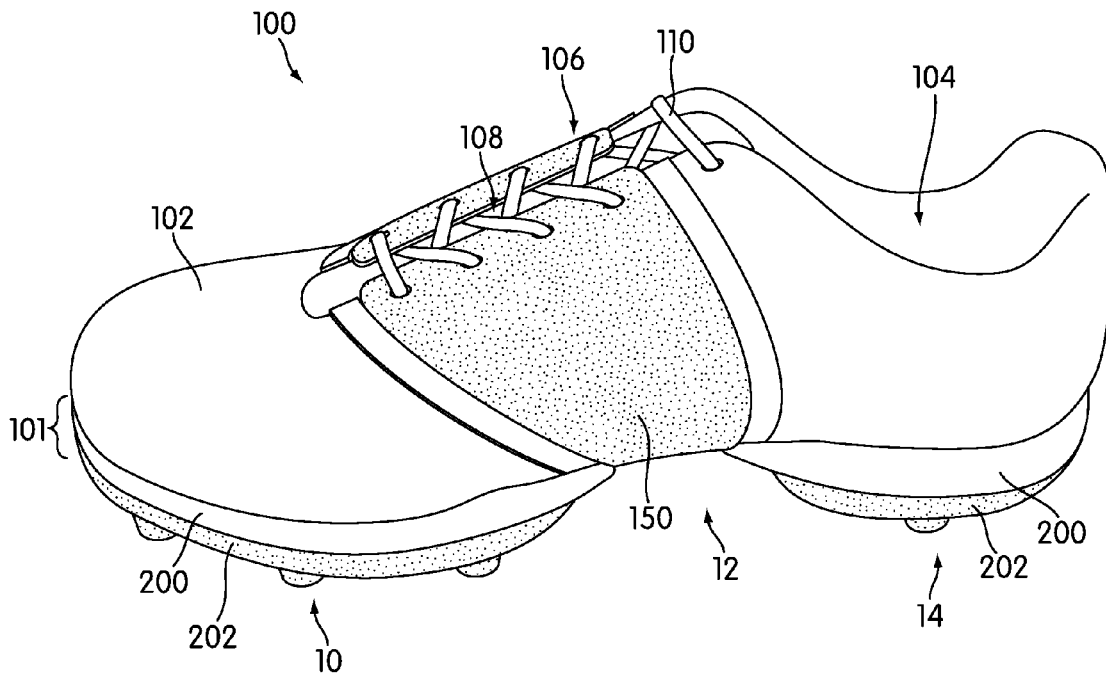

FIG. 2

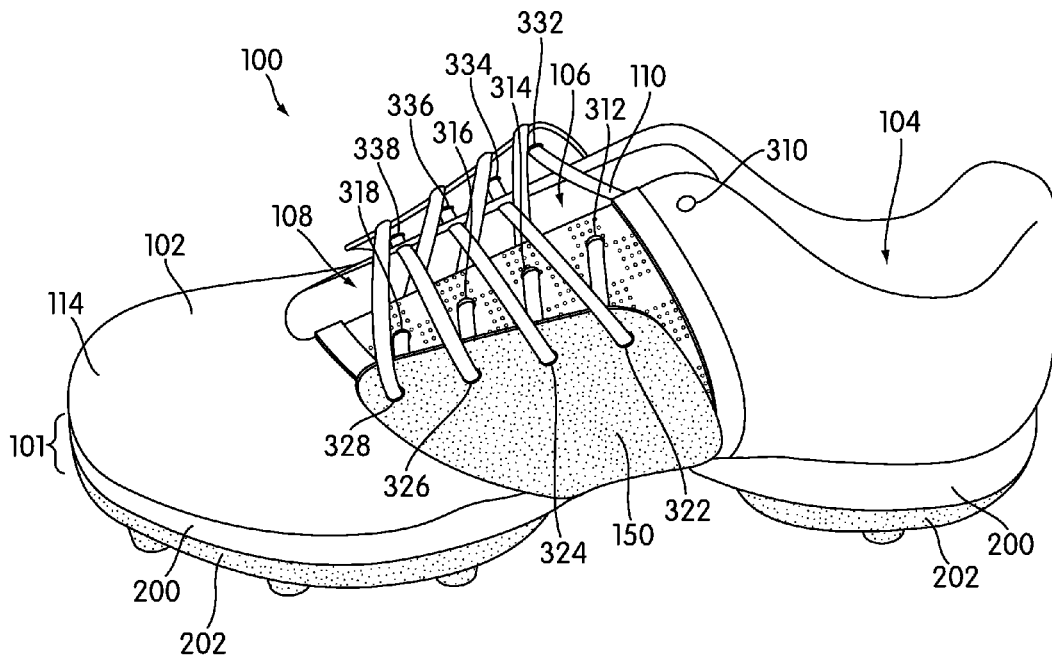

FIG. 3

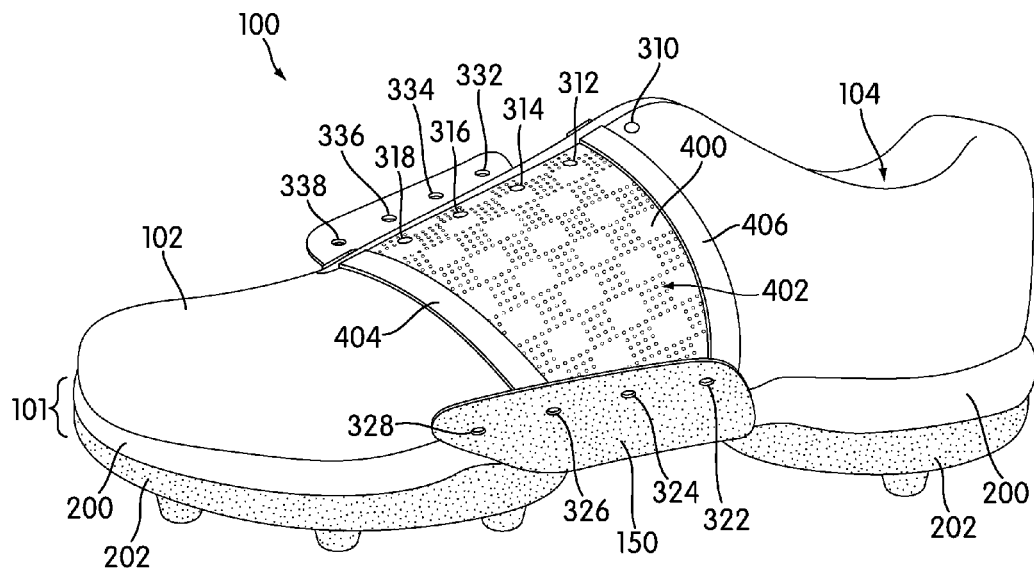

FIG. 4

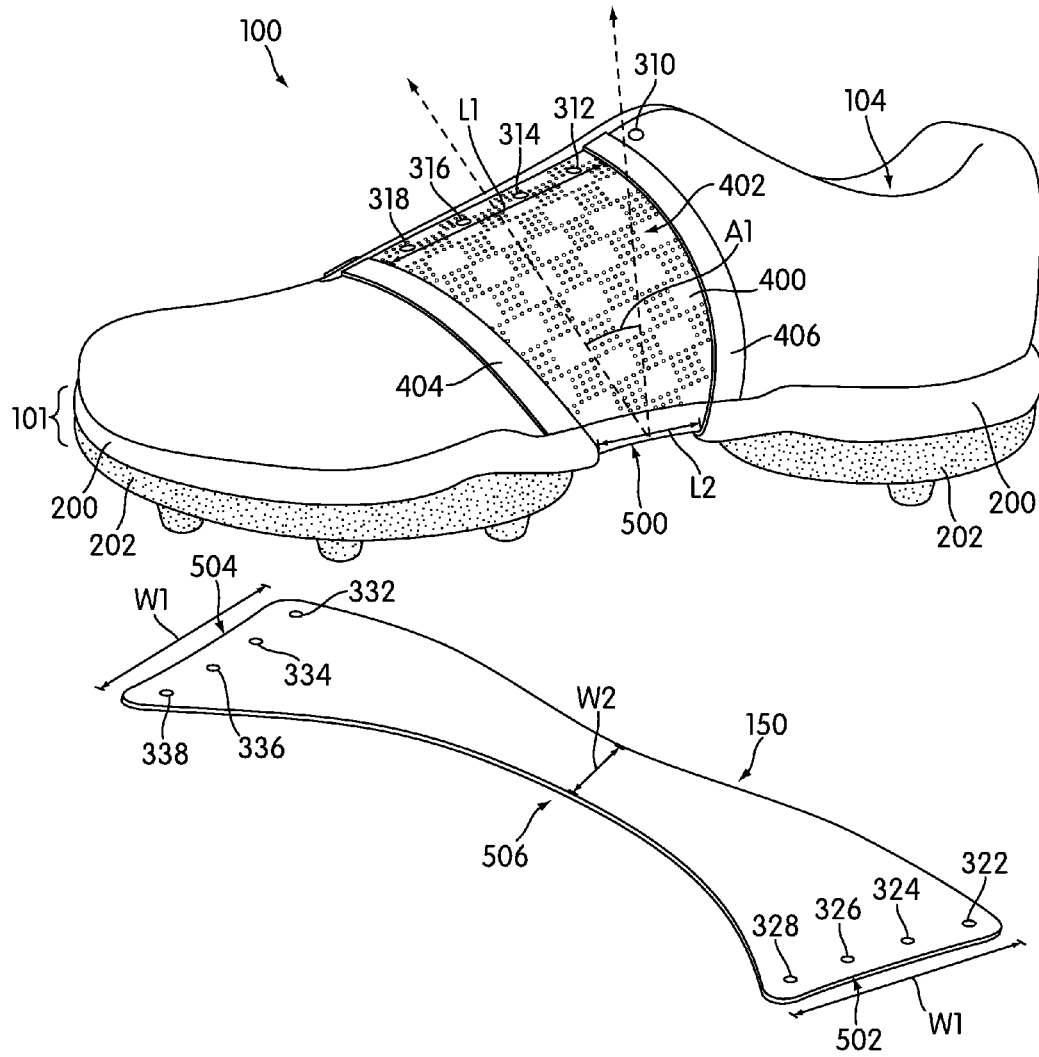

FIG. 5

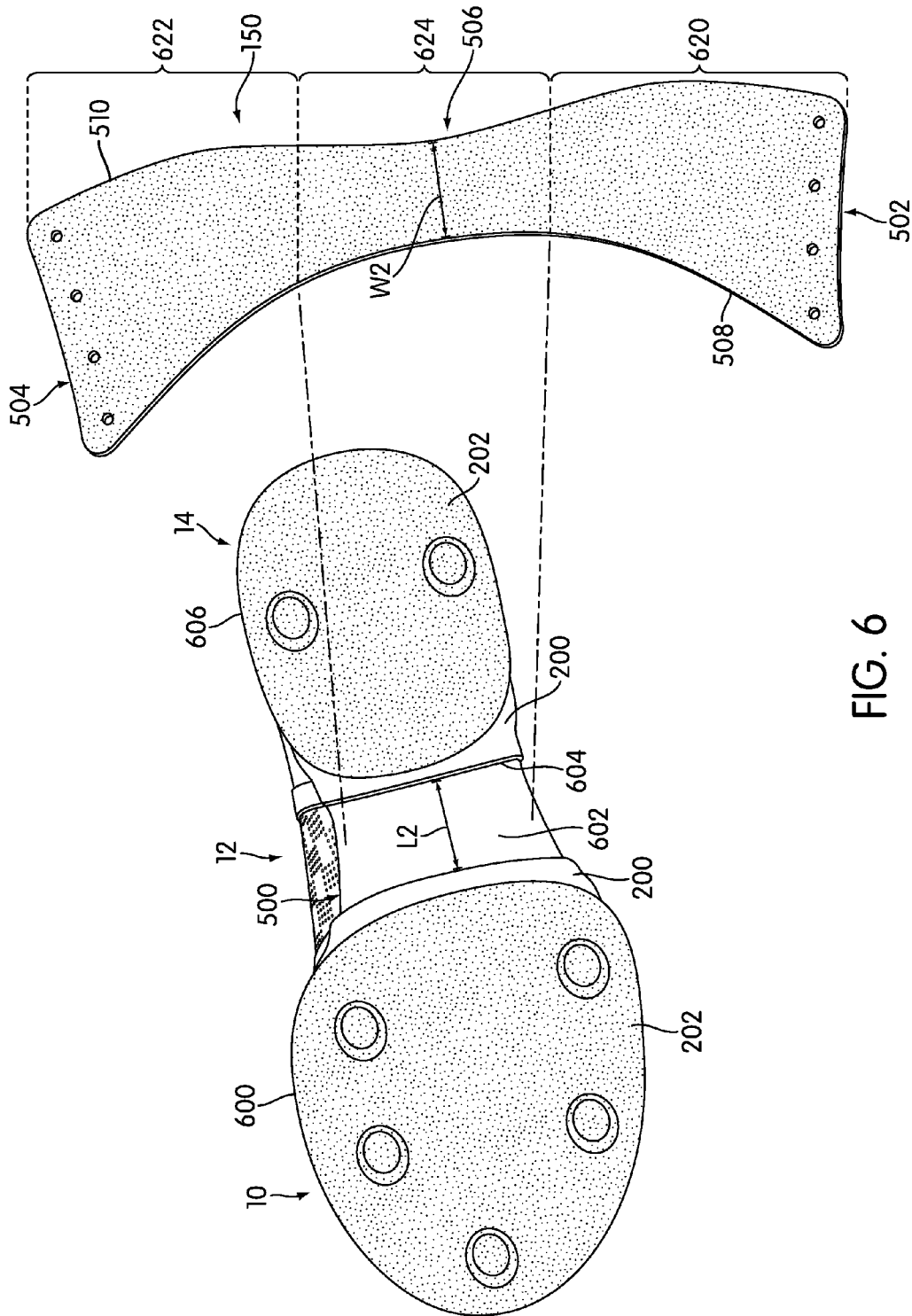

FIG. 6

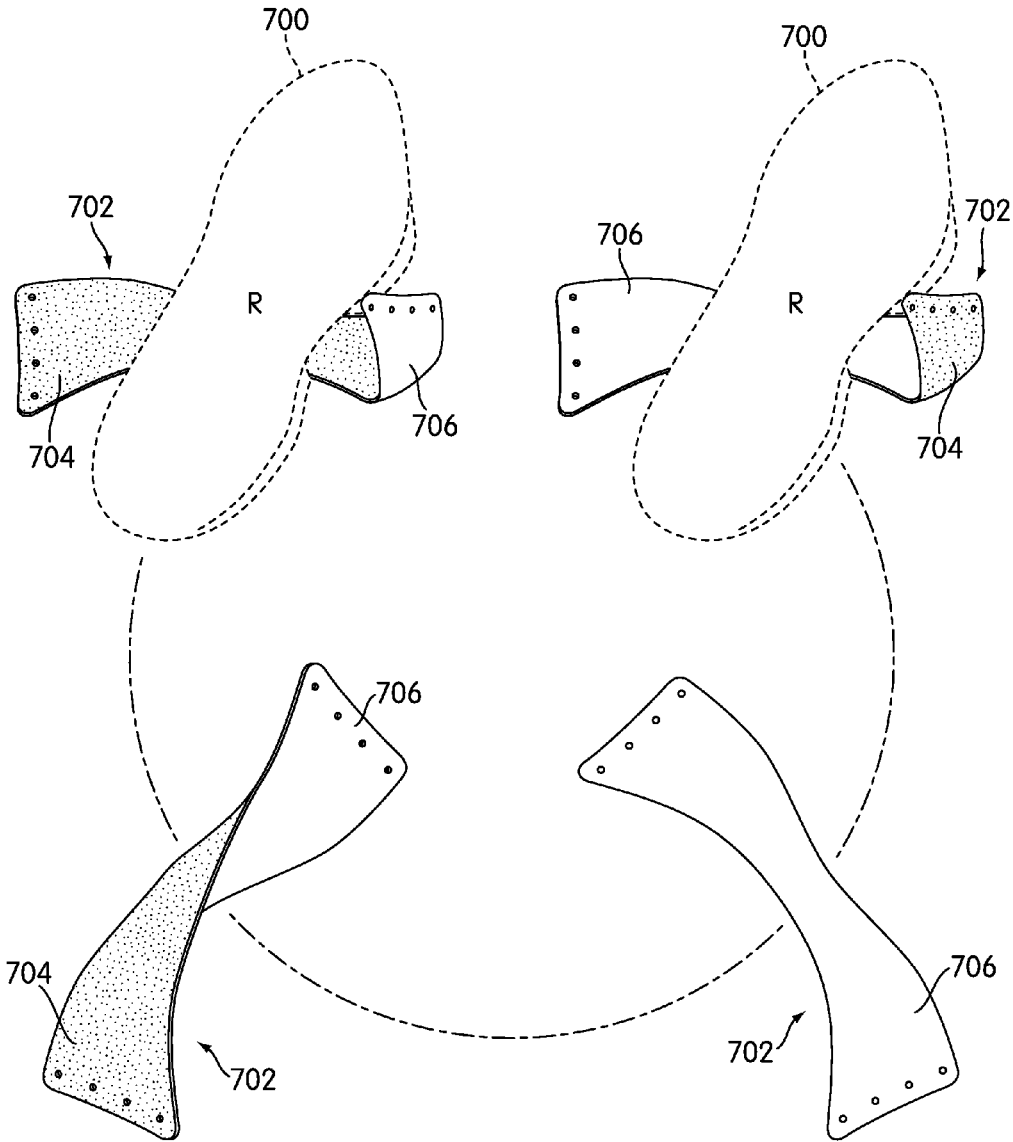

FIG. 7

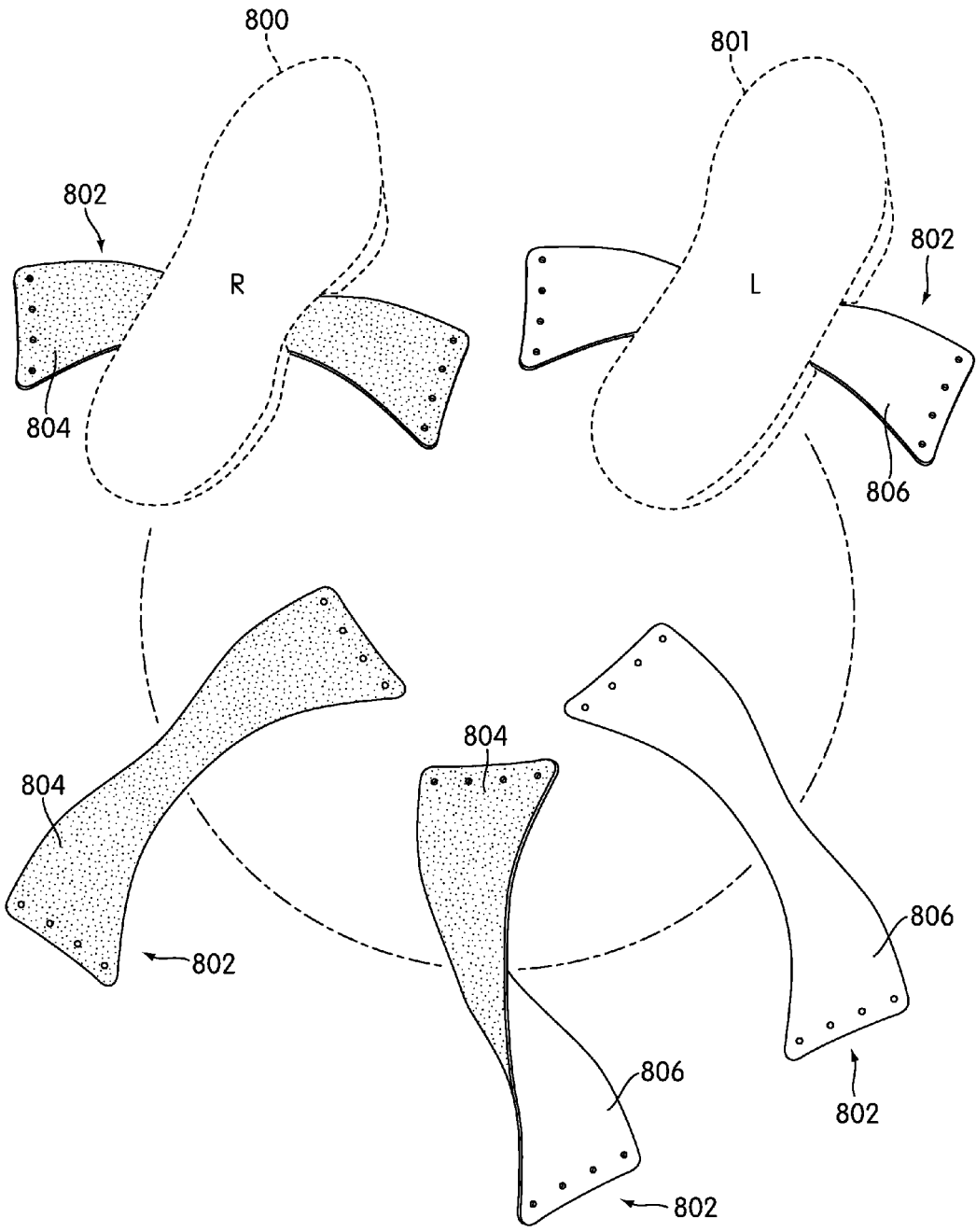

FIG. 8

1

ARTICLE OF FOOTWEAR WITH A DETACHABLE WRAP

CROSS REFERENCE TO RELATED APPLICATION

This application is a division of U.S. patent application Ser. No. 12/749,820, filed Mar. 30, 2010 (issued as U.S. Pat. No. 8,479,415 and previously published as U.S. Patent App. Pub. No. US 2011/0239486 A1 on Oct. 6, 2011), which is incorporated by reference in its entirety.

BACKGROUND

The present invention relates generally to an article of footwear, and more particularly to an article of footwear with a detachable wrap.

Articles of footwear have been provided with decorative coverings that allow a wearer to change the appearance of the article. Typically, these coverings fit over portions of the article. A wearer may change the coverings to alter the visual appearance of the article.

There is a need in the art for a detachable wrap that provides a different appearance for an article of footwear and is also capable of providing support to the foot of a wearer.

SUMMARY

In one aspect, the invention provides an article of footwear, comprising: an upper, including a lacing area disposed on a lateral side and a medial side of the upper; a sole structure; a wrap member, including a first edge disposed at a first longitudinal end of the wrap member, a second edge disposed at a second longitudinal end of the wrap member, and a midsection portion disposed generally between the first edge and the second edge; wherein the wrap member is removably attached to the upper at the lacing area on each of the lateral side and the medial side and extends under a portion of the sole structure; and wherein the wrap member tapers from a first width associated with each of the first edge and the second edge to a second width associated with the midsection portion.

In another aspect, the invention provides an article of footwear, comprising: an upper, including a lacing area with a plurality of eyelets disposed on a lateral side and a medial side of the upper; a sole structure; a wrap member, including a first edge disposed at a first longitudinal end of the wrap member, a second edge disposed at a second longitudinal end of the wrap member, and a midsection portion disposed generally between the first edge and the second edge; wherein the first edge and the second edge each include a plurality of lacing holes that are spaced apart to be capable of substantially aligning with the plurality of eyelets; wherein the wrap member is removably attached to the upper at the lacing area on each of the lateral side and the medial side by a lace disposed through the plurality of eyelets and the plurality of lacing holes; and wherein the midsection portion of the wrap member extends under a portion of the sole structure.

In another aspect, the invention provides a wrap member for use with an article of footwear, comprising: a first edge disposed at a first longitudinal end of the wrap member; a second edge disposed at a second longitudinal end of the wrap member; a midsection portion disposed generally between the first edge and the second edge; wherein the wrap member is substantially symmetric along the lateral axis so that the first edge and the second edge generally align when the wrap member is folded in half; and wherein the wrap member is

2

adapted to be removably attached to an upper of the article of footwear and to extend under a portion of a sole structure of the article of footwear.

In another aspect, the wrap member extends under the portion of the sole structure in a channel disposed in the midsole at a location between the outsole in the forefoot region and the heel region.

In another aspect, the channel is located so as to be substantially aligned with an arch of a foot of a wearer of the article of footwear.

In another aspect, the wrap member is adapted to be interchangeable between each article of footwear in a pair of footwear.

Other systems, methods, features and advantages of the invention will be, or will become apparent to one of ordinary skill in the art upon examination of the following figures and detailed description. It is intended that all such additional systems, methods, features and advantages be included within this description and this summary, be within the scope of the invention, and be protected by the following claims.

BRIEF DESCRIPTION OF THE DRAWINGS

The invention can be better understood with reference to the following drawings and description. The components in the figures are not necessarily to scale, emphasis instead being placed upon illustrating the principles of the invention. Moreover, in the figures, like reference numerals designate corresponding parts throughout the different views.

FIG. 1 is an isometric view of an exemplary embodiment of an article of footwear including a detachable wrap member;

FIG. 2 is a side view of an exemplary embodiment of an article of footwear including a detachable wrap member;

FIG. 3 is a side view of an exemplary embodiment of an article of footwear including a detachable wrap member in a loose condition;

FIG. 4 is a side view of an exemplary embodiment of an article of footwear including a detachable wrap member in a partially removed condition;

FIG. 5 is a side exploded view of an exemplary embodiment of an article of footwear including a detachable wrap member;

FIG. 6 is a bottom exploded view of an exemplary embodiment of an article of footwear including a detachable wrap member;

FIG. 7 is a representative view of an exemplary embodiment of a reversible wrap member; and

FIG. 8 is a representative view of an exemplary embodiment of an interchangeable and reversible wrap member.

DETAILED DESCRIPTION

FIGS. 1 through 6 illustrate views of an embodiment of article of footwear **100**. For clarity, the following detailed description discusses an embodiment in the form of a golf shoe, but it should be noted that the present invention could take the form of any article of footwear including, but not limited to, soccer shoes, football shoes, rugby shoes, baseball shoes, basketball shoes, sneakers, hiking boots, as well as other kinds of articles of footwear. As shown in FIG. 1, article of footwear **100**, also referred to simply as article **100**, is intended to be used with a right foot; however, it should be understood that the following discussion may equally apply to a mirror image of article of footwear **100** that is intended for use with a left foot.

Referring to FIGS. 1 through 6, for purposes of reference, article **100** may include forefoot region **10**, midfoot region **12**

and heel region **14**. Forefoot region **10** may be generally associated with the toes and joints connecting the metatarsals with the phalanges. Midfoot region **12** may be generally associated with the arch of a foot. Likewise, heel region **14** may be generally associated with the heel of a foot, including the calcaneus bone. In addition, article **100** may include medial side **16** and lateral side **18**. In particular, medial side **16** and lateral side **18** may be opposing sides of article **100**. Furthermore, both medial side **16** and lateral side **18** may extend through forefoot region **10**, midfoot region **12** and heel region **14**.

It will be understood that forefoot region **10**, midfoot region **12** and heel region **14** are only intended for purposes of description and are not intended to demarcate precise regions of article **100**, but rather, to describe relative positions. Likewise, medial side **16** and lateral side **18** are intended to represent generally two sides of an article, rather than precisely demarcating article **100** into two halves. In addition, forefoot region **10**, midfoot region **12** and heel region **14**, as well as medial side **16** and lateral side **18**, can also be applied to individual components of an article, such as a sole structure and/or an upper.

For consistency and convenience, directional adjectives are employed throughout this detailed description corresponding to the illustrated embodiments. The term “longitudinal” as used throughout this detailed description and in the claims refers to a direction extending a length of an article. In some cases, the longitudinal direction may extend from a forefoot region to a heel region of the article. Also, the term “lateral” as used throughout this detailed description and in the claims refers to a direction extending a width of an article. In other words, the lateral direction may extend between a medial side and a lateral side of an article. It will be understood that each of these directional adjectives may be applied to individual components of an article, such as a sole structure and/or an upper.

Article of footwear **100**, may include upper **102**. Generally, upper **102** may be any type of upper. In particular, upper **102** may have any design, shape, size and/or color. For example, in embodiments where article **100** is a golf shoe, upper **102** could be a low top upper. In embodiments where article **100** is a basketball shoe, upper **102** could be a high top upper that is shaped to provide high support on an ankle. Generally, upper **102** may be made from any suitable material, including a material that includes, but is not limited to, nylon, natural leather, synthetic leather, natural rubber, or synthetic rubber. In some cases, upper **102** can be made of any suitable knitted, woven or non-woven material.

For purposes of clarity, only some portions of upper **102** are discussed in the exemplary embodiments. It should be understood that upper **102** may include other provisions that are known in the art for assisting in walking, running or other athletic maneuvers.

Typically, upper **102** may be configured to receive a foot of a wearer. In some embodiments, upper **102** includes entry hole or throat opening **104** configured to receive a foot of a wearer. With this arrangement, entry hole or throat opening **104** may allow a foot to be inserted into an interior of upper **102**.

In some embodiments, upper **102** may be associated with sole structure **101**. Sole structure **101** is secured to upper **102** and extends between the foot and the ground when article **100** is worn. In different embodiments, sole structure **101** may include different components. For example, sole structure **101** may include an outsole, a midsole, and/or an insole. In some cases, one or more of these components may be optional. Sole structure **101** may be made from any suitable

material, including a material that includes, but is not limited to, elastomers, siloxanes, natural rubber, other synthetic rubbers, aluminum, steel, natural leather, synthetic leather, or plastics.

In some embodiments, sole structure **101** may be configured to provide traction for article **100**. In addition to providing traction, sole structure **101** may attenuate ground reaction forces when compressed between the foot and the ground during walking, running or other ambulatory activities. The configuration of sole structure **101** may vary significantly in different embodiments to include a variety of conventional or non-conventional structures. In some cases, the configuration of sole structure **101** can be configured according to one or more types of ground surfaces on which sole structure **101** may be used. Examples of ground surfaces include, but are not limited to: natural turf, synthetic turf, dirt, as well as other surfaces.

In some embodiments, upper **102** may include shoe fastening system **106**. Shoe fastening system **106** may be used to tighten upper **102** to a foot. Examples of shoe fastening systems include, but are not limited to, laces, buckles, hook and loop fasteners (such as Velcro®) as well as any other types of fastening systems. In one embodiment, shoe fastening system **106** includes lace **110**. Additionally, shoe fastening system **106** may include lacing area **108**. Lacing area **108** may be a gap or opening in upper **102** that extends from entry hole **104** into forefoot region **10**. In this embodiment, lace **110** may be configured to change the size of lacing area **108**, which may further adjust the size of upper **102**.

In this embodiment, article of footwear **100** includes lace **110** to secure a foot within upper **102**. Generally, lace **110** may be configured with any length necessary to fasten upper **102**. In addition, lace **110** may be configured in a particular shape visible in a cross section of lace **110**. In some embodiments, lace **110** may include a substantially flat cross section. In other embodiments, lace **110** may be configured with a substantially rounded cross section.

Generally, lace **110** may comprise any material, including a material that includes, but is not limited to, leather, cotton, jute, hemp, or synthetic fibers. Additionally, lace **110** may be coated with a material to increase friction in order to keep lace **110** fastened. In some cases, lace **110** may include elastic portions.

In order to fasten upper **102**, lace **110** may be configured to span lacing area **108**. Generally, lacing area **108** may be disposed in various locations on upper **102**. In some embodiments, lacing area **108** may be disposed between medial side **16** and lateral side **18** of upper **102**. In other embodiments, lacing area **108** may be disposed asymmetrically so that a portion of lacing area **108** is disposed entirely within medial side **16** and lateral side **18**. In one exemplary embodiment, lacing area **108** may be disposed generally along a centerline between medial side **16** and lateral side **18** of upper **102**.

In some embodiments, lacing area **108** may also be associated with tongue **112**. Preferably, tongue **112** is also associated with toe portion **114** of upper **102**. Typically, tongue **112** may be fixedly attached to toe portion **114** and disposed within lacing area **108**. However, in other cases, tongue **112** may be removable.

Generally, tongue **112** could have any design, shape, size and/or color. In some cases, tongue **112** may provide a particular aesthetic appearance for article **100**. In addition, tongue **112** may include padding or other provisions to increase comfort for a foot when lace **110** fastens upper **102** around a foot.

In some embodiments, lacing area **108** may include provisions for threading lace **110**. In some embodiments, lacing

5

area **108** may include a plurality of eyelets to receive lace **108** medial side **16** and lateral side **18**. The term “eyelet” as used throughout this detailed description and in the claims refers to a structure configured to receive a portion of a lace in an article of footwear. In some embodiments, an eyelet may be a small hole or perforation. In some cases, an eyelet may be a hole that is reinforced with a material, including a material that includes, but is not limited to, metal, cord, fabric or leather. In other embodiments, an eyelet may be an opening formed by a loop of material, including a material that includes, but is not limited to, fabric, cord, leather or metal.

In some embodiments, eyelets may be arranged in eyelet pairs. An eyelet pair may include an eyelet on a medial side of an upper associated with a second eyelet disposed on a lateral side of an upper. In some cases, an eyelet pair may be aligned in a lateral direction on a medial side and a lateral side of an upper. Furthermore, multiple eyelet pairs may be organized into a set of eyelets.

Article **100** may include one or more provisions for altering the appearance of article **100**. In some cases, one or more portions of article **100** may be changed to alter the appearance of article **100**. In some embodiments, wrap member **150** may be associated with article **100**. Wrap member **150** may be provided to alter the appearance of article **100**. In an exemplary embodiment, wrap member **150** may be removable. In other embodiments, wrap member **150** may be fixed.

As shown in FIG. 2, in this embodiment, wrap member **150** may be removably attached to upper **102** at lacing area **108** on each of medial side **16** and lateral side **18**, as further described below. In this embodiment, wrap member **150** extends under a portion of sole structure **101**. In one embodiment, wrap member **150** extends under a portion of sole structure at midfoot region **12**. In an exemplary embodiment, wrap member **150** may be configured to give article **100** a saddle shoe appearance. In other embodiments, wrap member **150** may provide support to an arch of a foot of a wearer.

In one embodiment, wrap member may be constructed of an elastic material. With this arrangement, wrap member may be configured to provide support to an arch of a foot of a wearer. In various embodiments, wrap member **150** may be constructed of different materials, including a material that includes, but is not limited to, natural leather, synthetic leather, natural fibers, rubber, elastic fibers, as well as other types of materials. In some cases, portions of wrap member **150** may be constructed of different materials. In some embodiments, portions of wrap member **150** may have different characteristics, including, but not limited to: color, text, printed design, reflectivity, roughness, and/or material.

In some embodiments, sole structure **101** may include a midsole **200** and an outsole **202**. In other embodiments, sole structure **101** may additionally include an insole. In this embodiment, midsole **200** may be attached to a lower area of upper **102**. Midsole **200** may be attached to upper **102** using any suitable attachment mechanism, including, but not limited to: stitching, adhesive bonding, and/or heat bonding. Midsole **200** may extend through each of forefoot region **10**, midfoot region **12**, and/or heel region **104** between medial side **16** and lateral side **18**.

In one exemplary embodiment, midsole **200** may be constructed of a polymer foam material, including, but not limited to polyurethane or ethylvinylacetate, that attenuates ground reaction forces as sole structure **101** is compressed between the foot and the ground. In other embodiments, midsole **200** may be constructed from any suitable material, including a material that includes, but is not limited to, elastomers, siloxanes, natural rubber, other synthetic rubbers, and/or plastics.

6

As shown in FIG. 2, midsole **200** may extend between upper **102** and outsole **202**. In some embodiments, outsole **202** may be attached to midsole **200** using any suitable attachment mechanism. In other embodiments, portions of midsole **200** and/or outsole **202** may be integrally formed from one or more materials. In one exemplary embodiment, sole structure **101** may be constructed using injection molding to form integral midsole **200** and outsole **202**. In some embodiments, outsole **202** may be constructed from natural or synthetic rubber. In different embodiments, outsole **202** may be constructed from any suitable durable and wear-resistant material, including a material that includes, but is not limited to, elastomers, siloxanes, natural rubber, other synthetic rubbers, and/or plastics.

Referring now to FIG. 3, in an exemplary embodiment, article of footwear **100** may include provisions to adjust wrap member **150** to a desired level of comfort and support. In some embodiments, the adjustment of wrap member **150** may provide some customization of the width of article **100**. Generally, tightening wrap member **150** around a foot may be accomplished using various mechanisms. In an exemplary embodiment, wrap member **150** may be associated with shoe fastening system **106** of upper **102**. In some embodiments, wrap member **150** may include an attachment system that corresponds to shoe fastening system **106**.

Shoe fastening system **106** on upper **102** may include at least one eyelet. In this embodiment, medial side **16** of upper **102** may include a first eyelet **310**, a second eyelet **312**, a third eyelet **314**, a fourth eyelet **316**, and a fifth eyelet **318** disposed along lacing area **108**. In this embodiment, first eyelet **310** is disposed adjacent to entry hole **104**. Similarly, fifth eyelet **318** is disposed adjacent to toe portion **114**. Second eyelet **312**, third eyelet **314**, and fourth eyelet **316** may be disposed on upper **102** between first eyelet **310** and fifth eyelet **318**. Generally, each of first eyelet **310**, second eyelet **312**, third eyelet **314**, fourth eyelet **316**, and fifth eyelet **318** may include a corresponding eyelet disposed in a similar location on lateral side **18** of upper **102** to form a pair of eyelets. In this embodiment, article **100** includes five eyelet pairs disposed on upper **102**. In other embodiments, article **100** may include fewer or greater pairs of eyelets. In other cases, eyelets may be arranged asymmetrically and/or not disposed together in pairs.

In some embodiments, portions other than medial side **16** and lateral side **18** of upper **102** associated with lacing area **108** may include provisions to receive lace **110**. In one embodiment, toe portion **114** may include one or more eyelets near lacing area **108** to anchor lace **110** in toe portion **114**. In other embodiments, tongue **112** may also include provisions to receive lace **110**. In one embodiment, tongue **112** may include one or more eyelets to secure tongue **112** in place when a foot is disposed within upper **102**.

In some embodiments, wrap member **150** may include an attachment system that corresponds to one or more portions of shoe fastening system **106**. In some embodiments, wrap member **150** may include a removable attachment system. In this embodiment, wrap member **150** includes a plurality of lacing holes that may be associated with lacing area **108** on upper **102**. The term “lacing hole” as used throughout this detailed description and in the claims refers to a portion of a wrap member that includes an opening to receive a lace. In some embodiments, a lacing hole may include an eyelet as described above. In this embodiment, wrap member **150** includes a first lacing hole **322**, a second lacing hole **324**, a third lacing hole **326**, and a fourth lacing hole **328** associated with medial side **16** of article **100**. Similarly, wrap member **150** may include a fifth lacing hole **332**, a sixth lacing hole

334, a seventh lacing hole 336, and an eighth lacing hole 338 associated with lateral side 18 of article 100.

In some embodiments, one or more lacing holes disposed on wrap member 150 may be associated with eyelets disposed in lacing area 108 on upper 102. In one exemplary embodiment, the plurality of lacing holes disposed on wrap member 150 may be spaced apart to be capable of substantially aligning with the plurality of eyelets on upper 102. In this embodiment, first lacing hole 322, second lacing hole 324, third lacing hole 326, and fourth lacing hole 328 are substantially aligned, respectively, with second eyelet 312, third eyelet 314, fourth eyelet 316, and fifth eyelet 318 on medial side 16 of upper 102. Similarly, fifth lacing hole 332, sixth lacing hole 334, seventh lacing hole 336, and eighth lacing hole 338 may be substantially aligned with corresponding eyelets disposed on lateral side 18 of upper 102.

Referring again to FIG. 3, article 100 is shown with lace 110 loosely threaded through the plurality of eyelets disposed in lacing area 108 on upper 102 and the plurality of lacing holes disposed on wrap member 150. With this arrangement, wrap member 150 may be removably attached to upper 102 using lace 110. In other embodiments, wrap member 150 may be detachable from upper 102 using other temporary attachment mechanisms.

Lace 110 may be threaded through the plurality of eyelets on upper 102 as well as the plurality of lacing holes on wrap member 150 in any manner known in the art. FIG. 3 illustrates an exemplary embodiment of a threading of lace 110 through eyelets on upper 102 as well as the plurality of lacing holes on wrap member 150. In other embodiments, lace 110 may be threaded in a different manner to removably attach upper 102 and wrap member 150 around a foot of a wearer.

In some embodiments, a foot may be inserted into entry hole 104 of article of footwear 100. Once a foot is inserted in article 100, lace 110 may be fastened to secure the foot within article 100. The fastening of lace 110 tightens upper 102 and wrap member 150 around the foot of the wearer. In some embodiments, wrap member 150 extends under a portion of the sole structure. In one embodiment, wrap member 150 may extend around a portion of midfoot region 12 of sole structure 101 that is substantially aligned with an arch of a foot of a wearer. With this arrangement, the fastening of lace 110 may cause wrap member 150 to exert tension on midfoot region 12 of article 100 and to provide support to an arch of a foot of a wearer.

In some embodiments, a wearer may adjust the amount that wrap member 150 is fastened around article 100. The fastening of wrap member 150 may be adjusted by modifying the tautness of the fastening of lace 110. With this arrangement, wrap member 150 may be adjusted to provide comfort and support to an arch of a foot of a wearer.

In some cases, modifying the fit of wrap member 150 around sole structure 101 allows for some customization of the width of article 100. With this arrangement, a wearer may adjust the fastening of lace 110 to achieve different widths for upper 102 of article 100. In other cases, wrap member 150 may be provided with different lengths to adjust the tightness and/or fit of wrap member 150 around article 100. With this arrangement, one or more wrap members of various lengths may be provided for use with article 100 to allow a wearer to achieve a customized fit around an arch of a foot.

Referring now to FIG. 4, in this embodiment, lace 110 has been removed so that wrap member 150 may be detached from upper 102. In some embodiments, upper 102 may include a saddle portion 400. In this embodiment, saddle portion 400 corresponds to the portion of upper 102 that is under wrap member 150 when wrap member 150 is attached

to article 100. It should be understood that while medial side 16 of article 100 is illustrated in FIG. 4 and described in the embodiments below, corresponding elements also may be provided on lateral side 18 of article 100.

In some embodiments, saddle portion 400 may include one or more provisions for providing ventilation between upper 102 and wrap member 150. In one exemplary embodiment, saddle portion 400 may include a plurality of ventilation members 402 disposed over the surface. In some cases, ventilation members 402 may be small holes or perforations in the surface of upper 102 that allow air to move between the interior of article 100 and outside. In other cases, ventilation members 402 may be shallow indentations or pits in the surface of upper 402 that allow air to move between wrap member 150 and upper 102. In other embodiments, ventilation members 402 may be optional, and omitted.

In some embodiments, ventilation members 402 may be disposed over the saddle portion 400 in a pattern. In some embodiments, the pattern of ventilation members 402 may be designed to provide desired amounts of ventilation to saddle portion 400 of upper 102. In one exemplary embodiment, ventilation members 402 may be arranged in a checkerboard pattern. In other embodiments, ventilation members 402 may be arranged in any geometric, regular, or irregular pattern.

In some embodiments, saddle portion 400 of upper 102 may be bounded on one or more side by alignment strips. In an exemplary embodiment, a forward alignment strip 404 is disposed generally on upper 102 in a location towards forefoot region 10 of article 100 and a rearward alignment strip 406 is disposed generally on upper 102 in a location towards heel region 14 of article 100. Forward alignment strip 404 extends from the bottom of upper 102 adjacent to midsole 202 to the top of upper 102 adjacent to lacing area 108. Similarly, rearward alignment strip 406 may extend from the bottom of upper 102 adjacent to midsole 202 to the top of upper 102 adjacent to lacing area 108. In this embodiment, rearward alignment strip 406 may terminate at lacing area 108 between first eyelet 310 and second eyelet 312. In other embodiments, forward alignment strip 404 and/or rearward alignment strip 406 may begin or terminate along different portions of upper 102.

In this embodiment, forward alignment strip 404 and rearward alignment strip 406 may form a pair of alignment strips that bound the area of upper 102 corresponding to saddle portion 400. In some embodiments, forward alignment strip 404 and rearward alignment strip 406 may be spaced apart on upper 102 so as to substantially correspond to the shape of wrap member 150. In this embodiment, wrap member 150 substantially fits into the space between the pair of alignment strips when wrap member 150 is attached to article 100.

In one exemplary embodiment, forward alignment strip 404 and rearward alignment strip 406 may be constructed of a material that has a thickness that is substantially similar to the thickness of wrap member 150. With this arrangement, wrap member 150 may sit flush over saddle portion 400 between the pair of alignment strips on upper 102. In other embodiments, forward alignment strip 404 and/or rearward alignment strip 406 may be more or less thick than wrap member 150.

Forward alignment strip 404 and rearward alignment strip 406 may be attached to upper 102 using any suitable attachment mechanism, including, but not limited to: stitching, adhesive bonding, and/or heat bonding. In some cases, alignment strips may be constructed from any material used to construct upper 102. In other cases, alignment strips may be constructed from different materials as those used to con-

struct upper **102**, including materials that have different characteristics, including, but not limited to: color, reflectivity, and/or roughness.

Referring now to FIG. 5, wrap member **150** is illustrated completely detached from article **100**. In some embodiments, article **100** may include a channel **500** allowing wrap member **150** to extend under sole structure **101**. In an exemplary embodiment, channel **500** may be disposed in midsole **200** of sole structure **101**. In this embodiment, channel **500** is located generally in midfoot region **12** of sole structure **101**. In some cases, channel **500** may be located so as to be substantially aligned with an arch of a foot of a wearer of the article of footwear **100**.

In some embodiments, forward alignment strip **404** and rearward alignment strip **406** may assist to guide wrap member **150** along an angle extending under sole structure **101**. In an exemplary embodiment, wrap member **150** may extend under a portion of sole structure **101** through channel **500** at a first angle **A1**. In one embodiment, first angle **A1** may be associated with an alignment of the plurality of lacing holes disposed on wrap member **150**. In this embodiment, first lacing hole **322**, second lacing hole **324**, third lacing hole **326**, and fourth lacing hole **328** are substantially aligned, respectively, with second eyelet **312**, third eyelet **314**, fourth eyelet **316**, and fifth eyelet **318** on medial side **16** of upper **102** to form first angle **A1** of wrap member **150** as it extends under sole structure **101** through channel **500**.

In some embodiments, wrap member **150** may include a first edge **502** located at a first longitudinal end and a second edge **504** located at a second longitudinal end. First edge **502** and second edge **504** are disposed on opposite ends of wrap member **150** along the longitudinal axis. In this embodiment, first lacing hole **322**, second lacing hole **324**, third lacing hole **326**, and fourth lacing hole **328** may be disposed adjacent to first edge **502** on first longitudinal end of wrap member **150**. Similarly, fifth lacing hole **332**, sixth lacing hole **334**, seventh lacing hole **336**, and eighth lacing hole **338** may be disposed adjacent to second edge **504** on second longitudinal end of wrap member **150**.

Wrap member **150** also may include a midsection portion **506** disposed generally between first edge **502** and second edge **504**. In this embodiment, midsection portion **506** may extend under sole structure **101** when wrap member **150** is attached to article **100**. With this arrangement, midsection portion **506** may provide support to an arch of a foot of a wearer when wrap member **150** is fastened around article **100**. With this arrangement, tightening lace **110** may exert tension on wrap member **150** within channel **500** and provide support to an arch of a foot of a wearer.

In some embodiments, wrap member **150** may taper from a first width **W1** associated with first edge **502** and/or second edge **504** to a second width **W2** associated with midsection portion **506**. In one embodiment, first width is larger than second width **W2**. In other embodiments, first width **W1** and second width **W2** may be substantially similar. In still other embodiments, second width **W2** may be larger than first width **W1**.

In an exemplary embodiment, first width **W1** may be sized and dimensioned so as to substantially correspond to a first length **L1** associated with a portion of lacing area **108**. In some embodiments, first length **L1** associated with a portion of lacing area **108** may correspond to one or more of the plurality of eyelets in upper **102**. In one embodiment, first length **L1** corresponds to the spacing on upper **102** associated with second eyelet **312**, third eyelet **314**, fourth eyelet **316**, and fifth eyelet **318**.

In an exemplary embodiment, second width **W2** may be sized and dimensioned so as to substantially correspond to a second length **L2** associated with channel **500**. In some embodiments, second length **L2** associated with channel **500** may correspond to a portion of a foot of a wearer of the article of footwear **100**. In one exemplary embodiment, second length **L2** may be associated with an arch of a foot of a wearer of the article of footwear **100**. In other embodiments, second width **W2** may be larger or smaller to provide different amounts of support to article **100** at midfoot region **12**.

FIG. 6 illustrates an exploded view of underside of article **100** showing sole structure **101** with wrap member **150** removed. In this embodiment, sole structure **101** includes midsole **200** and outsole **202**. In some embodiments, outsole **202** may include one or more portions disposed in forefoot region **10**, midfoot region **12**, and/or heel region **14** of article **100**. In an exemplary embodiment, outsole **202** may include a forefoot outsole portion **600** associated generally with forefoot region **10** of sole structure **101**. Outsole **202** also may include a heel outsole portion **606** associated generally with heel region **14** of sole structure **101**. In this embodiment, outsole **202** is not continuous through midfoot region **12** between forefoot outsole portion **600** in forefoot region **10** and heel outsole portion **606** in heel region **14**. In other embodiments, outsole **202** may extend into a portion of midfoot region **12**.

In some embodiments, sole structure **101** may include midsole **200** extending through each of forefoot region **10**, midfoot region **12**, and/or heel region **14** between medial side **16** and lateral side **18** of article **100**. In one embodiment, sole structure **101** includes a portion of midsole **200** disposed generally in midfoot region **12** that is exposed between outsole **202** in forefoot region **10** and heel region **14**. In an exemplary embodiment, midsole **200** may include channel **500** disposed at a location between forefoot outsole portion **600** and heel outsole portion **606**. In some cases, channel **500** may be formed by an engineered midsole **200** incorporating channel **500**. In other cases, channel **500** may be formed by removing material from midsole **200**, including, but not limited to using lasers to remove the material.

In an exemplary embodiment, channel **500** may include a groove **602** formed in midsole **200** at midfoot region **12** of sole structure **101**. In some embodiments, groove **602** may be shaped so as to substantially correspond to the shape of wrap member **150**. In this embodiment, wrap member **150** substantially fits into groove **602** in midsole **200** between outsole **202** when wrap member **150** is attached to article **100**. Groove **602** may have a size corresponding to second length **L2**. In one embodiment, second length **L2** may be sized and dimensioned so as to substantially correspond to second width **W2** of midsection portion **506** of wrap member **150**.

In one exemplary embodiment, groove **602** may have depth **604** that is substantially similar to the thickness of wrap member **150** at midsection portion **506**. With this arrangement, wrap member **150** may sit flush under article **100** in groove **602** in midsole **200**. In other embodiments, depth **604** of groove **602** may be more or less thick than wrap member **150**.

In some embodiments, wrap member **150** may be configured to be symmetric along one or more axes. In one embodiment, wrap member **150** may be configured to be substantially symmetric along the lateral axis. With this arrangement, first edge **502** and second edge **504** may generally align when wrap member **150** is folded in half. In other embodiments, wrap member **150** may be configured to be asymmetric along one or more axes. In one embodiment, wrap member **150** may be configured to be asymmetric along the longitudinal axis. In

an exemplary embodiment, wrap member 150 may include a leading edge 508 and a trailing edge 510. In this embodiment, leading edge 508 may have a generally convex shape. In some cases, trailing edge 510 may have a generally dissimilar shape as leading edge 508. In other cases, leading edge 508 and trailing edge 510 may have a substantially similar shape. In other embodiments, leading edge 508 and/or trailing edge 510 may have other shapes.

In some embodiments, wrap member 150 may include one or more regions. In this embodiment, wrap member 150 may include a first region 620 associated with first edge 502, a second region 622 associated with second edge 504, and a third region 624 associated with midsection portion 506. It should be understood that first region 620, second region 622, and third region 624 are only intended for purposes of description and are not intended to demarcate precise regions of wrap member 150, but rather, to describe relative positions.

In some embodiments, one or more regions of wrap member 150 may be associated with a shape along one of leading edge 508 and trailing edge 510. In an exemplary embodiment, leading edge 508 of each of first region 620, second region 622, and third region 624 may be associated with a substantially similar shape. In one embodiment, leading edge 508 of each of first region 620, second region 622, and third region 624 may be associated with a generally concave shape. In some cases, leading edge 508 of one or more of first region 620, second region 622, and third region 624 may be more or less concave. In one embodiment, leading edge 508 of first region 620 and second region 622 may be concave to a greater degree than leading edge 508 of third region 624.

In some embodiments, trailing edge 510 of each of first region 620, second region 622, and third region 624 may be associated with different shape. In one embodiment, trailing edge 510 of first region 620 and second region 622 may be associated with a first shape and trailing edge 510 of third region 624 may be associated with a second shape. In an exemplary embodiment, trailing edge 510 of first region 620 and second region 622 may be associated with a generally convex shape. In this embodiment, trailing edge 510 of third region 624 may be associated with a generally concave shape. With this arrangement, first region 620 and second region 622 may have a similar shape on leading edge 508 and trailing edge 510. Whereas, third region 624 may have a dissimilar shape on leading edge 508 and trailing edge 510. In other embodiments, leading edge 508 and/or trailing edge 510 of each of first region 620, second region 622, and third region 624 may have other shapes.

In some embodiments, the shape of one or more regions of wrap member 150 may be adapted to correspond to a portion of article 100. In one embodiment, the shape of wrap member 150 may correspond to one or more portions of channel 500 in sole structure 101. In an exemplary embodiment, the shape of leading edge 508 and trailing edge 510 of third region 624 of wrap member 150 may be adapted to correspond to groove 602 in midsole 200. In this embodiment, the forward edge of groove 602 in a direction of forefoot region 10 may have a substantially similar shape as leading edge 508 of third region 624 of wrap member 150. Similarly, the rearward edge of groove 602 in a direction of heel region 14 may have a substantially similar shape as trailing edge 510 of third region 624 of wrap member 150. In other embodiments, one or more portions of sole structure 101, including midsole 200, may have a substantially similar shape as one or more regions of wrap member 150.

In other embodiments, leading edge 508 and trailing edge 510 of first region 620 and/or second region 622 may have a shape corresponding to one or more alignment strips disposed

on upper 102. In one embodiment, leading edge 508 and trailing edge 510 of first region 620 may have a shape that substantially corresponds to the shape of forward alignment strip 404 and rearward alignment strip 406, respectively, on upper 102. In some embodiments, leading edge 508 and trailing edge 510 of first region 620 and/or second region 622 may have a substantially similar shape as saddle portion 400 on upper 102.

In some embodiments, sole structure 101 may include further include cleat members that can enhance traction with the ground. In some cases, sole structure 101 may include cleat members that are incorporated into outsole 202. In other cases, outsole 202 may include removable cleat members. In some embodiments, sole structure 101 and/or outsole 202 may include one or more features described in U.S. Pat. No. 6,817,117 to Campbell, the entirety of which is incorporated by reference. In one embodiment, the traction elements described in U.S. Pat. No. 6,817,117 are used in combination with article 100.

Referring now to FIG. 7, an exemplary embodiment of a reversible wrap member is shown. For the purposes of illustration, an article of footwear 700 for a right foot is shown. In this embodiment, article 700 includes a reversible wrap member 702. Wrap member 702 may be substantially similar to wrap member 150 described in one or more of the embodiments above.

In some embodiments, wrap member 702 may be reversible on article of footwear 700. In other words, wrap member 702 may be arranged with either side of wrap member 702 facing towards article 700. In one embodiment, wrap member 702 may be flipped over from a first configuration with one side facing towards article 700 to a second configuration with the opposite side facing towards article 700. In some cases, wrap member 702 may be reversible on the same article of footwear. In other cases, wrap member 702 may be reversible on either or both articles of footwear associated with a pair of footwear.

In some embodiments, wrap member 702 may be made reversible by configuring wrap member 702 to be substantially symmetric along the lateral axis. In one embodiment, wrap member 702 may be made reversible such that opposing edges on the distal ends of wrap member 702 may generally align when wrap member 702 is folded in half. In some embodiments, one or more regions of wrap member 702 may be associated with a shape along one of a leading edge and a trailing edge. In an exemplary embodiment, the leading edges and/or trailing edges associated with opposite ends of wrap member 702 may be associated with a substantially similar shape. With this arrangement, wrap member 702 may retain a substantially similar fit with article 700 when in the first configuration and the second configuration.

In some embodiments, wrap member 702 may include a first surface 704 disposed on one side and a second surface 706 disposed on the opposite side. In some embodiments, wrap member 702 may be reversible between sides such that wrap member 702 may have first surface 704 or second surface 706 disposed facing towards article 700. In an exemplary embodiment, first surface 704 and second surface 706 may have different characteristics. In this embodiment, first surface 704 and second surface 706 may be different colors. In other embodiments, portions of wrap member 702, including one or more surfaces, may have various different characteristics, including, but not limited to: color, text, printed design, reflectivity, roughness, and/or material.

As shown in FIG. 7, reversible wrap member 702 may be changed from a first configuration with second surface 706 disposed on the outside of article 700 to a second configura-

tion with first surface **704** disposed on the outside of article **700**. In this embodiment, reversible wrap member **702** may be changed between the first configuration and the second configuration by turning over reversible wrap member **702**. With this arrangement, article **700** may be changed in appearance based on the different characteristic associated with each of first surface **704** and second surface **706**. In this exemplary embodiment, the different characteristic between first surface **704** and second surface **706** is color. In one embodiment, a first color associated with first surface **704** may be substantially identical to a color associated with an upper of article **700** and a second color associated with second surface **706** may be a contrasting color. With this arrangement, article **700** may be changeable between a uniform color and a saddle shoe appearance.

Other configurations may be provided for article **700** using reversible wrap members with various different characteristics, including, but not limited to: color, text, printed design, reflectivity, roughness, and/or material.

Referring now to FIG. **8**, an exemplary embodiment of an interchangeable wrap member is shown. In this embodiment, a pair of footwear is shown, including right article **800** and left article **801**. In some embodiments, the pair of footwear may include one or more interchangeable wrap members. In this embodiment, for the purposes of illustration a single interchangeable wrap member **802** is shown. Wrap member **802** may be substantially similar to wrap member **150** and/or reversible wrap member **702** described in one or more of the embodiments above.

In some embodiments, wrap member **802** may be interchangeable between right article **800** and left article **801**. In other words, wrap member **802** may be configured to fit on both right article **800** and left article **801**. As shown in FIG. **8**, interchangeable wrap member **802** may be removed from right article **800** and attached to left article **801**. In this embodiment, interchangeable wrap member **802** may fit both right article **800** and left article **801**.

In one embodiment, wrap member **802** may be flipped over from a first configuration with one side facing towards right article **800** to a second configuration with the opposite side facing towards left article **801**. In some embodiments, interchangeable wrap member **802** also may be reversible on the same article of footwear as described above in reference to FIG. **7**.

In some embodiments, wrap member **802** may be made interchangeable between right article **800** and left article **801** by configuring wrap member **802** to be substantially symmetric along the lateral axis. In one embodiment, wrap member **802** may be made interchangeable such that opposing edges on the distal ends of wrap member **802** may generally align when wrap member **802** is folded in half. In some embodiments, one or more regions of wrap member **802** may be associated with a shape along one of a leading edge and a trailing edge. In an exemplary embodiment, the leading edges and/or trailing edges associated with opposite ends of wrap member **802** may be associated with a substantially similar shape. With this arrangement, wrap member **802** may retain a substantially similar fit with right article **800** and left article **801**.

In some embodiments, wrap member **802** may include a first surface **804** disposed on one side and a second surface **806** disposed on the opposite side. In one exemplary embodiment, first surface **804** and second surface **806** may have different characteristics. In this embodiment, first surface **804** and second surface **806** may be different colors. In other embodiments, portions of interchangeable wrap member **802**, including one or more surfaces, may have various dif-

ferent characteristics, including, but not limited to: color, text, printed design, reflectivity, roughness, and/or material.

In other embodiments, additional wrap members may be supplied with and/or purchased separate from article **100**. In some embodiments, additional wrap members may be provided with different characteristics. With this arrangement, the appearance of an article of footwear may be changed by a wearer by changing the wrap member.

While various embodiments of the invention have been described, the description is intended to be exemplary, rather than limiting and it will be apparent to those of ordinary skill in the art that many more embodiments and implementations are possible that are within the scope of the invention. Accordingly, the invention is not to be restricted except in light of the attached claims and their equivalents. Also, various modifications and changes may be made within the scope of the attached claims.

What is claimed is:

1. A wrap member in combination with an article of footwear, comprising:
 - an upper and a sole structure;
 - the upper further including a plurality of ventilation holes disposed through a region of the upper extending from a lacing area of the upper to a lower area of the upper, the lower area being closer to the sole structure than the lacing area;
 - the wrap member comprising:
 - a first surface on one side of the wrap member;
 - a second surface on an opposing side from the first surface of the wrap member;
 - a first edge disposed at a first longitudinal end of the wrap member;
 - a second edge disposed at a second longitudinal end of the wrap member;
 - a midsection portion disposed generally between the first edge and the second edge;
 - wherein the wrap member is substantially symmetric along its lateral axis so that the first edge and the second edge generally align when the wrap member is folded in half;
 - wherein the wrap member is removably attached to the article of footwear such that the wrap member is in contact with the upper and the wrap member is in contact with a portion of the sole structure;
 - wherein the plurality of ventilation holes are covered when the wrap member is attached to the article of footwear and wherein the plurality of ventilation holes are exposed when the wrap member is unattached to the article of footwear;
 - wherein the wrap member is reversible between a first configuration and a second configuration, wherein the first surface of the wrap member is in contact with the article of footwear in the first configuration and wherein the second surface of the wrap member is in contact with the article of footwear in the second configuration; and
 - wherein the upper includes a first alignment strip on a side of the upper and wherein the upper includes a second alignment strip on the side of the upper, wherein the first alignment strip and the second alignment strip are physically spaced apart on the upper so as to substantially correspond to a longitudinal shape of the wrap member, and wherein the plurality of ventilation holes are disposed through the region of the upper extending between the first alignment strip and the second alignment strip.
2. The wrap member and the article of footwear according to claim **1**, wherein the article of footwear fits a left foot and wherein the wrap member is configured to be used inter-

15

changeably with the article of footwear and another article of footwear configured to fit a right foot.

3. The wrap member and the article of footwear according to claim 1, wherein the first surface and the second surface have at least one different characteristic.

4. The wrap member and the article of footwear according to claim 3, wherein the at least one different characteristic comprises at least one of: color, text, printed design, reflectivity, roughness, and material.

5. The wrap member and the article of footwear according to claim 1, wherein the plurality of ventilation holes are configured in a regular pattern, wherein the regular pattern extends between the first alignment strip and the second alignment strip and wherein the regular pattern extends between the lacing area and the lower portion of the upper on the side.

6. The wrap member and the article of footwear according to claim 1, wherein the upper includes at least one eyelet and wherein each ventilation hole in the plurality of ventilation holes is smaller than the at least one eyelet.

7. A wrap member in combination with an article of footwear, comprising:

an upper and a sole structure, the sole structure further including a midsole and an outsole;

wherein the midsole includes a groove that is exposed on an underside of the article of footwear;

the wrap member comprising:

a first surface on one side of the wrap member;

a second surface on an opposing side from the first surface of the wrap member;

a first edge disposed at a first longitudinal end of the wrap member, a second edge disposed at a second longitudinal end of the wrap member, and a midsection portion disposed generally between the first edge and the second edge;

wherein the first edge and the second edge each include a plurality of lacing holes that are spaced apart to be capable of substantially aligning with a plurality of eyelets in the lacing area of the upper of the article of footwear and wherein the wrap member can be removably attached to the upper by inserting a lace of the article of footwear through the plurality of eyelets in the upper and by inserting the lace through the plurality of lacing holes on the wrap member;

wherein the wrap member is reversible between a first configuration and a second configuration;

wherein in the first configuration the wrap member is attached to the article of footwear such that:

the first surface of the wrap member is in contact with the upper;

the midsection portion of the wrap member extends through the groove in the midsole with the first surface of the wrap member in contact with the midsole;

wherein in the second configuration the wrap member is attached to the article of footwear such that:

the second surface of the wrap is in contact with the upper; and

the midsection portion of the wrap member extends through the groove in the midsole with the second surface of the wrap member in contact with the midsole.

8. The wrap member and the article of footwear according to claim 7, wherein tightening the lace disposed through the plurality of eyelets and the plurality of lacing holes produces tension at the midsection portion on the wrap member across the sole structure.

9. The wrap member and the article of footwear according to claim 7, wherein the groove is located in an arch portion of

16

the sole structure so that when the midsection portion of the wrap member is disposed in the groove the midsection portion provides support to the arch portion of the sole structure.

10. The wrap member and the article of footwear according to claim 7, wherein the wrap member tapers from a first width associated with each of the first edge and the second edge to a second width associated with the midsection portion.

11. The wrap member and the article of footwear according to claim 10, wherein the first width is sized and dimensioned so as to substantially correspond to a first length associated with the lacing area.

12. The wrap member and the article of footwear according to claim 11, wherein the second width is sized and dimensioned so as to substantially correspond to a second length associated with the portion of the sole structure.

13. The wrap member and the article of footwear according to claim 7, wherein the groove has a shape corresponding to a shape of the midsection portion of the wrap member.

14. The wrap member and the article of footwear according to claim 7, wherein the groove has a length between a forward edge and a rearward edge of the channel and wherein the midsection portion has a width between a leading edge and a trailing edge of the wrap member, and wherein the length of the groove is substantially equal to the width of the midsection portion.

15. A reversible wrap member in combination with an article of footwear, comprising:

an upper and a sole structure, the sole structure further including a midsole and an outsole;

the upper further including a first alignment strip and a second alignment strip on a lateral side of the upper and the upper including a third alignment strip and a fourth alignment strip on a medial side of the upper;

wherein the midsole includes a groove that is exposed on an underside of the article of footwear;

the wrap member comprising:

a first surface on one side of the wrap member;

a second surface on an opposing side from the first surface of the wrap member;

a first edge disposed at a first longitudinal end of the wrap member;

a second edge disposed at a second longitudinal end of the wrap member;

a leading edge extending from the first edge to the second edge and a trailing edge extending from the first edge to the second edge, the leading edge being disposed closer to a forefoot of the article of footwear than the trailing edge when the wrap member is attached to the article of footwear;

a midsection portion disposed generally between the first edge and the second edge;

wherein the wrap member is substantially symmetric along its lateral axis so that the first edge and the second edge generally align when the wrap member is folded in half;

wherein the wrap member is reversible between a first configuration and a second configuration, wherein the first surface of the wrap member is in contact with the article of footwear in the first configuration and wherein the second surface of the wrap member is in contact with the article of footwear in the second configuration;

wherein a shape of the leading edge of the wrap member corresponds to a shape of the first alignment strip, a shape of a forward edge of the groove and a shape of the third alignment strip in the first configuration and wherein the shape of the leading edge of the wrap member corresponds to the shape of the first alignment strip,

the shape of the forward edge of the groove and the shape of the third alignment strip in the second configuration; and

wherein a shape of the trailing edge of the wrap member corresponds to a shape of the second alignment strip, a shape of a rearward edge of the groove and a shape of the fourth alignment strip in the first configuration and wherein the shape of the trailing edge of the wrap member corresponds to the shape of the second alignment strip, the shape of the rearward edge of the groove and the shape of the fourth alignment strip in the second configuration.

16. The wrap member and the article of footwear according to claim 15, wherein the midsection portion of the wrap member is flush with the midsole when the midsection portion is disposed within the groove.

17. The wrap member and the article of footwear according to claim 15, wherein the leading edge is contoured and the trailing edge is contoured.

18. The wrap member and the article of footwear according to claim 15, wherein at least one portion of the trailing edge has a generally convex shape.

19. The wrap member and the article of footwear according to claim 15, wherein the leading edge has a generally concave shape.

* * * * *