



US 20130172093A1

(19) **United States**

(12) **Patent Application Publication**

**Leech**

(10) **Pub. No.: US 2013/0172093 A1**

(43) **Pub. Date: Jul. 4, 2013**

(54) **SYSTEM FOR TRACKING A GOLF BALL AND DISPLAYING AN ENHANCED IMAGE OF THE GOLF BALL**

(75) Inventor: **Nicholas A. Leech**, Aloha, OR (US)

(73) Assignee: **NIKE, INC.**, Beaverton, OR (US)

(21) Appl. No.: **13/341,442**

(22) Filed: **Dec. 30, 2011**

**Publication Classification**

(51) **Int. Cl.**  
**A63B 57/00** (2006.01)

(52) **U.S. Cl.**  
USPC ..... **473/152; 473/409**

(57) **ABSTRACT**

A system for tracking a golf ball and displaying an enhanced image of the golf ball is disclosed. The system may display an enhanced image of the golf ball on a display such that the enhanced image is imposed upon a user's real world view. Displaying an enhanced image of the golf ball may help a user view the trajectory of the golf ball and find the golf ball after the golf ball lands. The system may display an enhanced image of the golf ball on a heads-up display configured to be worn on a person's head such that the user may view the enhanced image while remaining hands-free. The enhanced image may enable a user to compare the golf ball's trajectory with an ideal trajectory. The system may display other information, such as launch and flight information about the ball, on the heads-up display.

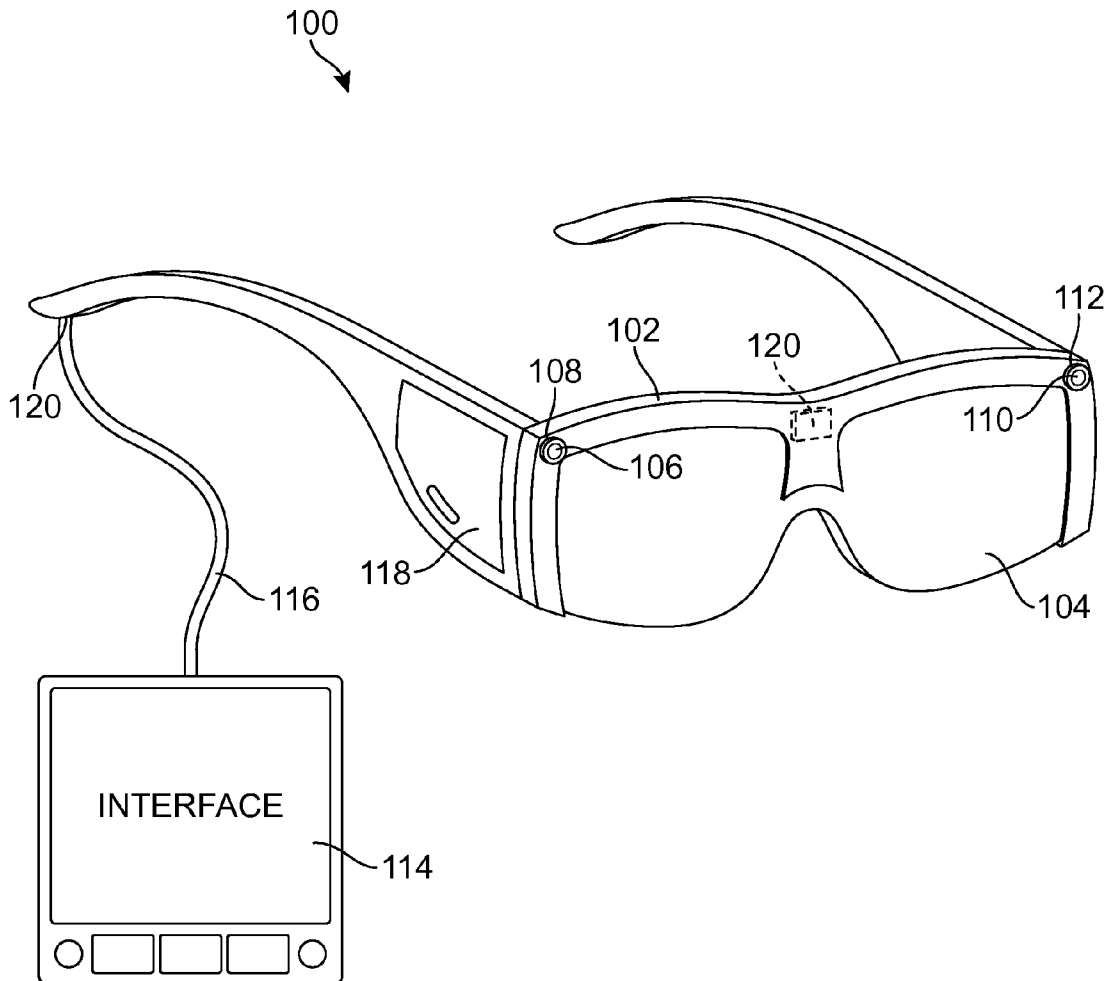

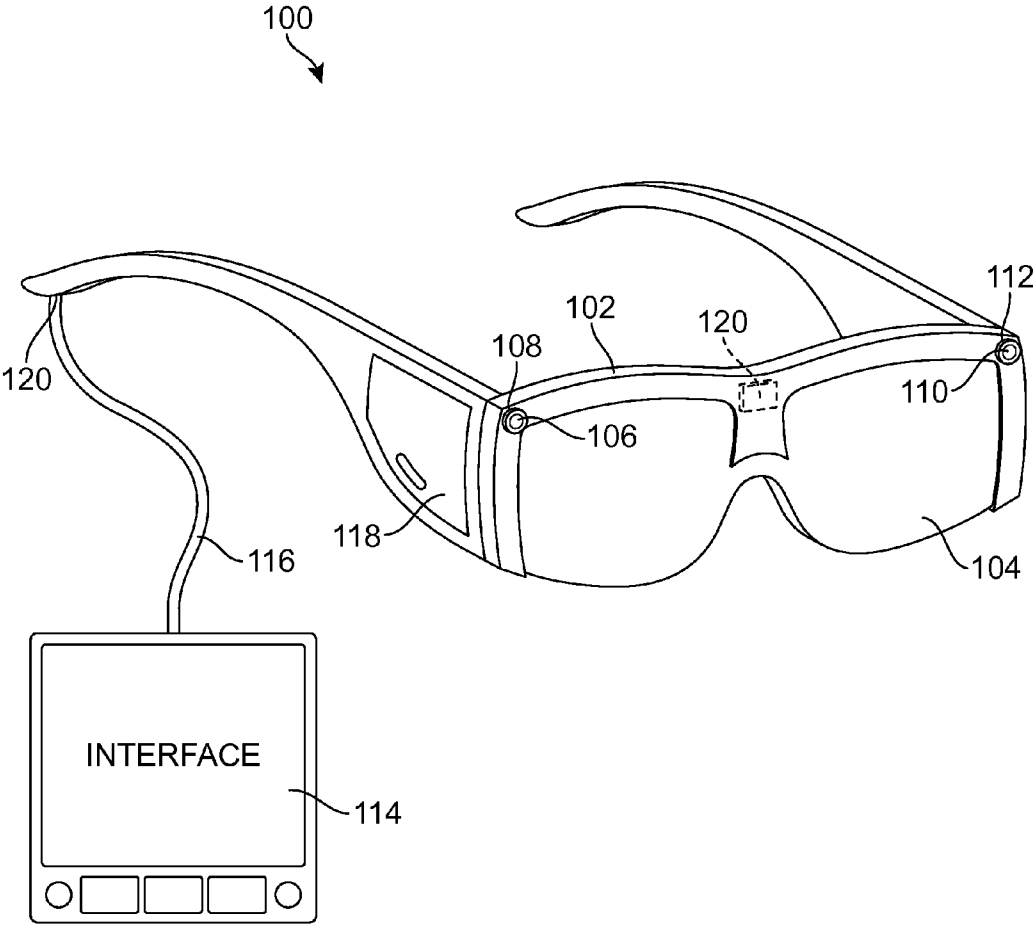

FIG. 1

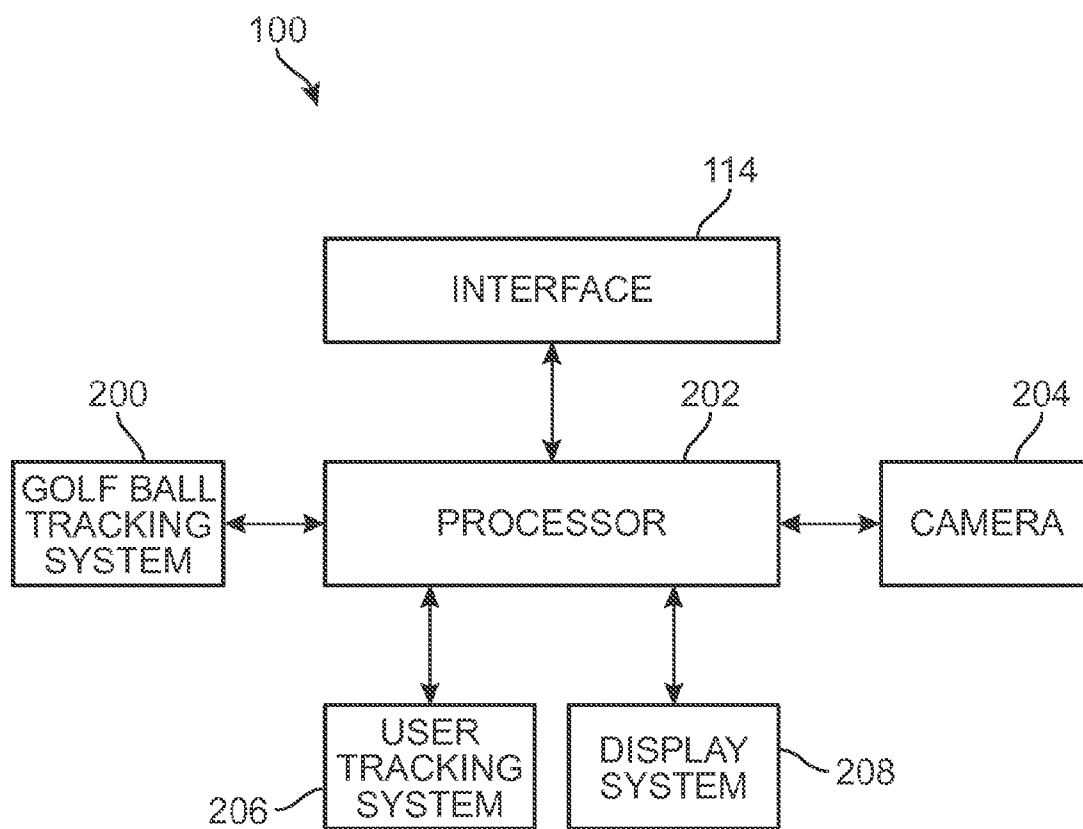
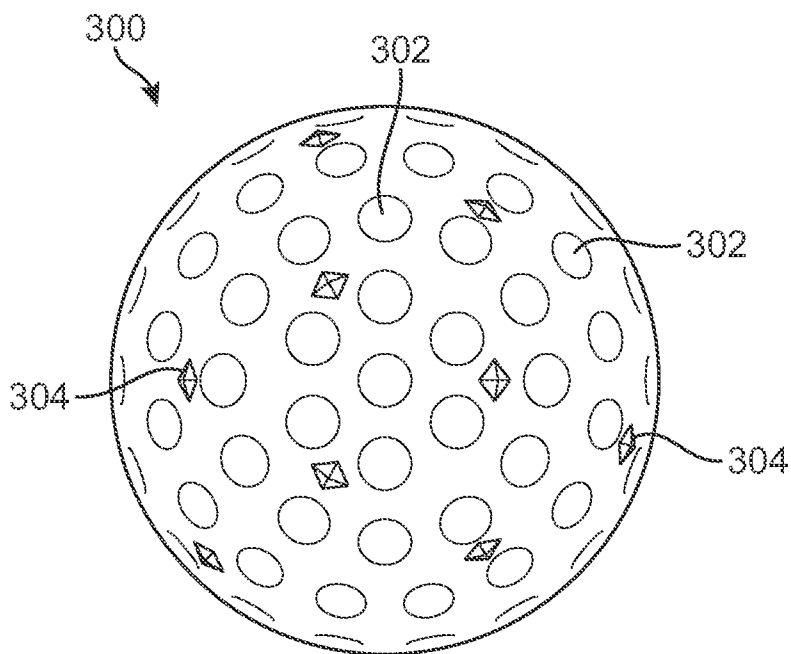
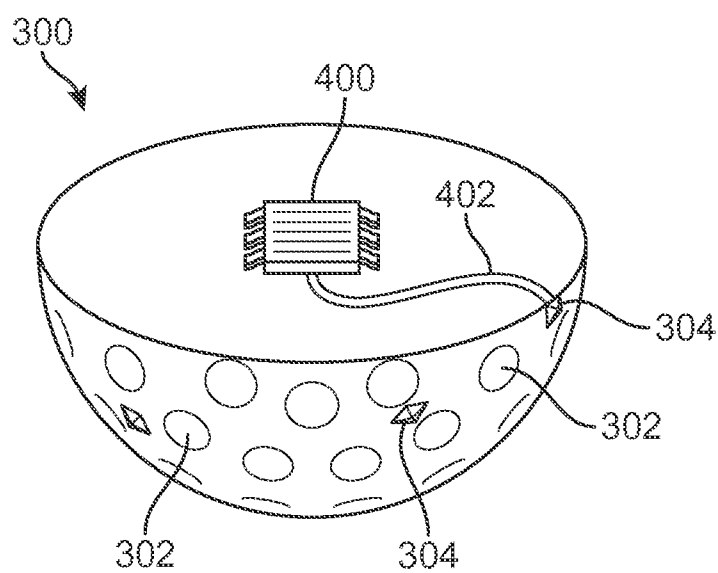

FIG. 2



**FIG. 3**



**FIG. 4**

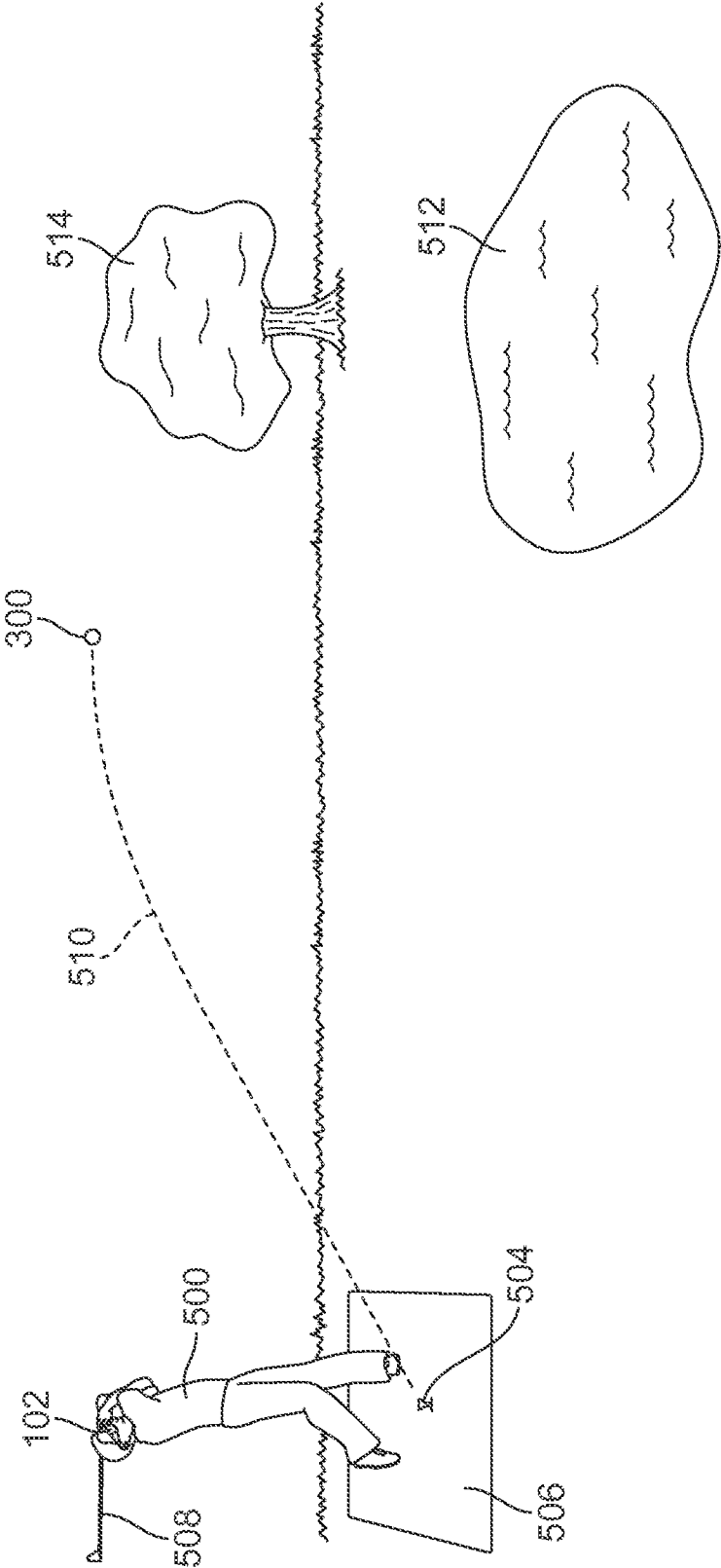

FIG. 5

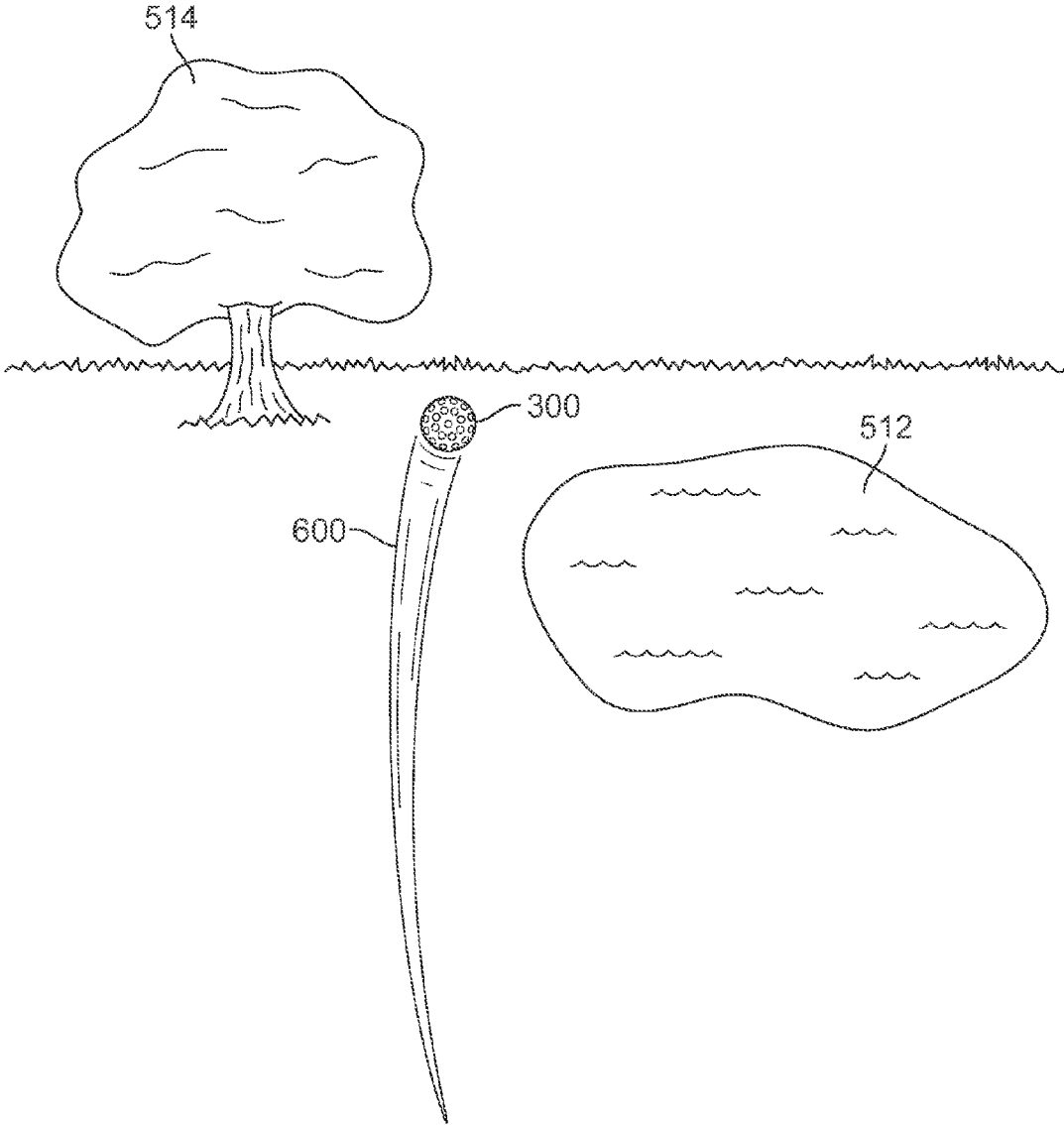

FIG. 6

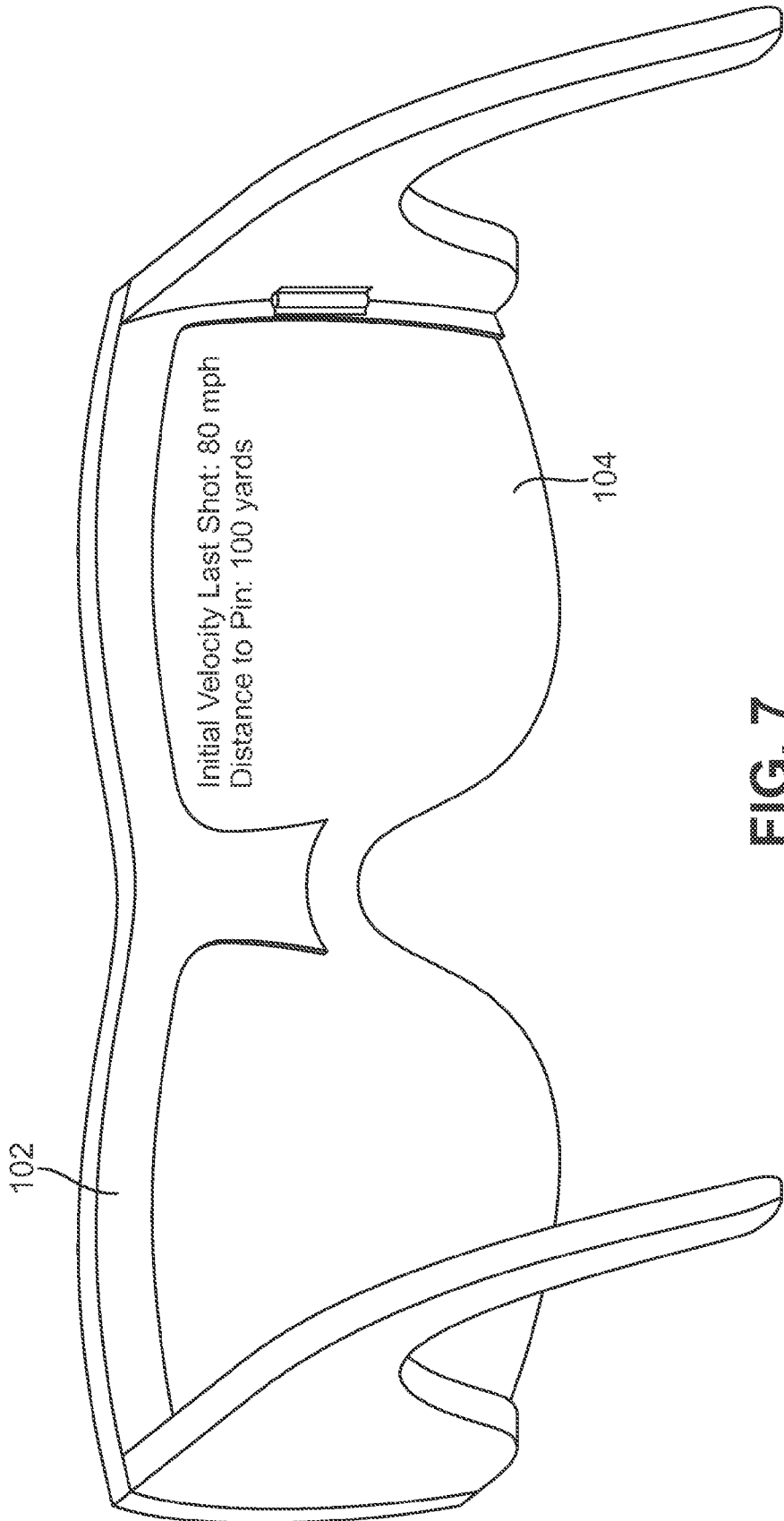

FIG. 7

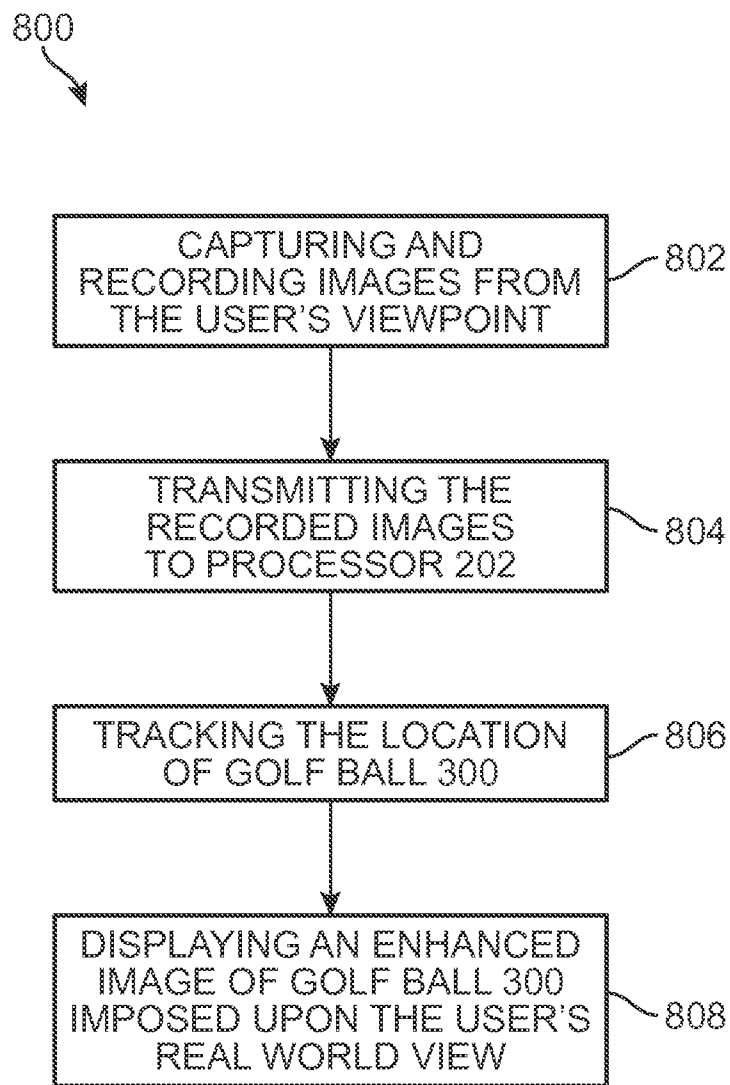

FIG. 8



**SYSTEM FOR TRACKING A GOLF BALL AND DISPLAYING AN ENHANCED IMAGE OF THE GOLF BALL**

**BACKGROUND**

**[0001]** The present invention relates generally to a system for tracking a golf ball and displaying an enhanced image of the golf ball.

**[0002]** The game of golf is an increasingly popular sport at both amateur and professional levels. Both amateur and professional golfers spend sizeable amounts of time developing the muscle memory and fine motor skills necessary to improve their game. Golfers try to improve their game by analyzing launch and trajectory information while playing golf. Golf balls are difficult to see when flying through the air on a golf course. Consequently, it is difficult to track the trajectory of golf balls and to find golf balls after they have landed. Thus, it would be advantageous to make a system for tracking a golf ball.

**SUMMARY**

**[0003]** In one aspect the disclosure provides a system for tracking a golf ball and displaying an image. The system may include a golf ball tracking system for tracking the location of a golf ball. The system may include a display device associated with the golf ball tracking system. The display device may be configured to be worn on a user's head and may include a display system configured to use the tracked location of the golf ball to display an enhanced image of the golf ball imposed upon the user's real world view. The golf ball tracking system may include a golf ball having a signal emitter. A signal receiver may be disposed on the display device and configured to receive a signal emitted by the signal emitter. The signal receiver may be coupled to the processor. The system may include a user interface. The display device may include one of eyeglasses, a helmet, and a visor. The system may include a display system associated with the display device. The display system may be configured to display enhanced images imposed upon the user's real world view. The enhanced images may be transparent.

**[0004]** In one aspect the disclosure provides a system for tracking a golf ball and displaying an image. The system may include a display device configured to be worn on a person's head. The system may include a camera associated with the display device. The camera may be configured to capture and record images of the user's real world view. The system may include a golf ball tracking system for tracking the location of a golf ball. The system may include at least one processor for controlling at least one of the camera, the golf ball tracking system, and the display system. The display device may include a display system configured to display an enhanced image of a golf ball captured by the camera imposed upon the user's real world view. The display device may include one of eyeglasses, a helmet, and a visor. The system may include a display system disposed adjacent a lens of the display device. The display system may be configured to display enhanced images imposed upon the user's real world view. The golf ball tracking system may include a golf ball sensor configured to detect a golf ball. The processor may be configured to process information provided by the golf ball sensor to determine the location of the golf ball. The system may include a golf ball having a signal emitter. The golf ball sensor may be configured to detect the golf ball by detecting signals emitted from

the signal emitter. The system may include a user tracking system configured to track the location of the user. The user tracking system may be disposed on the display device. The processor may be configured to use information relayed by the user tracking system to determine the distance between the user and a landmark.

**[0005]** In one aspect the disclosure provides a method of tracking a golf ball and displaying an image. The method may include capturing and recording images from a user's viewpoint. The method may include transmitting the recorded images to a processor. The method may include tracking the location of a golf ball disposed within a viewer's line of sight. The method may include displaying an enhanced image of the golf ball imposed upon the user's real world view. The enhanced image may be displayed on a display device configured to be worn on a user's head. The enhanced image of the golf ball may include a comet tail disposed over at least a portion of the golf ball's trajectory. The enhanced image of the golf ball may include an image of the golf ball in which the golf ball has been brightened and/or enlarged. The method may include displaying launch information of the golf ball on the display device. Tracking the location of the golf ball may include emitting a signal from a signal emitter disposed within the golf ball and processing the signal to determine the location of the golf ball. The method may include tracking the location of the user. The method may include displaying the distance between the location of the user and a landmark on the display device.

**[0006]** Other systems, methods, features and advantages of the invention will be, or will become, apparent to one of ordinary skill in the art upon examination of the following figures and detailed description. It is intended that all such additional systems, methods, features and advantages be included within this description and this summary, be within the scope of the invention, and be protected by the following claims.

**BRIEF DESCRIPTION OF THE DRAWINGS**

**[0007]** The invention can be better understood with reference to the following drawings and description. The components in the figures are not necessarily to scale, emphasis instead being placed upon illustrating the principles of the invention. Moreover, in the figures, like reference numerals designate corresponding parts throughout the different views.

**[0008]** FIG. 1 shows an embodiment of the disclosed system;

**[0009]** FIG. 2 is a schematic diagram of the embodiment of FIG. 1;

**[0010]** FIG. 3 shows a golf ball provided with communication components;

**[0011]** FIG. 4 shows a cross section of the golf ball of FIG. 3;

**[0012]** FIG. 5 shows a golfer wearing the system shown in FIGS. 1-2 and hitting the golf ball of FIGS. 3-4;

**[0013]** FIG. 6 shows an enhanced image of the golf ball imposed upon the golfer's real world view;

**[0014]** FIG. 7 shows information displayed on the eyeglasses of FIGS. 1-2; and

**[0015]** FIG. 8 shows a method of displaying an enhanced image of the golf ball imposed upon the golfer's real world view according to an embodiment.

## DETAILED DESCRIPTION

**[0016]** A system for tracking a golf ball is disclosed. The system may track the trajectory of a golf ball and display an enhanced image of the golf ball on a display such that the enhanced image is imposed upon a user's real world view. Displaying an enhanced image of the golf ball may help a user view the trajectory of the golf ball and find the golf ball after the golf ball lands. In some embodiments, the system may display an enhanced image of the golf ball on a heads-up display configured to be worn on a person's head. For example, the heads-up display may include a pair of eyeglasses having a lens. By displaying an enhanced image of the golf ball on the lens, the user may view the enhanced image while remaining hands-free. The enhanced image may include at least a portion of the trajectory of the golf ball. Thus, the enhanced image may facilitate tracking the trajectory of the golf ball, which may help the user to compare the golf ball's trajectory with an ideal trajectory. The enhanced image may also help the user see where the golf ball lands, which may help a user find the golf ball. The system may display other information, such as launch and flight information about the ball, on the heads-up display.

**[0017]** FIGS. 1 and 2 illustrate an embodiment of a system **100** for tracking a golf ball. System **100** may include a display device configured to be worn on a person's head. As shown in FIG. 1, the display device may include a pair of eyeglasses **102**. For example, the display device may include any of the head mounted displays described in U.S. Pat. No. 7,595,933, entitled Head Mounted Display System, issued to Tang on Sep. 29, 2009, the disclosure of which is hereby incorporated by reference in its entirety. A display system **208** may be associated with eyeglasses **102** to display images to the user. System **100** may include a golf ball tracking system **200** to track the location of a golf ball. System **100** may include a user tracking system **206** to track the location of the user to help navigate and/or determine distances between the user and landmarks, such as the next pin on the golf course. System **100** may include a camera **204** configured to capture and record images of the user's real world view to determine where to display enhanced images to the user such that the enhanced images are imposed upon the user's real world view. System **100** may include an interface **114** to enable a user to communicate with system **100**. System **100** may include at least one processor **202** configured to control camera **204**, golf ball tracking system **200**, user tracking system **206**, and/or display system **208**. In some embodiments, processor **202** may be coupled to camera **204**, golf ball tracking system **200**, user tracking system **206**, and/or display system **208**. In some embodiments, processor **202** may be configured to communicate with camera **204**, golf ball tracking system **200**, user tracking system **206**, and/or display system **208**. In some embodiments, system **100** may include more than one processor. For example, in some embodiments, a separate processor may be included for each component of system **100**.

**[0018]** While the embodiment of FIG. 1 includes eyeglasses **102**, other embodiments may include other types of display devices configured to be mounted on a person's head. For example, system **100** may include a visor, helmet, or goggles. The type of display device may be selected based on a variety of factors. For example, the type of display device may be selected based on the type of environment system **100** is meant to be used in. Components of system **100** may be mounted to eyeglasses **102**. Eyeglasses **102** may be hollow

such that components of system **100** may be housed within eyeglasses **102**. In some embodiments, eyeglasses **102** may include a removable cover **118** for allowing access to any components mounted within eyeglasses **102**. Eyeglasses **102** may include one or more lenses. FIG. 1 shows eyeglasses **102** with a single lens **104**. In some embodiments, lens **104** may include a partially reflective mirror. The partially reflective mirror may allow the real world to be seen through the reflected surface such that a transparent image may be imposed upon a real world view.

**[0019]** Display system **208** may be mounted on and housed within eyeglasses **102**. In some embodiments, display system **208** may include optical components, projecting components, imaging devices, power sources, and/or light sources. For example, display system **208** may include the components as described in U.S. Pat. No. 7,595,933. In some embodiments, display system **208** may include components that display images. For example, display system **208** may include a display element, such as a flat panel display or a liquid crystal display, as described in U.S. Pat. No. 7,595,933. In some embodiments, lens **104** may include a lens system that relays images to a user's eye from a display element.

**[0020]** User tracking system **206** may include one or more user location sensors **120**. User location sensor **120** may sense the location of the user. User location sensor **120** may be mounted on and housed within eyeglasses **102**. User location sensor **120** may be positioned in any suitable position. The type of user location sensor may include any suitable type of sensor. For example, user location sensor **120** may include a global positioning system receiver. The location, number, and type of user location sensor(s) may be selected based on a number of factors. For example, the type of user location sensor(s) may be selected based on the other types of components included in system **100**. In some embodiments, processor **202** may be configured to communicate with user location sensor **120** to determine the location of the user on a golf course and to determine the distance between the user and a landmark on the golf course. For example, in some embodiments, processor **202** may be configured to communicate with user location sensor **120** to determine the distance between the user and the next pin on the course. Such information would help a user find his yardages during a round of golf.

**[0021]** Golf ball tracking system **200** may include one or more golf ball sensors. The golf ball sensor may be configured to detect the golf ball. The golf ball sensor may be mounted on or housed within eyeglasses **102**. For example, as shown in FIG. 1, a golf ball sensor **110** may be mounted such that golf ball sensor **110** is exposed through an opening **112** in eyeglasses **102**. FIG. 1 shows golf ball sensor **110** as being mounted such that it will be positioned above the user's left eye when a user wears eyeglasses **102**. In other embodiments, golf ball sensor may be positioned in any suitable position. The location and number of golf ball sensors may be selected based on a number of factors. For example, the location of the golf ball sensor may be selected based on the positioning of other components and/or the sensitivity of the golf ball sensor.

**[0022]** In some embodiments, the golf ball sensor may include a reflective sensor capable of detecting the location of a golf ball without any communication components being provided within the golf ball. For example, the golf ball sensor may include radar, LIDAR, optical, and/or sonar sensors. In some embodiments, the golf ball tracking system may

include communication components provided inside and/or on the golf ball. Such golf ball tracking systems may include a golf ball sensor capable of detecting the location of a golf ball by detecting a tracking component provided within the golf ball. For example, the golf ball tracking system may include a radio-frequency identification system, a BLUE-TOOTH technology system, an infrared system, and/or global positioning system receiver.

**[0023]** In some embodiments, camera **204** may act as the golf ball tracking system. Camera **204** may find the contrast difference between the golf ball and the background of the ball as the golf ball travels. For example, camera **204** may find the contrast difference between the golf ball and the sky as the golf ball flies through the air.

**[0024]** In some embodiments, the golf ball tracking system may include a special coating on the golf ball. Such golf ball tracking systems may include a golf ball sensor capable of detecting the location of a golf ball by detecting the special coating provided on the golf ball. The special coating may include an ultraviolet sensitive paint and the golf ball sensor may include a camera configured to capture images illuminated by ultraviolet light only. For example, a UV transmitting, visible light blocking filter may be included over the camera lens so that only ultraviolet passes through the filter and all visible light is absorbed by the filter.

**[0025]** In some embodiments, the golf ball sensor and the user location sensor may include the same type of sensor. For example, the golf ball sensor and the user location sensor may both include an infrared system. Embodiments of golf ball tracking systems are described in more detail below.

**[0026]** Camera **204** may capture and record images from the user's viewpoint. The camera may include any suitable type of camera. The type of camera may be selected based on a variety of factors. For example, the type of camera may be selected based on the type of display included in the system or the type of golf ball tracking system used in the system. The camera may be mounted on or inside eyeglasses **102**. For example, as shown in FIG. 1, a camera may be mounted inside eyeglasses **102** with a camera lens **106** exposed through an opening **108** in eyeglasses **102**. FIG. 1 shows camera lens **106** as being mounted so that it will be positioned above the user's right eye when a user wears eyeglasses **102**. In other embodiments, the camera may be positioned in any other suitable position. The location of the camera may be selected based on a number of factors. For example, the location of the camera may be selected to provide the camera lens in a position close to the user's eye so that the view from the camera is similar to the view from the user's eye.

**[0027]** In some embodiments, processor **202** may be configured to process information relayed to and from the golf ball sensor and/or the communication component provided with the golf ball. Processor **202** may use this information to determine the location of the golf ball. In some embodiments, the processor may also be configured to control display system **208**. As a result, the processor may control the images shown by the display. In some embodiments, processor **202** may be configured to process information relayed to and from user location sensor **120**. The processor may use this information to determine the location of the user. In some embodiments, the processor may determine the distance between the user and a landmark, such as the pin or a restroom. In some embodiments, processor **202** may be configured to process information relayed to processor **202** from camera **204**. Processor **202** may use this information to display images cap-

tured and recorded by the camera to the user. Processor **202** may be configured to display enhanced images to the user.

**[0028]** In some embodiments, the system may include an interface **114** configured to communicate with components of the system. In some embodiments, the interface may be in communication with golf ball tracking system **200**, camera **204**, and/or eyeglasses **102** either directly or through processor **202**. Interface **114** may be in communication with processor **202**, golf ball tracking system **200**, camera **204**, and/or eyeglasses **102** either wirelessly or by wire. For example, FIG. 1 shows wire **116** extending through an opening **120** in eyeglasses **102**. Wire **116** may couple interface **114** to processor **202**. Interface **114** may provide the user with a way to control system **100**. In some embodiments, interface **114** may have an interface display. Such an interface display may show information about control settings and commands for system **100**. In some embodiments, interface **114** may have inputs for providing data and control signals to system **100**. For example, interface **114** may have buttons. In some embodiments, system **100** may include a touch screen that provides both an interface display and an input. In some embodiments, a user may wear eyeglasses **102** and put interface **114** in his pocket during use.

**[0029]** As discussed above, golf ball tracking system **200** may include a golf ball provided with communication components that are configured to communicate with a golf ball sensor. FIGS. 3 and 4 show a golf ball **300** that may be provided with communication components. Golf ball may include any suitable type of golf ball. For example, in some embodiments, golf ball **300** may be a one-piece golf ball. In other embodiments, golf ball **300** may be a multi-piece golf ball, such as a 2-piece or 3-piece golf ball. Golf ball **300** may have an outer surface including dimples **302**. Golf ball **300** may be provided with communication components including emitting diodes **304** and a microchip **400**. For example, the communication components may include those described in U.S. Pat. No. 6,634,959, entitled Golf Ball Locator, issued to Kuesters on Oct. 21, 2003, the disclosure of which is hereby incorporated by reference in its entirety, and as described in U.S. Pat. No. 5,564,698, entitled Electromagnetic Transmitting Hockey Puck, issued to Honey et al. on Oct. 15, 1996, the disclosure of which is hereby incorporated by reference in its entirety. Emitting diodes **304** may be disposed on the outer surface of golf ball **300**. FIG. 4 shows a cross-sectional view of golf ball **300**. As shown in FIG. 4, microchip **400** may be disposed inside golf ball **300**. Emitting diodes **304** may be connected to microchip **400** by wires **402**. In some embodiments, microchip **400** may be configured to power and control emitting diodes **304**. In some embodiments, microchip **400** may be configured to communicate with processor **202**. For example, microchip **400** may be configured to communicate with processor **202** via wireless signals. In some embodiments, microchip **400** may include a power source, timing circuits, on/off switches, a pulsing circuit, and/or shock sensors to control the powering of emitting diodes **304**. In such embodiments, the shock sensors may be configured to detect movement of golf ball **300**. Accordingly, movement of golf ball **300** may trigger the on/off switch to power emitting diodes **304**. To conserve power, timing circuits may be configured to control how long emitting diodes **304** are powered. Thus, shock sensors may detect when a golf club strikes golf ball **300**, which may trigger the on/off switch to power emitting diodes **304** while golf ball **300** is in flight. After a prede-

terminated amount of time, the timing circuits may trigger the on/off switch to shut off power to emitting diodes 304.

[0030] In embodiments in which golf ball 300 includes emitting diodes 304, golf ball sensor 110 may be configured to detect signals from emitting diodes 304. For example, emitting diodes 304 may include infrared emitting diodes and golf ball sensor 110 may include an infrared receiver. Golf ball sensor 110 may transmit this data to processor 202. Processor 202 may be configured to use this data to determine the location of emitting diodes 304, and thus, the location of golf ball 300. In some embodiments, in place of or in addition to golf ball sensor 110, camera 204 may be configured to detect emissions from emitting diodes 304. In some embodiments, in place of or in addition to golf ball sensor 110, multiple golf ball sensors may be provided in the location in which the golf ball is to be tracked. For example, multiple golf ball sensors may be provided in various positions on a golf course. In such embodiments, the position of the golf ball sensors may be known and the golf ball sensors may be used to determine the location of the golf ball by detecting emissions from emitting diodes 304.

[0031] FIG. 5 illustrates a user 500 wearing eyeglasses 102 while using a golf club 508 to hit a golf ball 300 off of a tee 504 in a tee box 506. FIG. 6 shows the user's view after he hits golf ball 300. Eyeglasses 102 provide an enhanced image of golf ball 300 imposed upon the user's real world view such that the enhanced image's position matches the position of golf ball 300. In FIG. 6, the user's real world view through lens 104 includes golf ball 300, a tree 514, and a pond 512 disposed within user's line of sight. The enhanced image adds a comet tail 600 to golf ball 300 as golf ball 300 flies through the air toward tree 514 and pond 512. Comet tail 600 may lag behind golf ball 300 such that comet tail 600 stays visible after golf ball 300 lands. Comet tail 600 may represent at least a portion of the trajectory of golf ball 300. In some embodiments, comet tail 600 may represent the entire trajectory of golf ball 300. As a result, user 500 may see the entire trajectory of golf ball 300 at least temporarily after golf ball 300 lands.

[0032] FIG. 8 shows a method 800 of displaying an enhanced image of the golf ball imposed upon the golfer's real world view according to an embodiment. The steps of method 800 may be performed in any order. Step 802 may include capturing and recording images from the user's viewpoint. Step 804 may include transmitting the recorded images to processor 202. Camera 204 may perform steps 802 and 804. Step 806 may include tracking the location of golf ball 300. Golf ball tracking system 200 and/or processor 202 may perform step 804. For example, in the embodiment discussed above with reference to FIGS. 3 and 4, hitting golf ball 300 may trigger shock sensors. As a result, on/off switches may cause microchip 400 to power emitting diodes 304, which may cause emitting diodes 304 to pulse. Golf ball sensor 110 may detect the pulses and transmit data to processor 202. Processor 202 may use the transmitted data to determine the location of emitting diodes 304, and thus, the location of golf ball 300.

[0033] Step 808 may include displaying an enhanced image of golf ball 300 upon the user's real world view. In some embodiments, processor 202 may use the location of golf ball 300 and the images recorded by camera 204 to make display system 208 display an enhanced image of golf ball 300 to user 500. The enhanced image may be displayed such that the enhanced image overlays the user's real world view. In some

embodiments, the enhanced image may be transparent. In some embodiments, the enhanced image may be stereoscopic. In some embodiments, the enhanced image may be bigger and/or brighter than the recorded image. For example, the enhanced image may appear to be glowing. The enhanced image may be selected to make golf ball 300 and the trajectory of golf ball 300 stand out more to the user while allowing user to still see a real world view. As shown in FIG. 6, the enhanced image may include comet tail 600 trailing behind golf ball 300. Comet tail 600 may show the trajectory of golf ball 300 such that user 500 can compare the trajectory of golf ball 300 to an ideal trajectory. In some embodiments, display system 208 may display an ideal trajectory such that the trajectory of golf ball 300 may be compared with the ideal trajectory.

[0034] In some embodiments, processor 202 may use the location of golf ball 300 at various times to determine launch information and/or flight information about golf ball 300. In some embodiments, to determine launch information and/or flight information about golf ball 300, system 100 may use methods and components described in U.S. Patent Application Publication 2007/0021226, entitled Method of and Apparatus for Tracking Objects in Flight Such as Golf Balls and the Like, applied for by Tyroler and published on Jan. 25, 2007, the disclosure of which is hereby incorporated by reference in its entirety. In some embodiments, to determine launch information and/or flight information about golf ball 300, system 100 may use methods and components described in U.S. Patent Application Publication 2005/0233815, entitled Method of Determining a Flight Trajectory and Extracting Flight Data for a Trackable Golf Ball, applied for by McCreary et al. and published on Oct. 20, 2005, the disclosure of which is hereby incorporated by reference in its entirety. In some embodiments, to determine launch information and/or flight information about golf ball 300, system 100 may use methods and components described in U.S. Patent Application Publication 2010/0151955, entitled Global Positioning System Use for Golf Ball Tracking, applied for by Holden and published on Jun. 17, 2010, the disclosure of which is hereby incorporated by reference in its entirety. To determine launch information and/or flight information about golf ball 300, system 100 may use methods and components described in U.S. Patent Application Publication 2008/0254916, entitled Method of Providing Golf Contents in Mobile Terminal, applied for by Kim et al. and published on Oct. 16, 2008, the disclosure of which is hereby incorporated by reference in its entirety. FIG. 7 shows how information may be displayed to the user. For example, launch information, such as initial velocity, and the distance to the pin may be displayed on lens 104. In another example, lens 104 may display the ball spin rate and/or launch angle. By displaying information to user 500 on eyeglasses 102, user 500 may reference this information without having to pull out a device or without having to do anything other than look in front of his eye. Accordingly, the user may quickly and easily reference information without having to distract from other activities.

[0035] In some embodiments, system 100 may include a separate launch monitor configured to monitor and record data related to the golf ball, golf club, and/or golfer. For example, system 100 may include the launch monitor described in U.S. patent application Ser. No. 13/307,789, entitled Method and Apparatus for Determining an Angle of Attack from Multiple Ball Hitting, applied for by Ishii et al. and filed on Nov. 30, 2011, the disclosure of which is hereby

incorporated by reference in its entirety. The separate launch monitor may be in communication with processor 202.

[0036] User tracking system 206 may determine the location of user 500. For example, in embodiments in which global positioning system receiver 120 is included in eyeglasses 102, global positioning system receiver 120 may determine the location of user and transmit the location of the user to processor 202. Processor 202 may be configured to know the locations of various landmarks on a golf course. Processor 202 may be configured to determine the distance between the location of the user and the various landmarks on the golf course. For example, processor 202 may be configured to determine the distance between user 500 and the next pin on the golf course. Processor 202 may be configured to display this distance to user 500, as shown in FIG. 7. In some embodiments, the user may be a golfer wearing eyeglasses 102. In some embodiments, the user may be a caddy wearing eyeglasses 102 and watching a golfer. The caddy may use the system to help the golfer choose clubs, adjust his swing, and find golf balls. In some embodiments, the user may be a spectator wearing the eyeglasses and watching a golfer.

[0037] In some embodiments, system 100 may display an image of golf ball 300 and/or an image of user 500 on a representation of the golf course. Display system 208 may display these images to user 500 on eyeglasses 102 to help user 500 navigate and/or locate golf ball 300. To display the images, system 100 may use the methods and components described in U.S. Patent Application Publication 2007/0021226, U.S. Patent Application Publication 2005/0233815, U.S. Patent Application Publication 2010/0151955, and/or U.S. Patent Application Publication 2008/0254916.

[0038] While various embodiments of the invention have been described, the description is intended to be exemplary, rather than limiting and it will be apparent to those of ordinary skill in the art that many more embodiments and implementations are possible that are within the scope of the invention. Accordingly, the invention is not to be restricted except in light of the attached claims and their equivalents. Also, various modifications and changes may be made within the scope of the attached claims.

What is claimed is:

1. A system for tracking a golf ball and displaying an image, comprising:
  - a golf ball tracking system for tracking the location of a golf ball; and
  - a display device associated with the golf ball tracking system, the display device being configured to be worn on a user's head and including a display system configured to use the tracked location of the golf ball to display an enhanced image of the golf ball imposed upon the user's real world view.
2. The system according to claim 1, wherein the golf ball tracking system includes:
  - a golf ball including a signal emitter; and
  - a signal receiver disposed on the display device and configured to receive a signal emitted by the signal emitter, the signal receiver being coupled to the processor.
3. The system according to claim 1, further comprising a user interface.
4. The system according to claim 1, wherein the display device includes one of eyeglasses, a helmet, and a visor.

5. The system according to claim 1, further comprising a display system associated with the display device, the display system configured to display enhanced images imposed upon the user's real world view.

6. The system according to claim 5, wherein the enhanced images are transparent.

7. A system for tracking a golf ball and displaying an image, comprising:

- a display device configured to be worn on a person's head;
- a camera associated with the display device, the camera configured to capture and record images of the user's real world view;

- a golf ball tracking system configured to track the location of a golf ball;

- at least one processor configured to control at least one of the camera, the golf ball tracking system, and the display system; and

- wherein the display device includes a display system configured to display an enhanced image of a golf ball captured by the camera imposed upon the user's real world view.

8. The system according to claim 7, wherein the display device includes one of eyeglasses, a helmet, and a visor.

9. The system according to claim 7, further comprising a display system disposed adjacent a lens of the display device, the display system configured to display enhanced images imposed upon the user's real world view.

10. The system according to claim 7, wherein the golf ball tracking system includes a golf ball sensor configured to detect a golf ball, wherein the processor is configured to process information provided by the golf ball sensor to determine the location of the golf ball.

11. The system according to claim 10, further comprising a golf ball having a signal emitter, wherein the golf ball sensor is configured to detect the golf ball by detecting signals emitted from the signal emitter.

12. The system according to claim 7, further comprising a user tracking system configured to track the location of the user, the user tracking system being disposed on the display device.

13. The system according to claim 12, wherein the processor is configured to use information relayed by the user tracking system to determine the distance between the user and a landmark.

14. A method of tracking a golf ball and displaying an image, comprising:

- capturing and recording images from a user's viewpoint;
- transmitting the recorded images to a processor;

- tracking the location of a golf ball disposed within a viewer's line of sight; and

- displaying an enhanced image of the golf ball imposed upon the user's real world view, wherein the enhanced image is displayed on a display device configured to be worn on a user's head.

15. The method according to claim 14, wherein the enhanced image of the golf ball includes a comet tail disposed over at least a portion of the golf ball's trajectory.

16. The method according to claim 14, wherein the enhanced image of the golf ball includes an image of the golf ball in which the golf ball has been brightened and/or enlarged.

17. The method according to claim 14, further including displaying launch information of the golf ball on the display device.

**18.** The method according to claim **14**, wherein tracking the location of the golf ball includes emitting a signal from a signal emitter disposed within the golf ball and processing the signal to determine the location of the golf ball.

**19.** The method according to claim **14**, further comprising tracking the location of the user.

**20.** The method according to claim **19**, further comprising displaying the distance between the location of the user and a landmark on the display device.

\* \* \* \* \*