



US008113965B2

(12) **United States Patent**
Ban

(10) **Patent No.:** **US 8,113,965 B2**
(45) **Date of Patent:** ***Feb. 14, 2012**

(54) **GOLF CLUB HEAD**

(75) Inventor: **Wataru Ban**, Chichibu (JP)

(73) Assignee: **Bridgestone Sports Co., Ltd.**, Tokyo (JP)

(*) Notice: Subject to any disclaimer, the term of this patent is extended or adjusted under 35 U.S.C. 154(b) by 0 days.

This patent is subject to a terminal disclaimer.

(21) Appl. No.: **12/725,112**

(22) Filed: **Mar. 16, 2010**

(65) **Prior Publication Data**

US 2010/0317459 A1 Dec. 16, 2010

(30) **Foreign Application Priority Data**

Jun. 16, 2009 (JP) 2009-143671

(51) **Int. Cl.**

A63B 53/04 (2006.01)

(52) **U.S. Cl.** **473/330; 473/331**

(58) **Field of Classification Search** **473/324-350, 473/287-292**

See application file for complete search history.

(56) **References Cited**

U.S. PATENT DOCUMENTS

1,965,954 A	7/1934	Davis	
3,869,126 A	3/1975	Thompson	
4,768,787 A *	9/1988	Shira	473/331
5,029,864 A	7/1991	Keener	
5,190,289 A *	3/1993	Nagai et al.	473/327
5,437,088 A	8/1995	Igarashi	
5,618,239 A	4/1997	Rife	

5,688,190 A	11/1997	Rowland et al.	
5,690,561 A	11/1997	Rowland et al.	
5,709,616 A	1/1998	Rife	
5,792,004 A	8/1998	Nagamoto	
7,273,422 B2	9/2007	Vokey et al.	
7,674,188 B2 *	3/2010	Ban	473/330
7,780,548 B2 *	8/2010	Solheim	473/330
7,819,756 B2 *	10/2010	Ban et al.	473/330
7,828,671 B2 *	11/2010	Ban	473/331
7,901,297 B2 *	3/2011	Ban et al.	473/331
2005/0130761 A1	6/2005	Vokey et al.	
2005/0245329 A1	11/2005	Nishitani et al.	
2005/0250594 A1	11/2005	Nishitani et al.	
2008/0020859 A1	1/2008	Yamagishi et al.	
2008/0045351 A1	2/2008	Vokey et al.	
2008/0125241 A1	5/2008	Tateno et al.	
2008/0125242 A1	5/2008	Ban	
2008/0125243 A1	5/2008	Ban	
2008/0132351 A1	6/2008	Ban et al.	
2008/0132352 A1	6/2008	Ban	
2009/0176597 A1	7/2009	Yamagishi et al.	

FOREIGN PATENT DOCUMENTS

JP	08-000777 A	1/1996
JP	08-206260 A	8/1996
JP	08-229169 A	9/1996
JP	09-056855 A	3/1997
JP	09-070457 A	3/1997
JP	09-099120 A	4/1997

(Continued)

Primary Examiner — Sebastiano Passaniti

(74) *Attorney, Agent, or Firm* — Sughrue Mion, PLLC

(57) **ABSTRACT**

This invention provides a golf club head comprising a plurality of scorelines formed in its face. The golf club head is configured such that an angle θ of the side wall of the scoreline with respect to the face is 70° or less, the edge of the scoreline has a ridged portion projecting from the face, and a height H of the ridged portion from the face satisfies: $5 \mu\text{m} \leq H \leq 20 \mu\text{m}$.

3 Claims, 8 Drawing Sheets

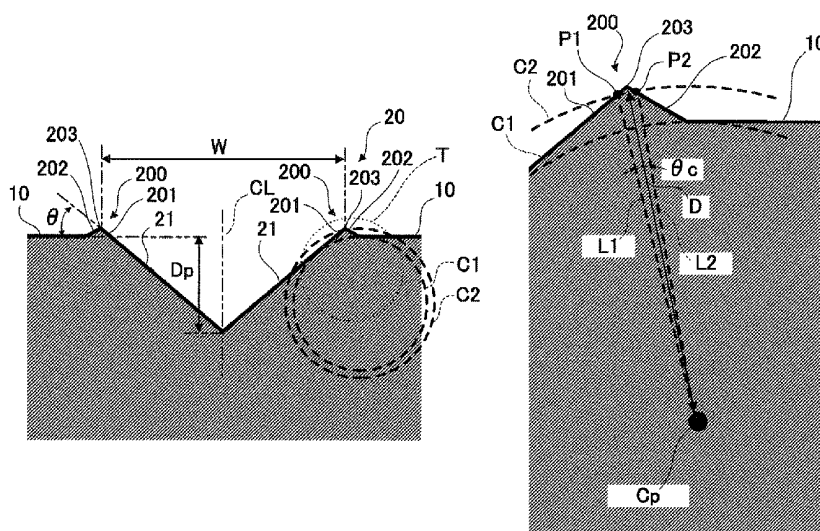

FOREIGN PATENT DOCUMENTS		
JP	09-253250 A	9/1997
JP	10-000250 A	1/1998
JP	10-000251 A	1/1998
JP	10-248974 A	9/1998
JP	02825022 B2	9/1998
JP	02926702 B2	5/1999
JP	2002-000779 A	1/2002
JP	2004-000674 A	1/2004
JP	2005-169129 A	6/2005
JP	2005-312619 A	11/2005
JP	2005-319019 A	11/2005
JP	2008-023178 A	2/2008
JP	2008-132168 A	6/2008
JP	2008-132169 A	6/2008
JP	2008-136619 A	6/2008
JP	2008-136833 A	6/2008

* cited by examiner

FIG. 1

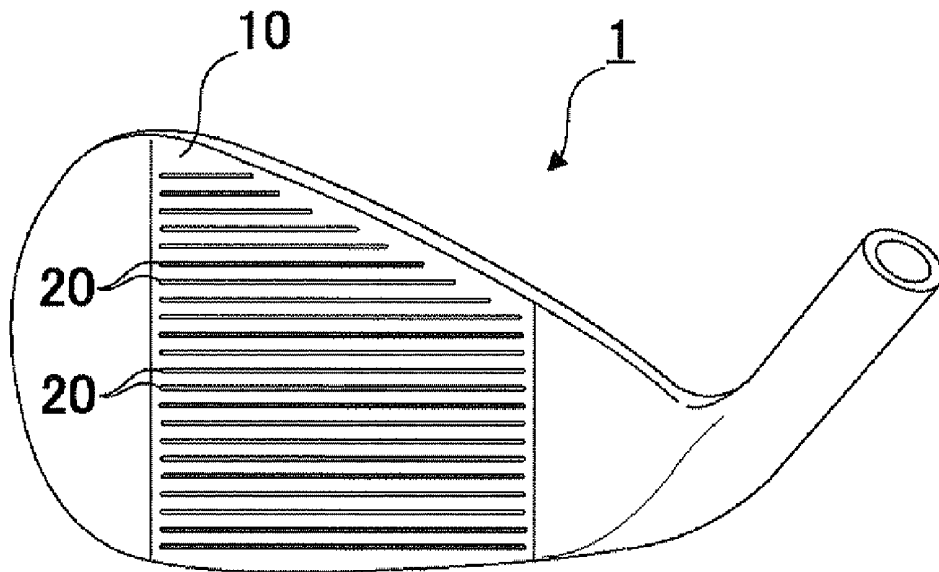

FIG. 2

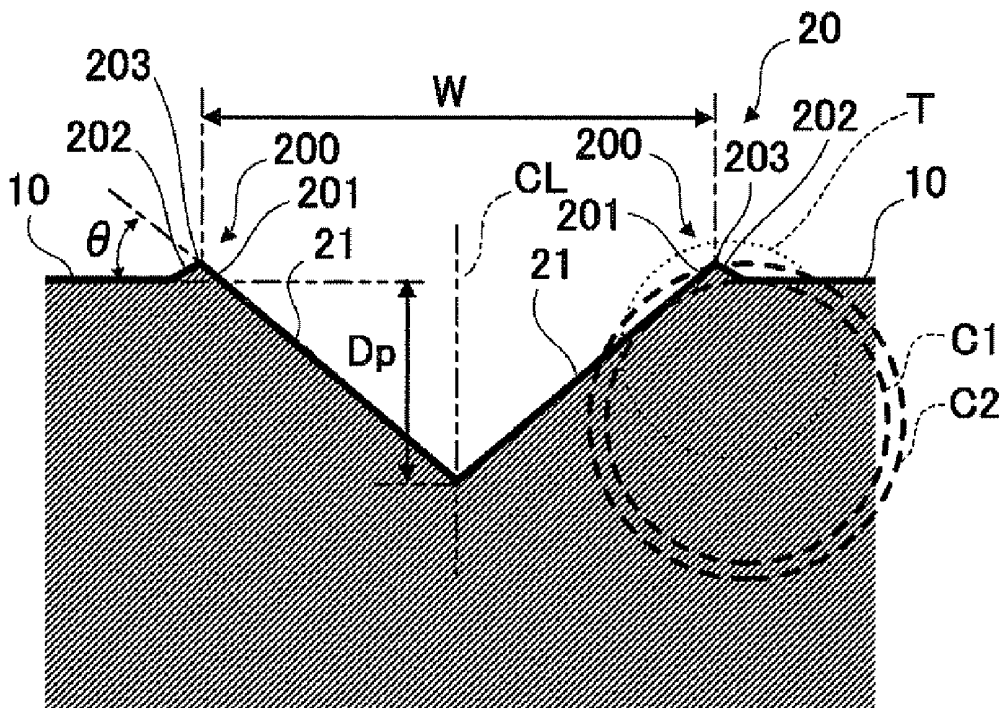

FIG. 3A

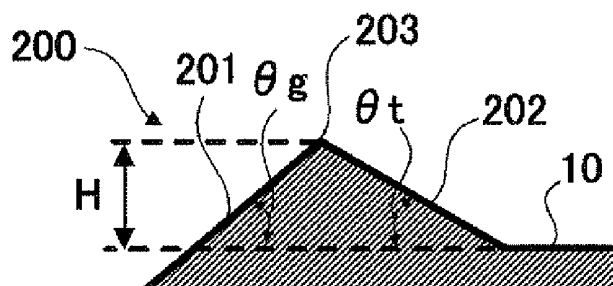

FIG. 3B

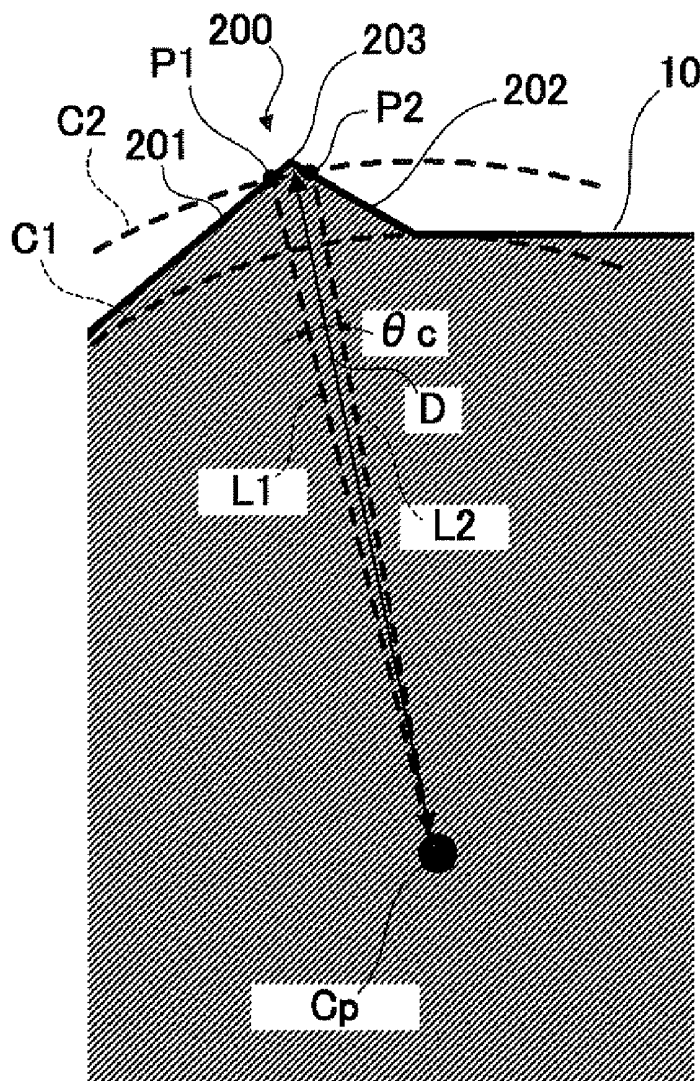

FIG. 4A

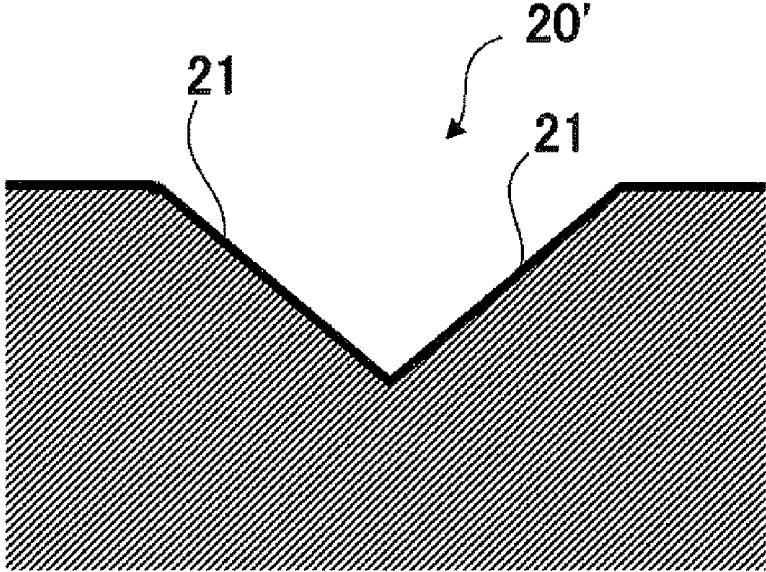

FIG. 4B

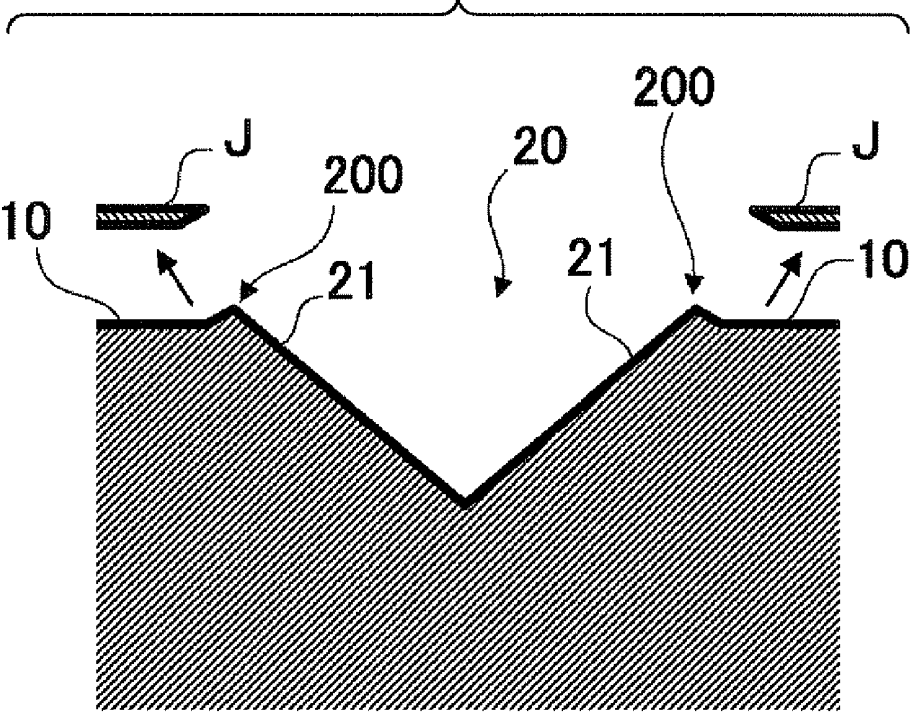

FIG. 5A

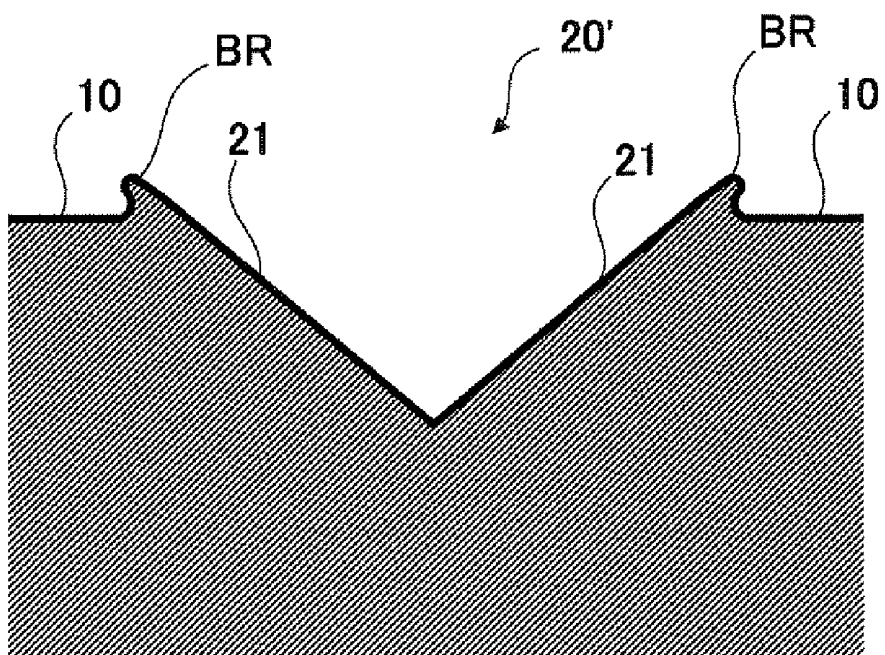

FIG. 5B

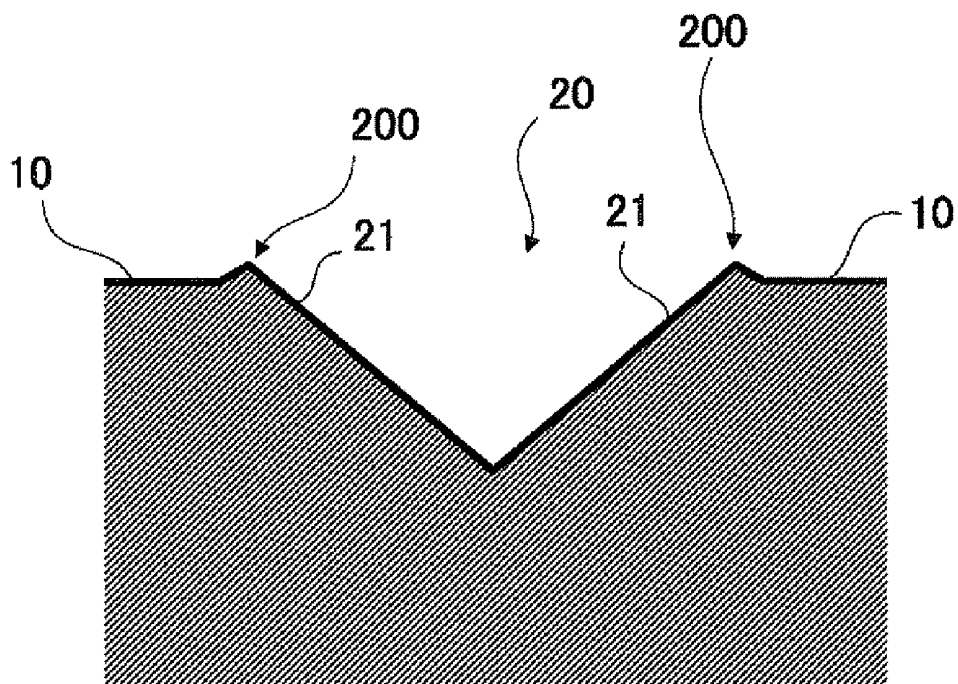

FIG. 6A

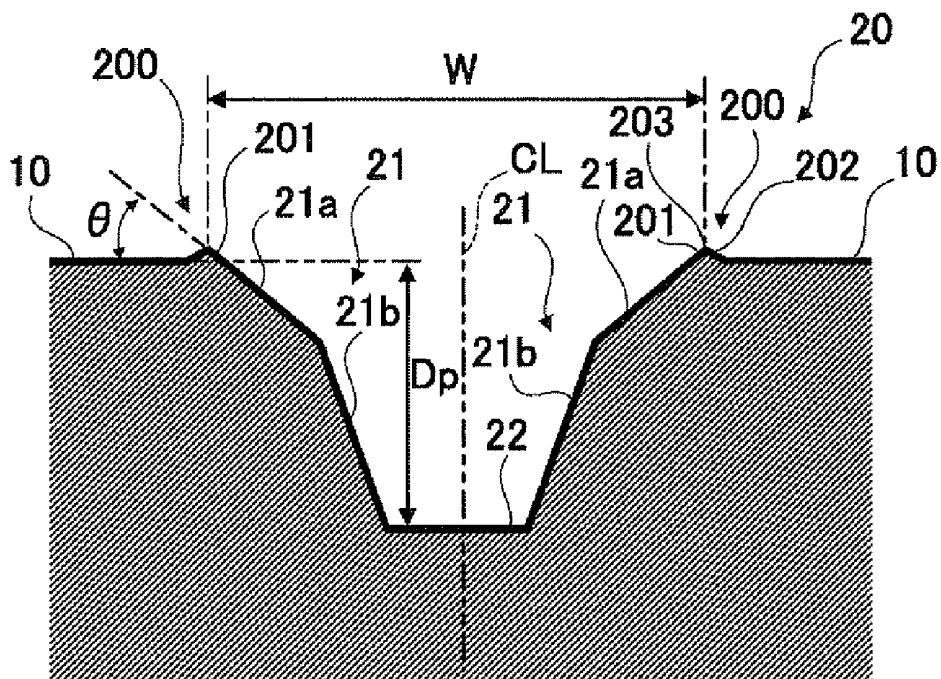
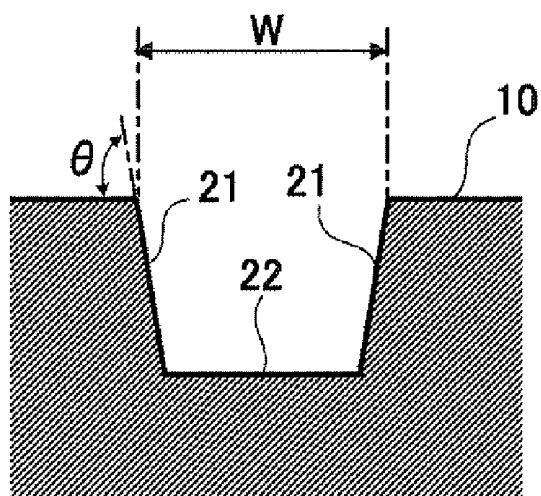

FIG. 6B



	CROSS-SECTIONAL SHAPE	θ (°)	H (μ m)	W (mm)	Ra (μ m)	P (mm)	A (mm ²)		
#1	SINGLE-STEP SIDE WALL	75	—	0.85	1.5	3.6	0.382		
#2		35	—				0.202		
#3		45	—				0.245		
#4	TWO-STEP SIDE WALL	35	5		2.5		1.5	0.202	0.202
#5					3.5				
#6					6.0				
#7					15				
#8					20				
#9		25							
#10		45	15		3				
#11					6				
#12					10				
#13					15				

FIG. 7

FIG. 8

	RULE CONFORMITY			EXPERIMENTAL RESULT		
	AREA RULE	TWO-CIRCLE RULE	SURFACE ROUGHNESS RULE	BACK SPIN AMOUNT	SCRATCH	
#1	x	x	○	A	E	
#2	○	○		D	E	A
#3					B	D
#4						C
#5			B	C		
#6		x	A	D		
#7		○	○	C	C	B
#8					B	C
#9				E		
#10				D	B	
#11					C	D
#12						E
#13				B	E	

FIG. 9A

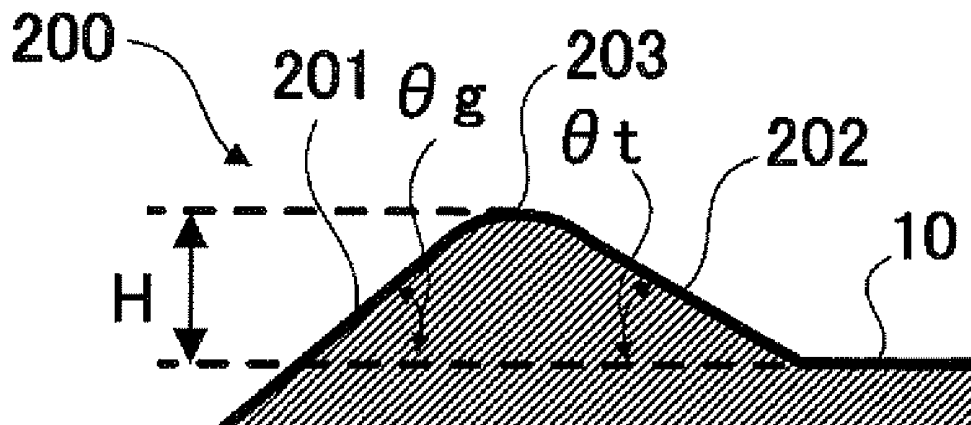
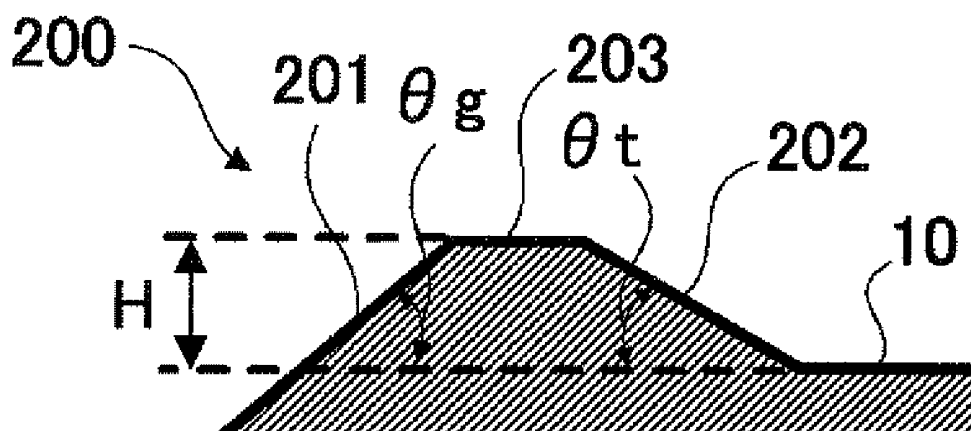

FIG. 9B



1

GOLF CLUB HEAD

BACKGROUND OF THE INVENTION

1. Field of the Invention

The present invention relates to a golf club head and, more particularly, to scorelines in the face.

2. Description of the Related Art

In general, a plurality of linear grooves are formed in the face of a golf club head so as to run parallel to each other in the toe-to-heel direction (see, for example, Japanese Patent Laid-Open Nos. 10-248974 and 2005-169129). These grooves are called, for example, scorelines, marking lines, or face lines (these grooves will be referred to as scorelines in this specification). These scorelines have the effect of increasing the amount of backspin on a struck golf ball, or suppressing a significant decrease in the amount of backspin on a struck golf ball upon a shot in rainy weather or that from the rough.

Typically, as an angle θ of the side wall of the scoreline with respect to the face widens, the amount of backspin on a struck ball can increase but the golf club head is prone to scratch the ball at the same time.

SUMMARY OF THE INVENTION

It is an object of the present invention to provide a golf club head which can obtain a larger amount of backspin on a ball while being prevented from scratching the ball.

According to the present invention, there is provided a golf club head comprising a plurality of scorelines formed in a face thereof, wherein an angle θ of a side wall of the scoreline with respect to the face is not more than 70° , an edge of the scoreline includes a ridged portion projecting from the face, and a height H of said ridged portion from the face satisfies $5 \mu\text{m} \leq H \leq 20 \mu\text{m}$.

Further features of the present invention will become apparent from the following description of exemplary embodiments with reference to the attached drawings.

BRIEF DESCRIPTION OF THE DRAWINGS

FIG. 1 is a perspective view of a golf club head 1 according to one embodiment of the present invention;

FIG. 2 is a sectional view of a scoreline 20 in a direction perpendicular to its longitudinal direction (toe-to-heel direction);

FIG. 3A is an enlarged sectional view of a ridged portion 200;

FIG. 3B is an enlarged view of a portion corresponding to a circle T in FIG. 2;

FIGS. 4A and 4B are explanatory views illustrating an example of a method of forming the ridged portions 200;

FIGS. 5A and 5B are explanatory views illustrating another example of the method of forming the ridged portions 200;

FIG. 6A is a sectional view illustrating another example of the cross-sectional shape of the scoreline 20;

FIG. 6B is a sectional view showing the cross-sectional shape of a scoreline of golf club head #1 used in an experiment involved;

FIG. 7 is a table showing the specifications of golf club heads #1 to #13 used in the experiment involved;

FIG. 8 is a table showing the rule conformities of golf club heads #1 to #13 and the experimental results obtained using them; and

2

FIGS. 9A and 9B are enlarged sectional views showing other examples of the shape of the ridged portion 200.

DESCRIPTION OF THE EMBODIMENTS

First Embodiment

FIG. 1 is a perspective view of a golf club head 1 according to one embodiment of the present invention. FIG. 1 exemplifies a case in which the present invention is applied to an iron type golf club head. The present invention is suitable for an iron type golf club head and, more particularly, for middle iron, short iron, and wedge type golf club heads. More specifically, the present invention is suitable for a golf club head with a loft angle of 25° (inclusive) to 70° (inclusive) and a head weight of 200 g (inclusive) to 320 g (inclusive). However, the present invention is also applicable to wood type and utility type golf club heads.

The golf club head 1 has a plurality of scorelines 20 formed in its face (its striking surface or striking face) 10. The scorelines 20 are linear grooves running parallel to each other in the toe-to-heel direction. Although the scorelines 20 run at equal intervals (equal pitches) in this embodiment, they may run at different intervals.

FIG. 2 is a sectional view of the scoreline 20 in a direction perpendicular to its longitudinal direction (toe-to-heel direction). In this embodiment, the cross-sectional shapes of the scoreline 20 are the same in its portions other than its two end portions (its toe-side end portion and heel-side end portion). In addition, the cross-sectional shapes of the scorelines 20 are the same.

The scoreline 20 has a pair of side walls 21. The side wall 21 forms a single face. The lower ends of the pair of side walls 21 are continuous with each other and therefore the scoreline 20 has a roughly V-shaped cross-section. The cross-sectional shape of the scoreline 20 is bilaterally symmetrical about its center line CL. A depth D_p is the distance from the face 10 to the deepest portion of the scoreline 20. A width W is of the scoreline 20 and is measured by the so-called 30 degrees measurement rule of athletic golf clubs. Since a rule concerning athletic golf clubs imposes limits on the depth D_p and the width W, the golf club head 1 is designed so as to satisfy that rule when it is used for an athletic golf club.

An angle θ is of the side wall 21 with respect to the face 10. In a scoreline without ridged portions 200 (to be described later), typically, if the angle θ is relatively wide, the amount of backspin on a ball is relatively large but the golf club head 1 is prone to scratch the ball at the same time. If the angle θ is relatively narrow, the amount of backspin on a ball is relatively small but the golf club head 1 is less prone to scratch the ball at the same time. In this embodiment, the angle θ is assumed to be 70° or less. Note that, when the angle θ is too narrow, a sufficient amount of backspin cannot be obtained. Thus, the angle θ is preferably 40° or more and is, more preferably, 45° or more.

Ridged portions 200 projecting from the face 10 are formed in the edges of the scoreline 20. The ridged portions 200 are uniformly formed so as to extend in the longitudinal direction of the scoreline 20. FIG. 3A is an enlarged sectional view of the ridged portion 200. In this embodiment, the ridged portion 200 has a triangular cross-section, an inner side wall 201 on the side of the center of the scoreline 20, and an outer side wall 202 on the side opposite to the center of the scoreline 20. Also in this embodiment, the inner side wall 201 and side wall 21 are continuous with each other on nearly the same plane.

In this embodiment, the ridged portions 200 are formed to increase the amount of backspin on a struck ball. That is, as

described above, the back spin amount on a struck ball typically increases or decreases nearly in proportion to the angle θ , but the formation of the ridged portions **200** makes it possible to obtain a sufficient amount of backspin even when the angle θ is relatively narrow.

A top **203** of the ridged portion **200** may be rounded off, as shown in FIG. 9A, so that the ridged portion **200** has a roughly triangular cross-section. Also, the top **203** may be shaped into a flat surface, as shown in FIG. 9B, so that the ridged portion **200** has a trapezoidal cross-section.

Referring to FIG. 3A, an angle θ_g is the interior angle between the face **10** and the inner side wall **201**, and an angle θ_t is the interior angle between the face **10** and the outer side wall **202**. To be more precise, the angles θ_g and θ_t are the interior angles between a virtual plane including the face **10** and the inner side wall **201** and outer side wall **202**, respectively. In this embodiment, the angle θ_g is equal to the above-mentioned angle θ . Note that $\theta_g > \theta_t$ in this embodiment. When $\theta_g > \theta_t$, it is advantageously possible to reduce wearing of the ridged portion **200**.

A height H is the distance from the face **10** to the top **203**. To be more precise, the height H is the length of the normal from the top **203** to a virtual plane including the face **10**. As the height H rises, the catchability between a ball and the ridged portion **200** upon striking the ball improves, and the amount of backspin on the ball can, in turn, increase. The height H is desirably $5 \mu\text{m}$ or more. On the other hand, the height H is too high, the golf club head **1** is prone to scratch a ball. In addition, it is stipulated that the face of an athletic golf club should have a surface roughness equal to a maximum height R_y of $25 \mu\text{m}$ or less. Thus, the height H is naturally $25 \mu\text{m}$ or less.

The area rule and two-circle rule concerning athletic golf clubs will be explained next. The area rule stipulates that the cross-sectional area of a scoreline and a pitch P between adjacent scorelines must satisfy: $\text{Cross-sectional Area } A (\text{inch}^2) / \text{Pitch } P (\text{inch}) \leq 0.003$. In accordance with the metric system, this rule is rewritten as: $\text{Cross-sectional Area } A (\text{mm}^2) / \text{Pitch } P (\text{mm}) \leq 0.0762$. When the golf club head **1** is used as an athletic golf club head, it is designed so as to satisfy this rule. Note that in this embodiment, the cross-sectional area A is the area of the region surrounded by a virtual line which connects the pair of side walls **21**, the pair of side walls **201**, and the pair of tops **203**. Also, the pitch P is given by: $P = W + S$ where S is the interval between adjacent scorelines. If the interval S between adjacent scorelines differs, the smaller value (the narrower interval) is selected.

The two-circle rule stipulates that the edge of a scoreline generally must fall within a virtual circle which has a radius of 0.011 inches (0.279 mm) and is concentric with a virtual circle which has a radius of 0.010 inches (0.254 mm) and is inscribed in both the side wall of the scoreline and the face. This two-circle rule admits, as an exception, a scoreline which has its edge falling outside a virtual circle with a radius of 0.011 inches but which satisfies the condition in which the included angle between two segments which connect the center of the virtual circle and two intersections between the virtual circle and the contour of the edge of the scoreline falling outside the virtual circle is 10° or less (to be referred to as the "maximum angle rule" hereinafter). However, the edge of the scoreline is prohibited from projecting in excess of 0.0113 inches (0.287 mm) from the center of the virtual circle (to be referred to as the "maximum projection rule" hereinafter). When the golf club head **1** is used as an athletic golf club head, it is designed so as to satisfy these rules.

Referring to FIG. 2, a virtual circle **C1** is a circle which has a radius of 0.010 inches and is inscribed in both the side wall

21 and the face **10**. Also, a virtual circle **C2** is a circle which has a radius of 0.011 inches and is concentric with the virtual circle **C1**. FIG. 3B is an enlarged view of a portion corresponding to a circle **T** in FIG. 2. A center point C_p is of the virtual circle **C1** (and the virtual circle **C2**). The ridged portion **200** partially falls outside the virtual circle **C2** and the contour of the portion falling outside the virtual circle **C2** and the virtual circle **C2** intersect with each other at points **P1** and **P2**. To satisfy the two-circle rule, an included angle θ_c between a virtual line **L1** which connects the points **P1** and C_p and a virtual line **L2** which connects the points **P2** and C_p needs to be 10° or less. In addition, in this embodiment, since a point farthest from the center point C_p corresponds to the top **203**, the distance between the center point C_p and the top **203** needs to be 0.0113 inches or less, that is, the ridged portion **200** needs to fall within a virtual circle (not shown) which has a radius of 0.0113 inches and a center at the center point C_p , in order to satisfy the two-circle rule.

An example of a method of forming the ridged portions **200** will be explained next. FIGS. 4A and 4B are explanatory views illustrating an example of a method of forming the ridged portions **200**. First, a face member which forms a face **10** is prepared. This face member is a member which forms a face portion if a golf club head is fabricated by separately forming a face portion and a body portion and assembling them; is a member which forms a body portion if a golf club head is fabricated by separately forming a body portion and a sole portion and assembling them; or is a single member which forms a golf club head if it is formed from that member alone.

Next, a temporary scoreline **20'** is primarily formed, as shown in FIG. 4A. Subsequently, unnecessary portions are eliminated to form a face **10** and ridged portions **200**. The temporary scoreline **20'** can be formed by, for example, a cutting process, a forging process, or a casting process. Examples of a method of eliminating the unnecessary portions **J** are a cutting process, a polishing process, a shotblasting process, a shot peening process, and chemical processes such as acid washing.

The ridged portions **200** may be projections produced in the process of forming the scoreline **20** or the ones formed by machining the projections. FIGS. 5A and 5B are explanatory views illustrating another example of the method of forming the ridged portions **200**. After a face member is prepared, a temporary scoreline **20'** is primarily formed, as shown in FIG. 5A. At this time, projections **BR** are purposely formed in the edges of the scoreline **20'**. When the scoreline **20'** is formed by a cutting process by an NC milling machine, the projections **BR** are, for example, burrs formed by rough machining in which, for example, the feed speed of a tool is relatively high or a large cutting depth is set. Ridged portions **200** are formed by appropriately adjusting the shapes of the projections **BR**, as shown in FIG. 5B. Examples of a method of forming the ridged portions **200** from the projections **BR** are a cutting process, a polishing process, a shotblasting process, a shot peening process, and chemical processes such as acid washing. The projections **BR** can also be used intact as the ridged portions **200** depending on their shapes. In this case, both the scoreline **20** and the ridged portions **200** can be formed at once.

Second Embodiment

Although the scoreline **20** has a roughly V-shaped cross-section in the above-described first embodiment, another cross-sectional shape can also be adopted. FIG. 6A is a sectional view illustrating another example of the cross-sectional

shape of a scoreline **20**. The same reference numerals as in the above-described first embodiment denote the same constituent components of the scoreline **20** in the second embodiment, and a description thereof will not be given. Referring to FIG. 6A, the scoreline **20** has a pair of side walls **21** and a bottom wall **22**. In this embodiment, the side walls **21** include a side wall **21a** on the side of a face **10** and a side wall **21b** on the side opposite to the face **10**. An angle θ is of the side wall **21a** with respect to the face **10**.

The side wall **21a** has its upper end which is continuous with an inner side wall **201** of a ridged portion **200**. In this embodiment, the side wall **21a** and inner side wall **201** are continuous with each other on nearly the same plane. Hence, the angle θ is equal to an angle θ_g . The side wall **21b** has its upper end which is continuous with the lower end of the side wall **21a**, and its lower end which is continuous with the bottom wall **22**. The bottom wall **22** is parallel to the face **10**.

In this embodiment, a virtual circle **C1** in the two-circle rule need only be assumed to be inscribed in the side wall **21a** of the side walls **21**. Also, a cross-sectional area **A** of the scoreline **20** is the area of the region surrounded by a virtual line which connects the pair of side walls **21** (the upper side wall **21a** and lower side wall **21b**), the bottom wall **22**, the pair of side walls **201**, and a pair of tops **203**. In this embodiment, the volume of the scoreline **20** is easily increased because the cross-sectional area of the scoreline **20** in this embodiment is larger than that of the scoreline **20** in the above-described first embodiment.

Third Embodiment

The amount of backspin on a struck ball can be further increased by roughing a face **10**. Examples of a method of roughing the face **10** are milling and shotblasting. The amount of backspin is effectively increased as long as the face **10** has a surface roughness equal to an arithmetic average roughness (Ra) of 3.0 μm or more. However, note that it is stipulated that the face of an athletic golf club should have a surface roughness equal to an arithmetic average roughness (Ra) of 4.57 μm or less. Thus, when the golf club head **1** is used for an athletic golf club, the face naturally has a surface roughness equal to an arithmetic average roughness (Ra) of 4.57 μm or less.

Example

Thirteen golf club heads #**1** to #**13** having different specifications such as those associated with scorelines were fabricated, and test shots took place using golf clubs equipped with the respective golf club heads. Each golf club head was a wedge with a loft angle of 58°. FIG. 7 is a table showing the specifications of golf club heads #**1** to #**13** used in an experiment involved.

Referring to FIG. 7, "Cross-sectional Shape" indicates the cross-sectional shapes of scorelines of the respective golf club heads. "Single-step Side Wall" in golf club head #**1** indicates that a golf club head has scorelines with a cross-sectional shape formed by a bottom wall **22** and side walls **21** each of which forms a single face, shown in FIG. 6B. Golf club head #**1** has no ridged portions **200**. "Two-step Side Wall" in golf club heads #**2** to #**13** indicates that a golf club head has scorelines with a cross-sectional shape formed by a bottom wall **22** and side walls **21** each of which forms two faces (side walls **21a** and **21b**), as shown in FIG. 6A. Note that the scorelines of golf club heads #**2** and #**3** have no ridged portions **200**. Referring to FIG. 7, " θ ", "**H**", and "**W**" indicate the angle θ , the height **H** of the ridged portion **200**, and the

width **W** of the scoreline **20**, respectively, shown in FIGS. 2, 3A and 6A. "Ra" indicates the arithmetic average roughness of the face; "P", the pitch of scorelines; and "A", the cross-sectional area of a scoreline.

FIG. 8 is a table showing the rule conformities of golf club heads #**1** to #**13** and the experimental results obtained using them. "Rule Conformity" indicates the rule conformity of an athletic golf club head. "Surface Roughness Rule" is satisfied when the face has a surface roughness equal to an arithmetic average roughness (Ra) of 4.57 μm or less and to a maximum height Ry of 25 μm or less.

An experiment (test shots) took place by striking each golf club a plurality of times from a spot spaced apart from the green by 40 yards toward the green. The amounts of backspin on a golf ball were evaluated relatively on a scale of five grades A to E (A is best and E is worst) based on the degrees of stop of the golf ball on the green by visual observation. The degrees of scratch of the golf ball were evaluated relatively on a scale of five grades A to E (A is best and E is worst) by visual observation as well. The amount backspin on a ball and the degree of scratch of the ball are preferably C or higher.

Golf club head #**1** has an angle θ of 75° and this means that it produces a large amount of backspin on a ball but scratches the ball to a large degree. Thus, the angle θ is desirably 70° or less. At the same time, the angle θ is preferably 45° or more from the viewpoint of increasing the amount of backspin, as can be seen from a comparison between golf club heads #**7** and #**13**. The formation of ridged portions **200** increases the amount of backspin, as can be seen from a comparison between golf club head #**2** and golf club heads #**7** to #**9** and a comparison between golf club head #**3** and golf club heads #**10** to #**13**.

The experimental results obtained using golf club heads #**7** to #**9** reveal that the amount of backspin on a ball increases in proportion to the height **H** of the ridged portion **200** but the degree of scratch of the ball increases, so golf club head #**9** has grade E in the degree of scratch. Thus, the height **H** is desirably 20 μm or less from the viewpoint of making a golf club head less prone to scratch a ball. The experimental results obtained using golf club heads #**10** to #**13** reveal that the height **H** is desirably 5 μm or more from the viewpoint of ensuring a given amount of backspin.

As for the surface roughness Ra, the experimental results obtained using golf club heads #**4** to #**6** reveal that the amount of backspin increases as the face becomes rougher, so golf club head #**5** (Ra=3.5 μm) had an especially good result (grade B) while satisfying the surface roughness rule. Thus, the surface roughness Ra is preferably 3.0 μm or more.

While the present invention has been described with reference to exemplary embodiments, it is to be understood that the invention is not limited to the disclosed exemplary embodiments. The scope of the following claims is to be accorded the broadest interpretation so as to encompass all such modifications and equivalent structures and functions.

This application claims the benefit of Japanese Patent Application No. 2009-143671, filed Jun. 16, 2009, which is hereby incorporated by reference herein in its entirety.

What is claimed is:

1. A golf club head comprising a plurality of scorelines formed in a face thereof, wherein
 - an angle θ of a side wall of the scoreline with respect to the face is not more than 70°;
 - an edge of the scoreline includes a ridged portion projecting from the face;
 - a height **H** of said ridged portion from the face satisfies:

$$5 \mu\text{m} \leq H \leq 20 \mu\text{m},$$

7

said ridged portion includes a first side wall on a side of the scoreline and a second side wall on a side opposite to the scoreline, and

an interior angle θ_g between the face and said first side wall and an interior angle θ_t between the face and said second side wall have a relation:

$$\theta_g > \theta_t.$$

2. A golf club head comprising a plurality of scorelines formed in a face thereof, wherein

an angle θ of a side wall of the scoreline with respect to the face is not more than 70° ,

an edge of the scoreline includes a ridged portion projecting from the face,

a height H of said ridged portion from the face satisfies:

$$5 \mu\text{m} \leq H \leq 20 \mu\text{m},$$

a cross-sectional area A (inch²) of the scoreline, a width W (inch) of the scoreline measured by a 30 degrees measurement rule, and a distance S (inch) between adjacent scorelines satisfy:

$$A/(W+S) \leq 0.0025$$

letting P1 and P2 be two intersections between a contour of a portion, in the edge of the scoreline, which falls outside a second virtual circle which has a radius of 0.011 inch and is concentric with a first virtual circle which has a radius of 0.010 inch and is inscribed in both the side wall of the scoreline and the face, and Cp be a center point of both the first virtual circle and the second virtual circle, an included angle between a virtual line which connects the point P1 and the point Cp and a virtual line which connects the point P2 and the point Cp is not more than 10° , and

8

the edge of the scoreline falls within a circle which has a radius of 0.0113 inch and is concentric with both the first virtual circle and the second virtual circle.

3. A golf club head comprising a plurality of scorelines formed in a face thereof, wherein

an angle θ of a side wall of the scoreline with respect to the face is not more than 70° ,

an edge of the scoreline includes a ridged portion projecting from the face,

a height H of said ridged portion from the face satisfies:

$$5 \mu\text{m} \leq H \leq 20 \mu\text{m},$$

the ridged portion extends lengthwise along the edge of the scoreline between a toe portion and a heel portion,

a cross-sectional area A (inch²) of the scoreline, a width W (inch) of the scoreline measured by a 30 degrees measurement rule, and a distance S (inch) between adjacent scorelines satisfy:

$$A/(W+S) \leq 0.0025$$

letting P1 and P2 be two intersections between a contour of a portion, in the edge of the scoreline, which falls outside a second virtual circle which has a radius of 0.011 inch and is concentric with a first virtual circle which has a radius of 0.010 inch and is inscribed in both the side wall of the scoreline and the face, and Cp be a center point of both the first virtual circle and the second virtual circle, an included angle between a virtual line which connects the point P1 and the point Cp and a virtual line which connects the point P2 and the point Cp is not more than 10° , and

the edge of the scoreline falls within a circle which has a radius of 0.0113 inch and is concentric with both the first virtual circle and the second virtual circle.

* * * * *