



US 20110118050A1

(19) **United States**

(12) **Patent Application Publication**
Brown, JR. et al.

(10) **Pub. No.: US 2011/0118050 A1**

(43) **Pub. Date: May 19, 2011**

(54) **GOLF SHAFT WITH ROUGHENED SURFACE**

Publication Classification

(75) Inventors: **Donald Collins Brown, JR.**, San Diego, CA (US); **Armando Herrera**, Chula Vista, CA (US)

(51) **Int. Cl.**
A63B 53/12 (2006.01)

(73) Assignee: **TRUE TEMPER SPORTS, INC.**,
Memphis, TN (US)

(52) **U.S. Cl.** **473/317**

(21) Appl. No.: **12/940,565**

(57) **ABSTRACT**

(22) Filed: **Nov. 5, 2010**

A golf club includes a tapered shaft, a club head attached to a first end of the shaft, and a grip attached to a second end of the shaft. The exterior surface of the shaft has a surface roughness of less than 143 micro inches. The exterior surface also includes a plurality of particles having a size in the range of about 20 microns to about 100 microns.

Related U.S. Application Data

(60) Provisional application No. 61/262,788, filed on Nov. 19, 2009.

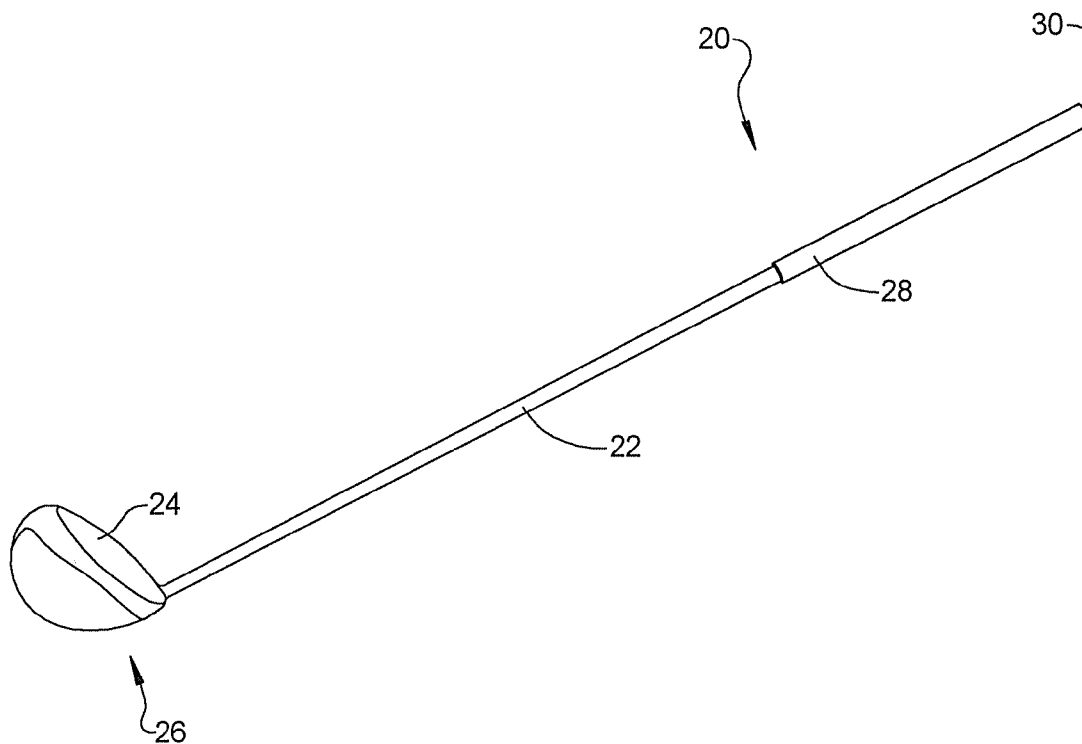

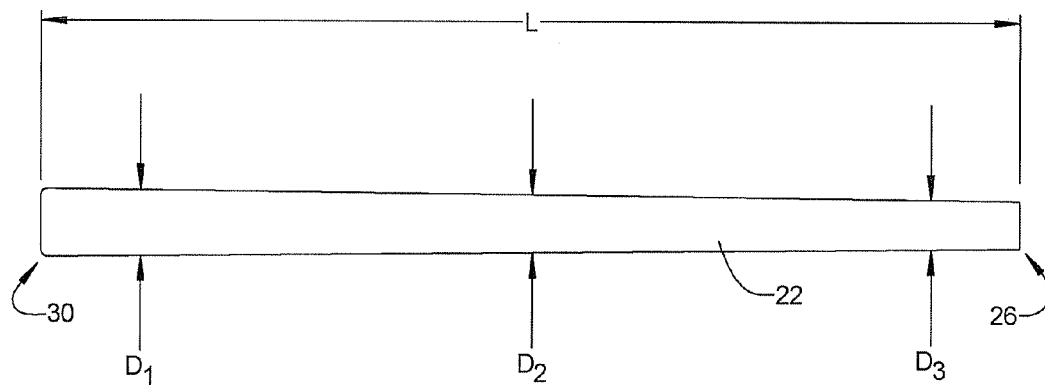
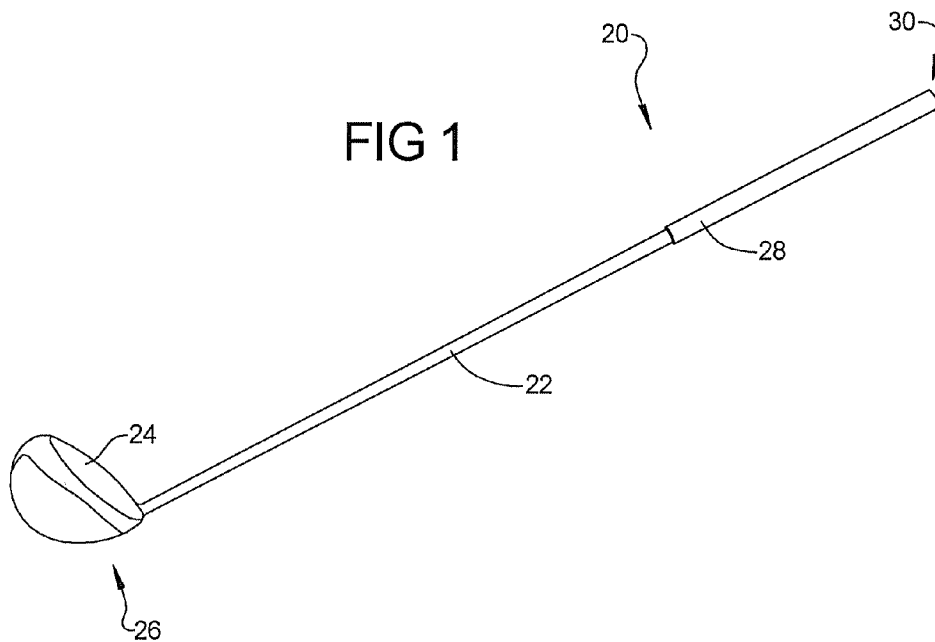

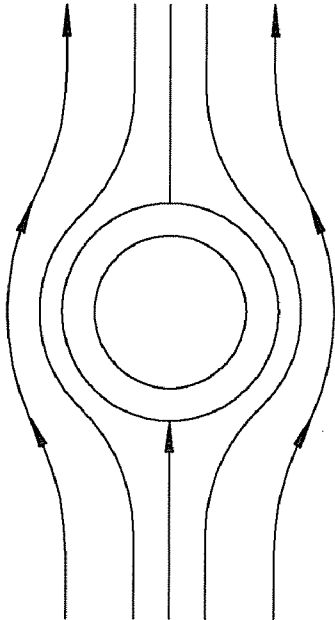

FIG 3

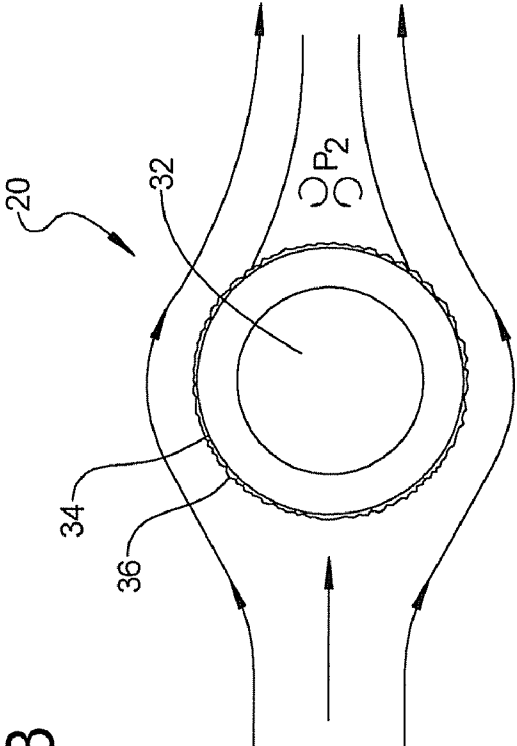

FIG 4

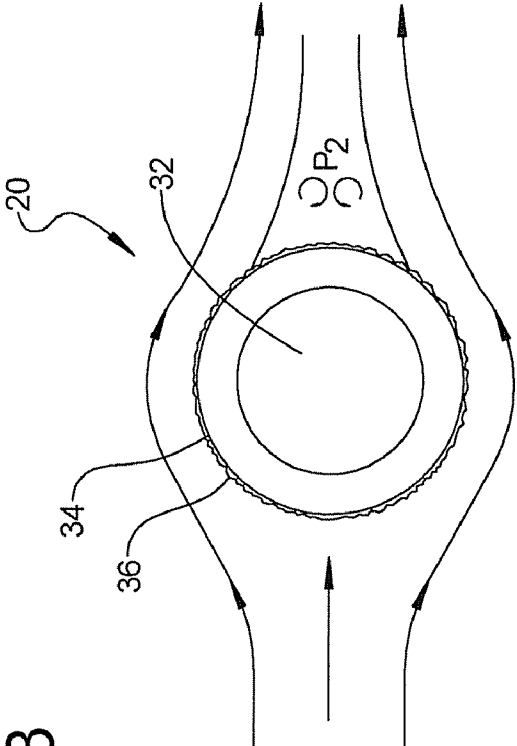
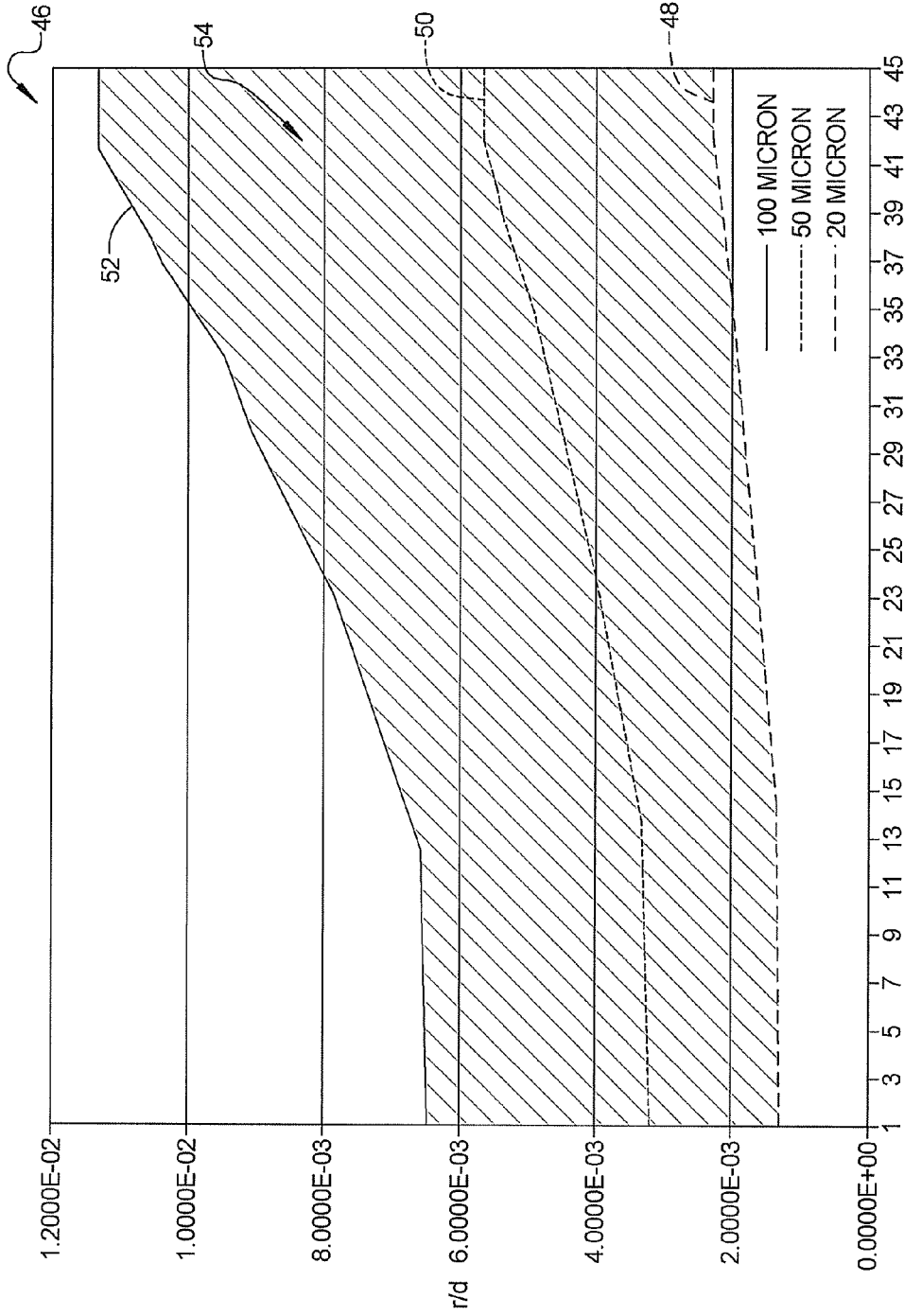

FIG 5



DISTANCE FROM GRIP

FIG 6

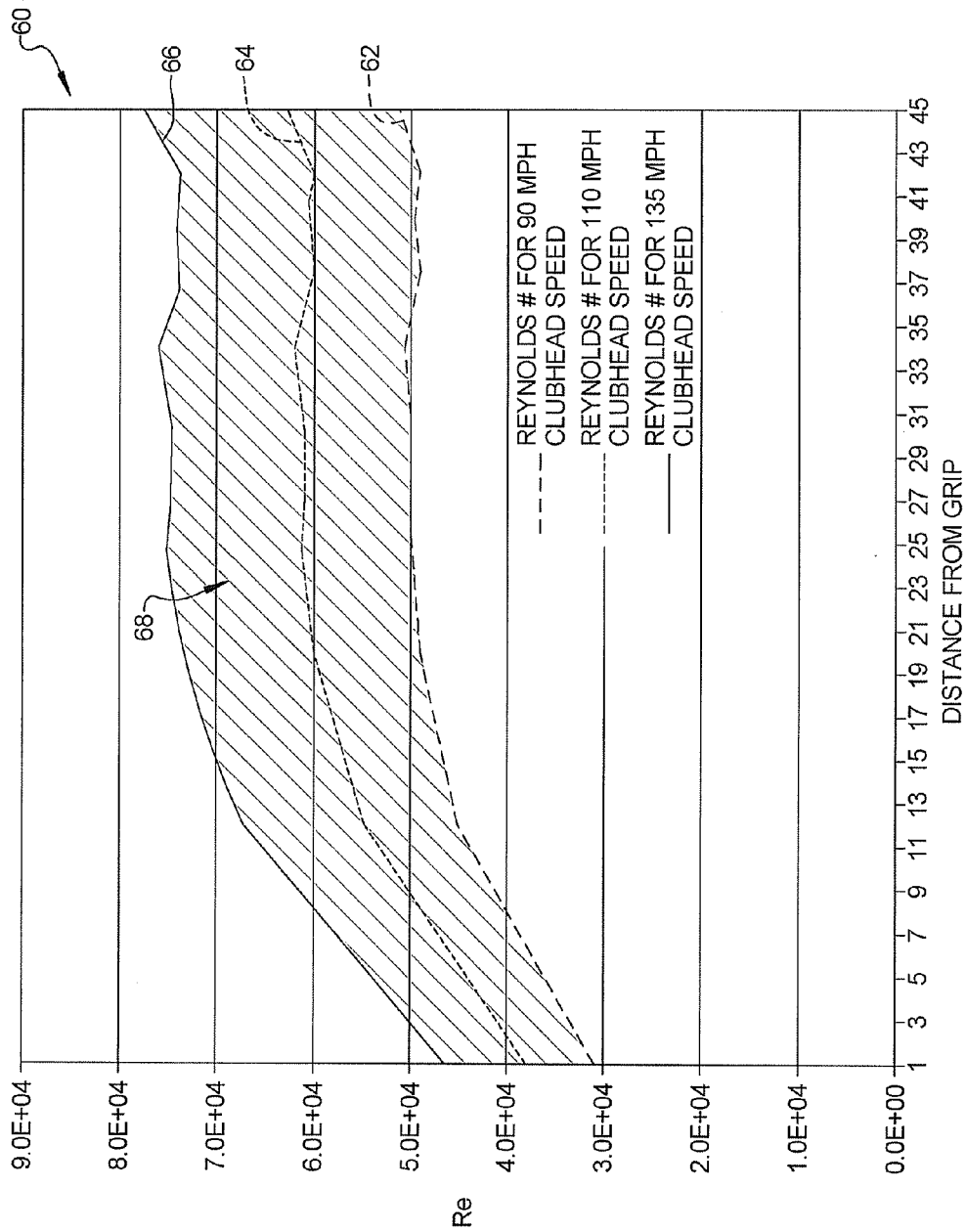

FIG 7

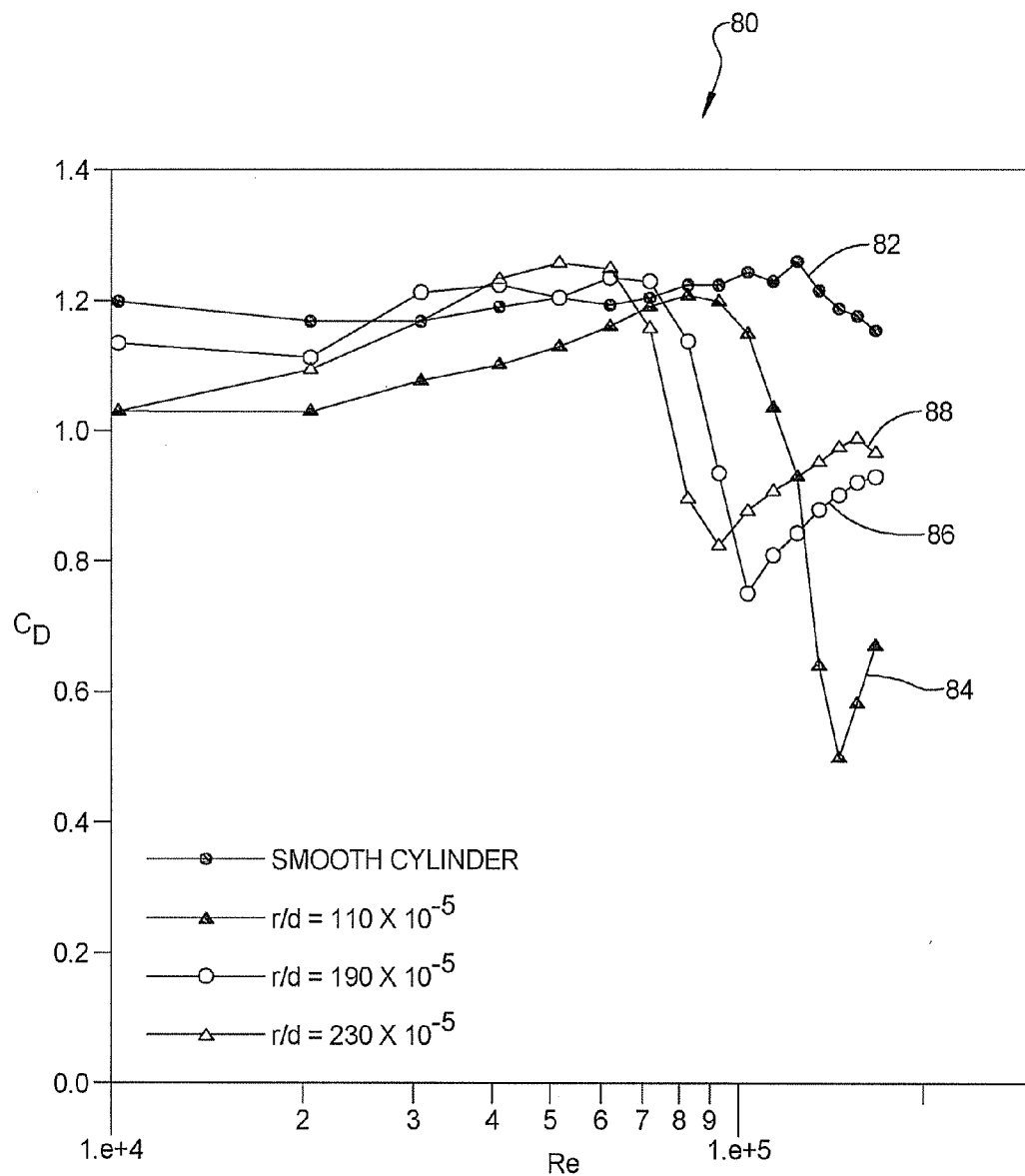

FIG 8

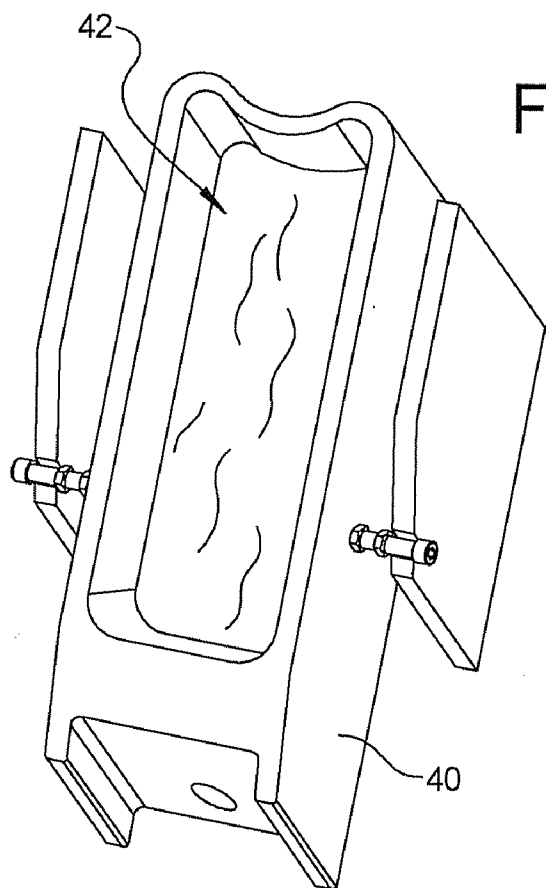

FIG 9

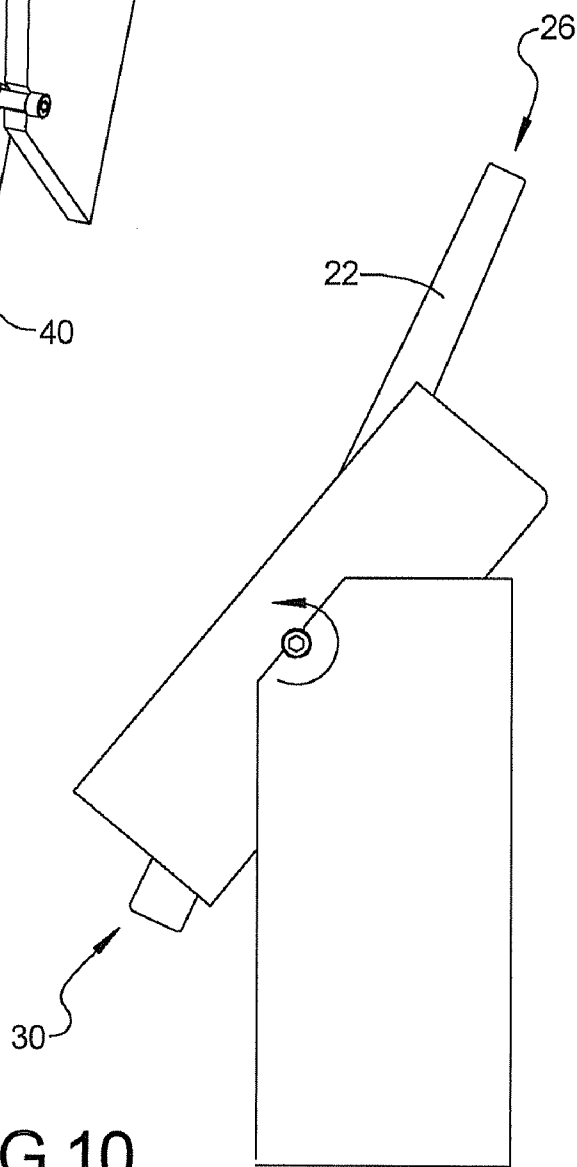

FIG 10

FIG 11

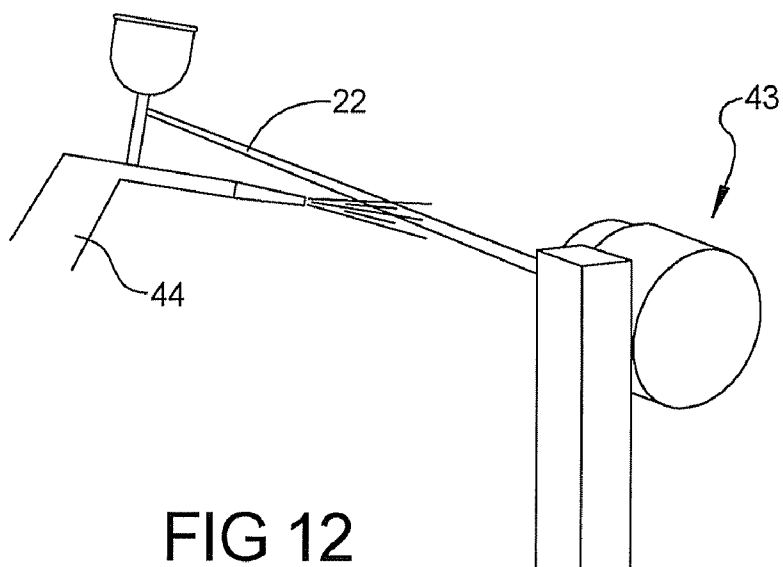
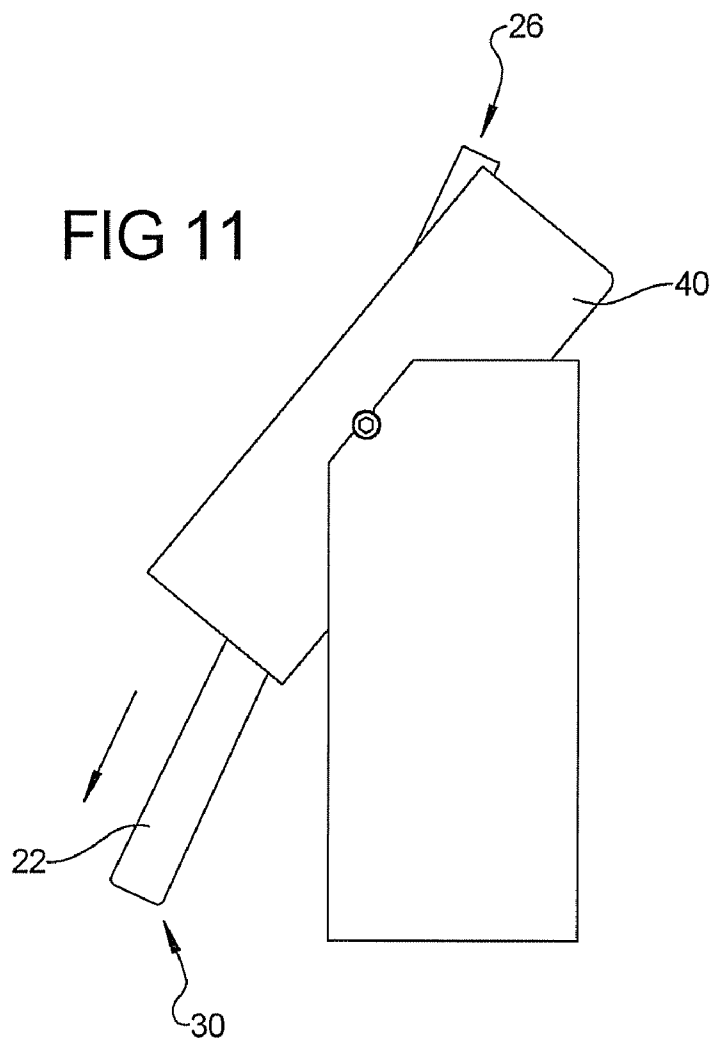

FIG 12

GOLF SHAFT WITH ROUGHENED SURFACE

CROSS-REFERENCE TO RELATED APPLICATION

[0001] This application claims priority to U.S. Provisional Application Ser. No. 61/262,788 filed Nov. 19, 2009. The disclosure of the above application is herein incorporated by reference.

FIELD

[0002] The present disclosure relates to golf shafts and, more particularly, to golf shafts having a roughened surface.

BACKGROUND

[0003] This section provides background information related to the present disclosure which is not necessarily prior art.

[0004] Golf clubs include a golf shaft with a grip on one end and a club head on the other end. The club head speed affects the force that is imparted to a golf ball. The faster the club head speed, the greater the momentum transferred to the ball and the farther the ball can be hit. Hitting the ball farther can provide a competitive advantage. Thus, it would be advantageous to increase the club head speed of a golf club.

SUMMARY

[0005] This section provides a general summary of the disclosure, and is not a comprehensive disclosure of its full scope or all of its features.

[0006] A golf club is provided that includes a tapered shaft, a club head attached to a first end of the shaft, and a grip attached to a second end of the shaft. The exterior surface of the shaft has a surface roughness of less than 143 micro inches. The exterior surface also includes a plurality of particles having a size in the range of about 20 microns to about 100 microns.

[0007] Further areas of applicability will become apparent from the description provided herein. The description and specific examples in this summary are intended for purposes of illustration only and are not intended to limit the scope of the present disclosure.

DRAWINGS

[0008] The drawings described herein are for illustrative purposes only of selected embodiments and not all possible implementations, and are not intended to limit the scope of the present disclosure.

[0009] FIG. 1 is a perspective view of a golf club with a shaft according to the present disclosure;

[0010] FIG. 2 is a plan view of the golf shaft according to the present disclosure;

[0011] FIG. 3 is a cross-sectional view of a golf shaft showing an idealized air flow over the shaft;

[0012] FIG. 4 is a cross-sectional view of a golf shaft showing a hypothetical air flow over the shaft;

[0013] FIG. 5 is a cross-sectional view of the shaft of FIG. 2 showing a hypothetical air flow over the shaft according to the present disclosure;

[0014] FIG. 6 is a graph illustrating various r/d ratios as a function of distance for the shaft of FIG. 2;

[0015] FIG. 7 is a graph of the Reynolds number Re for the shaft of FIG. 2 as a function of distance from the grip end for various club head speeds;

[0016] FIG. 8 is a graph of experimental data showing the drag coefficient C_d as a function of the Reynolds number Re for shafts having various r/d ratios;

[0017] FIGS. 9-11 are schematic views illustrating the manufacture of the shaft of FIG. 2 according to a first method; and

[0018] FIG. 12 is a schematic representation of the manufacture of the shaft of FIG. 2 according to a second method.

[0019] Corresponding reference numerals indicate corresponding parts throughout the several views of the drawings.

DETAILED DESCRIPTION

[0020] Example embodiments will now be described more fully with reference to the accompanying drawings.

[0021] In FIGS. 1 and 2, a golf club 20 having a shaft 22 according to the present disclosure is shown. Golf club 20 includes a club head 24 attached to a first end 26 of shaft 22 and a grip 28 attached to a second end 30 of shaft 22. Second end 30 is also referred to as the grip end. Shaft 22 has a length L between first end 26 and second end 30. Shaft 22 is generally circular in cross-section and may have an outer diameter D that changes along length L. For example, shaft 22 may have a diameter D_1 adjacent first end 26, a diameter D_2 in an intermediate portion of shaft 22, and a diameter D_3 adjacent second end 30 that all have different values. Diameter D_1 may be greater than diameter D_2 , which may be greater than diameter D_3 .

[0022] Referring now to FIG. 5, a cross-sectional view of shaft 22 is shown. Shaft 22 can be made from a variety of materials. By way of non-limiting example, shaft 22 can be a composite, such as graphite, a metal, and the like. Shaft 22 may have a hollow interior cavity 32 and an exterior surface 34. Exterior surface 34 according to the present disclosure is a roughened or textured surface (hereinafter "roughened surface") which provides a reduced aerodynamic drag such that the drag force F_D acting on shaft 22 while swinging through the air is reduced, as described below.

[0023] Exterior surface 34 of shaft 22 may be a roughened surface by applying particles to exterior surface 34. Shaft 22 may include an exterior coating 36 to provide a desired finish or appearance for shaft 22. Exterior coating 36 may be a urethane based coating, by way of non-limiting example. To provide exterior surface 34 with a desired roughness or texture, particles can be added to exterior coating 36. Preferably, particles ranging in size between 20-100 microns are utilized to provide roughened surface 34. The particles may be spherical silica particles, spherical aluminum oxide particles, ceramic particles, and the like by way of non-limiting example. The use of spherical particles may advantageously provide a more consistent surface and improve the ability to create a more precise surface roughness. Depending on the particle size, at least two different application methods may be utilized to apply exterior coating 36 in conjunction with the particles.

[0024] The coating can be prepared by mixing the particles into the coating material to form a solution. Preferably, the particles are mixed into a solution with a viscosity higher than the viscosity at which it will be applied. The mixing of the particles into a solution with a higher viscosity can reduce and/or prevent settling of the particles during the delay between mixing and application. Thinners, such as a solvent,

may be added right before application to improve the flow of the solution for better application on shaft 22. A final surface roughness may be modified in at least two ways. A first way is by varying the size of the particles. A second way is by varying the amount or concentration of particles mixed into the paint solution. As the particle percentage increases, however, the chances of settling or conglomeration may also increase.

[0025] Referring to FIGS. 9-11, a preferred method of applying exterior coating 36 to shaft 22 is illustrated. This method is known as the “Squeegee method” and is used for coating circular cross-sections. This method involves using a rubber disk (not shown) with a smaller diameter hole (smaller than the diameter of shaft 22) to apply a thin layer of paint to shaft 22. A reservoir 40 includes the rubber disk and a cavity 42 to hold the paint solution. The paint and particles are mixed thoroughly and poured into reservoir 40. Shaft 22 is inserted through the rubber disk to about 10 inches from second end 30. Reservoir 40 is then tilted, such as shown in FIG. 10, to coat the rubber disk with the paint/particle solution and shaft 22 is drawn through the rubber disk, such as shown in FIG. 11, at a speed of about 1 ft/sec, by way of non-limiting example. As shaft 22 is drawn through the rubber disk, an approximately 0.002 inch thick layer of paint/particle solution may be applied. The shaft 22 with exterior coating 36 thereon may be allowed to cure at room temperature and/or placed in an oven between 180-200° F., by way non-limiting example, for between 90-120 minutes, by way of non-limiting example, to cure the surface coating 36. The Squeegee method is preferable for particle sizes of 50 microns and under. The Squeegee method may provide for a consistent film thickness and may reduce waste compared to other application methods.

[0026] Referring now to FIG. 12, a second method of applying a paint/particle solution onto shaft 22 is shown. The “spray coating method” comprises high pressure air which vaporizes liquid from a holding chamber, spraying it on exterior surface 34 of shaft 22. Shaft 22 may be held in a chuck 43 rotating about 180 to about 1000 rpm, by way of non-limiting example, so as to distribute the solution evenly around the circumference of shaft 22. The paint and particles are mixed and poured into a media chamber on a spray gun 44. As long as the particles remain about or below 120 microns, a standard spray nozzle may be used. Suitable spray guns and nozzles may include a Sata Mini Jet Model HVLP-3, with 1.3-1.5 mm nozzle size. Another suitable spray gun and nozzle size includes a Speedaire model 4XP65 with a 1.5 mm nozzle size. Using a pressure 50-100 psi, the solution is sprayed on shaft 22 in a sweeping motion along its length while shaft 22 rotates until the exterior surface below the grip area of shaft 22 is evenly covered. Exterior coating 36 is then allowed to sit at room temperature for about 20 minutes to allow volatiles to evaporate before being placed in an oven for curing. The coated shaft 22 may be placed in an oven between about 180-200° F. for between about 90-120 minutes, by way of non-limiting example. This method can be used to apply particles of any size in the previously mentioned range of 20-100 microns.

[0027] Regardless of which method is utilized, a shaft 22 with a tubular shape of tapering diameter ranging between about 0.650 inches and about 0.250 inches with a surface roughness between about 50 and about 150 micro inches Ra may be achieved. In one embodiment, shaft 22 has a varying outer diameter that ranges from about 0.625 inches adjacent second end 30 to about 0.250 inches adjacent first end 26 and

includes an exterior coating 36 with particles of about 50 microns in size. Preferably, shaft 22 has a surface roughness of 143 micro inches or less.

[0028] Referring to FIG. 6, a graph 46 illustrates the r/d ratio for shaft 22 as a function of distance from second end 30 for various particle sizes that are utilized in exterior coating 36. In the r/d ratio, “r” is the diameter of the particle while “d” is the outer diameter of shaft 22. Line 48 represents the r/d ratio of shaft 22 with a particle size of 20 microns. Line 50 represents the r/d ratio of shaft 22 with a particle size of 50 microns. Line 52 represents the r/d ratio of shaft 22 with a particle size of 100 microns. The r/d ratio increases along the length of shaft 22 from second end 30 due to the decreasing outer diameter of shaft 22 as it extends from second end 30 to first end 26.

[0029] As can be seen, the r/d ratio can range from 1.29×10^{-3} adjacent second end 30 to about 2.27×10^{-3} adjacent first end 26 for a particle size of 20 microns. The r/d ratio may also range from about 6.46×10^{-3} adjacent second end 30 to about 11.33×10^{-3} adjacent first end 26. In the embodiment wherein the particle size is 50 microns, the r/d ratio can range from about 3.23×10^{-3} adjacent second end 30 to about 5.66×10^{-3} adjacent first end 26. Thus, the shaft 22 according to the present disclosure may have an r/d ratio along its length in the range shown by the hatched area 54. The surface roughness of exterior surface 34 may reduce the coefficient of drag C_d when shaft 22 is traveling through the air, as described below.

[0030] Referring to FIGS. 3-5, an effect of the surface roughness of exterior surface 34 of shaft 22 on the air flow thereacross is illustrated. In FIG. 3, an idealized flow on a shaft with a smooth exterior surface is shown. In the idealized flow, the air flow is equal on the front side (upstream side) and back side (downstream side) of the shaft creating an even pressure distribution. FIG. 4 shows a hypothetical representation of an actual flow of air on a shaft with a smooth exterior surface. The air flow is unable to remain in contact with the exterior surface of the shaft and creates a low pressure area P_1 on the back side (downstream side) of the shaft. As shown in FIG. 5, the shaft 22 having the roughened exterior surface 34 according to the present disclosure has an air flow that remains in contact with exterior surface 34 for a larger area, thereby forming a low pressure area P_2 on the back side (downstream side) of the shaft that is smaller than the reduced pressure area P_1 of the smooth shaft. The roughened exterior surface 34 enables the air flow to remain in contact with exterior surface 34 for a larger area as it extends around shaft 22. The roughened exterior surface 34 reduces the drag coefficient C_d which thereby functions to reduce the drag force F_d . In particular, the drag force on an object is a function of air density, velocity, characteristic area, and the drag coefficient as shown below in Equation 1.

$$F_d = \frac{1}{2} \rho V^2 A C_d \tag{1}$$

wherein F_d is the drag force, ρ is the density of the air, V is the velocity of the object, A is the characteristic area (diameter) of the shaft, and C_d is the drag coefficient. By reducing the drag coefficient C_d , a reduction in the drag force F_d on the shaft may be realized. In particular, there is a proportional relation between the drag force F_d and the drag coefficient C_d . Therefore, a 10% reduction in the drag coefficient C_d will result in a 10% reduction in the drag force F_d .

[0031] The lower pressure on the back side of the shaft may create a vacuum type effect wherein the lower pressure pulls backwardly on the shaft and opposes the forward movement

of the shaft through the air. By reducing the size of the reduced pressure area on the back side of the shaft, a reduction in the drag force F_d is achieved and an increase in the speed of club head **24** may be realized. An increase in the speed of club head **24** may result in greater momentum transfer to a ball being hit with club **20** and result in a longer distance hit.

[0032] Referring now to FIG. 7, a graph **60** of the Reynolds number Re for an embodiment of shaft **22**, having the r/d ratio associated with a 50 micron particle size, as a function of distance from second end **30** is shown for varying speeds of club head **24**. The Reynolds number Re is a dimensionless number that gives a measure of the ratio of inertial forces to viscous forces and, consequently, it quantifies the relative importance of these two types of forces for given flow conditions. The Reynolds number for shaft **22** can be calculated as shown below in Equation 2.

$$Re = \rho U D / \mu \quad [2]$$

wherein Re is the Reynolds number, ρ is the density of the fluid (air), U is the fluid velocity, which in the instant case is the speed of the club through the air, D is the shaft diameter at the particular position along the length of shaft **22**, and μ is the viscosity of the fluid (air). For the calculations in FIG. 7, the air density ($\rho = 1.21 \text{ kg/m}^3$) and viscosity ($\mu = 18.8 \times 10^{-6} \text{ N s/m}^2$) are for a temperature of approximately 65° F. Thus, the Reynolds number Re will be a function of the speed of shaft **22** through the air along with the diameter of the shaft.

[0033] Line **62** is representative of the Reynolds number Re for a club head speed of 90 mph while line **64** is for a club head speed of 110 mph and line **66** is for a club head speed of 135 mph. As can be seen, the Reynolds number Re increases as a function of club head speed such that line **66** is always above lines **64** and **62** along the entire distance of shaft **22**. As a result, a club **20** having a shaft **22** according to an embodiment may have a Reynolds number Re that ranges from about 3.1×10^4 to about 5.2×10^4 for a club head speed of 90 mph. When the club head speed is 110 mph, the Reynolds number Re may range from about 3.8×10^4 to about 6.3×10^4 . When the club head speed is 135 mph, the Reynolds number Re may range from about 4.7×10^4 to about 7.7×10^4 . Furthermore, it can be seen that Reynolds number Re varies as a function of distance along shaft **22** such that the largest Reynolds number Re is achieved adjacent first end **26** while the lower Reynolds number Re is realized adjacent second end **30**. Moreover, club **20** and shaft **22** according to the embodiment may have a range of Reynolds number Re as indicated in the hatched region **68** which extends between line **62** and line **66** with a club head speed between 90-135 mph.

[0034] Referring now to FIG. 8, a graph **80** of experimental data comparing the coefficient of drag C_d as a function of Reynolds number Re for cylinders having an exterior surface of varying degrees of roughness is shown. Line **82** is for a cylinder having a smooth exterior surface. Line **84** is for a cylinder having an r/d ratio of 110×10^{-5} while line **86** is for a cylinder having an r/d ratio of 190×10^{-5} and line **88** is for a cylinder having an r/d of 230×10^{-5} . As can be seen in FIG. 8, for Reynolds numbers less than about 7×10^4 the drag coefficient C_d for a cylinder having an r/d ratio of about 1.10×10^{-3} is less than that of the other cylinders and, more particularly, is less than that of the smooth cylinder (line **82**). Above a Reynolds number of about 7.0×10^4 , the coefficient of drag C_d for cylinders having a non-smooth surface (represented by lines **84**, **86**, and **88**) drops considerably relative to that of the smooth cylinder (line **82**). The drag coefficient C_d for the

rougher cylinders drops off at a lower Reynolds number Re than that for cylinders having a less rough surface, as shown when looking at line **88** versus lines **86** and **84**. As a result, a cylinder having a roughened surface can have a reduction in the drag coefficient C_d relative to a smooth cylinder.

[0035] Accordingly, a club **20** having a shaft **22** according to the present invention utilizes a roughened exterior surface **34** to reduce the drag coefficient C_d and the resulting drag force F_d on club **20**. The shaft **22** has a decreasing exterior diameter as it extends from second end **30** to first end **26** and, as a result, has an r/d ratio that increases along its length towards club head **24**. The Reynolds number Re for club **20** along its length will vary based upon the speed at which club **20** is swung. The shaft **22** can have a Reynolds number Re that ranges between 3.1×10^4 to about 7.7×10^4 for club head speeds between 90 mph to 135 mph. The larger Reynolds number can provide a significant advantage with a roughened exterior surface **34** whereby a reduction in the drag coefficient C_d may be realized. Accordingly, a club **20** utilizing a shaft **22** according to the present disclosure can advantageously incorporate a textured or roughened exterior surface **34** to reduce the drag force F_d imparted on club **20** when being swung. The reduction in the drag force F_d may result in a greater speed of club head **24** and transfer greater force to a struck ball and increase its distance travelled.

[0036] While club **20** and shaft **22** have been described with reference to specific embodiments, it should be appreciated that changes to shaft **22** and/or club **20** may be incorporated. For example, the particles, while being described as spherical silica particles may be made of different materials or have differing shapes to provide a desired roughness for exterior surface **34**. Moreover, while the particles are described as being applied in conjunction with exterior coating **36**, it should be appreciated that other methods for applying particles to the exterior surface **34** may be employed. By way of non-limiting example, an adhesive may be applied to the particles and the particles then applied to exterior surface **34**, although this may require an additional production step. Moreover, it should be appreciated that the shaft **22** and/or club **20** may achieve different r/d ratios and Reynolds numbers than those described herein which can affect the resulting coefficient of drag C_d and drag force F_d .

[0037] The foregoing description of the embodiments has been provided for purposes of illustration and description. It is not intended to be exhaustive or to limit the invention. Individual elements or features of a particular embodiment are generally not limited to that particular embodiment, but, where applicable, are interchangeable and can be used in a selected embodiment, even if not specifically shown or described. The same may also be varied in many ways. Such variations are not to be regarded as a departure from the invention, and all such modifications are intended to be included within the scope of the invention.

What is claimed is:

1. A golf club comprising:

- a shaft having first and second ends and an exterior surface, said shaft having an outer diameter that diminishes as said shaft extends from said second end to said first end;
 - a club head attached to said first end of said shaft; and
 - a grip attached to said second end of said shaft,
- wherein said exterior surface has a surface roughness of less than 143 micro inches and includes a plurality of particles having a size in the range of about 20 microns to about 100 microns.

2. The golf club of claim 1, wherein said shaft has a r/d ratio in a range of about 1.29×10^{-3} to about 11.33×10^{-3} , wherein "r" is particle diameter and "d" is shaft outer diameter.

3. The golf club of claim 2, wherein said r/d ratio is in a range of about 3.23×10^{-3} to about 5.66×10^{-3} .

4. The golf club of claim 3, wherein the particles have a size of about 50 microns.

5. The golf club of claim 3, wherein the particles have a size of about 20 microns.

6. The golf club of claim 1, further comprising a coating on said exterior surface and wherein said particles are integral with said coating.

* * * * *