



US 20110081984A1

(19) **United States**  
(12) **Patent Application Publication**  
**Beach et al.**

(10) **Pub. No.: US 2011/0081984 A1**  
(43) **Pub. Date: Apr. 7, 2011**

(54) **GOLF CLUB SHAFT**

**Publication Classification**

(75) Inventors: **Todd P. Beach**, San Diego, CA (US); **Drew T. DeShiell**, Oceanside, CA (US); **John Francis Lorentzen**, El Cajon, CA (US)

(51) **Int. Cl.** *A63B 53/16* (2006.01)  
(52) **U.S. Cl.** ..... **473/296**

(73) Assignee: **Taylor Made Golf Company, Inc.**

(57) **ABSTRACT**

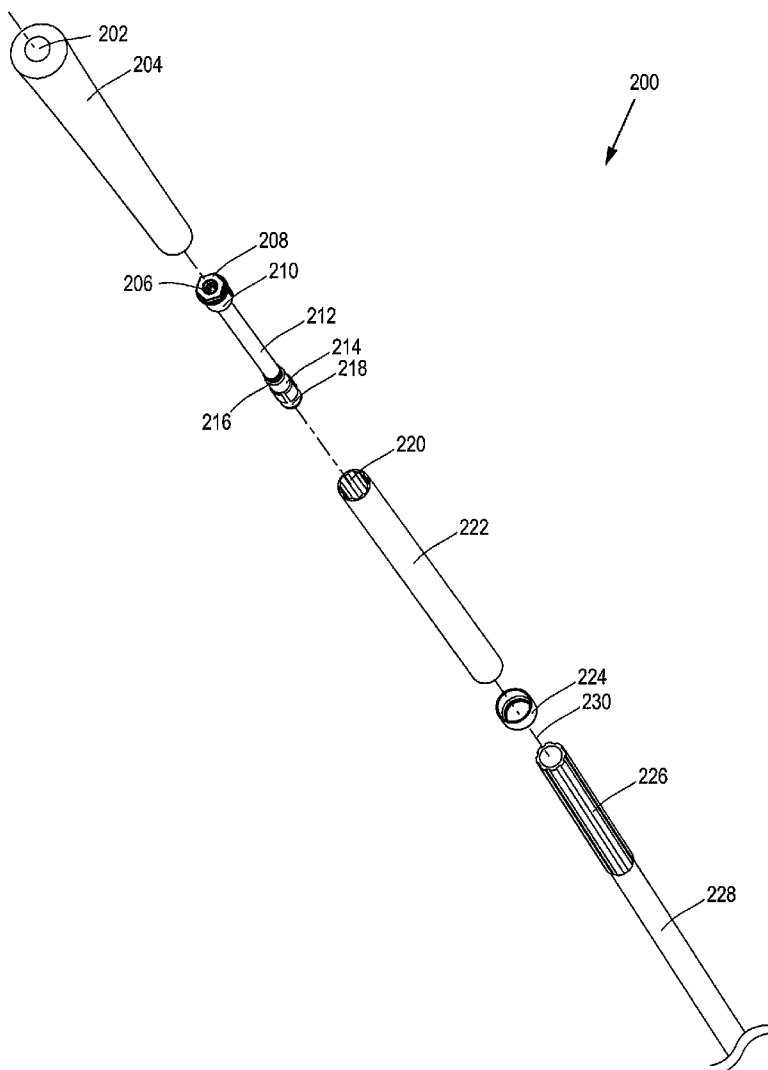
(21) Appl. No.: **12/887,762**

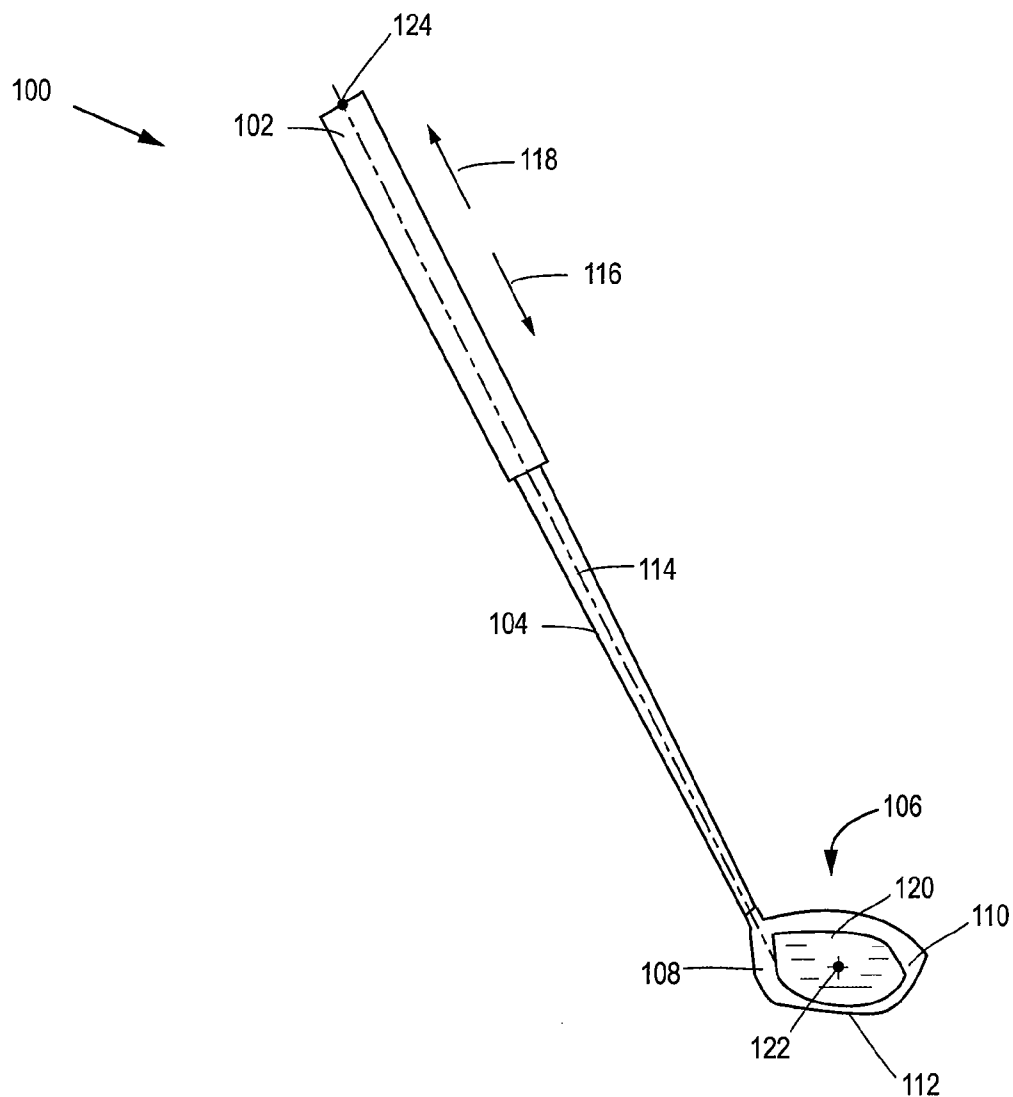
An adjustable length golf club shaft having a grip portion with an end point is disclosed. A locking element is located within the grip portion and a lower shaft having an inner surface that is in frictional contact with the locking element is also disclosed. The locking element is configured to engage the inner surface of the lower shaft. A total length of the golf club shaft is adjustable by a distance of at least one inch and a total weight of the golf club shaft in a weight zone is less than 110 g. The weight zone is defined as a region of the golf club shaft extending from the end point of the grip portion up to 11" along a central axis of the golf club shaft toward a tip portion of the shaft.

(22) Filed: **Sep. 22, 2010**

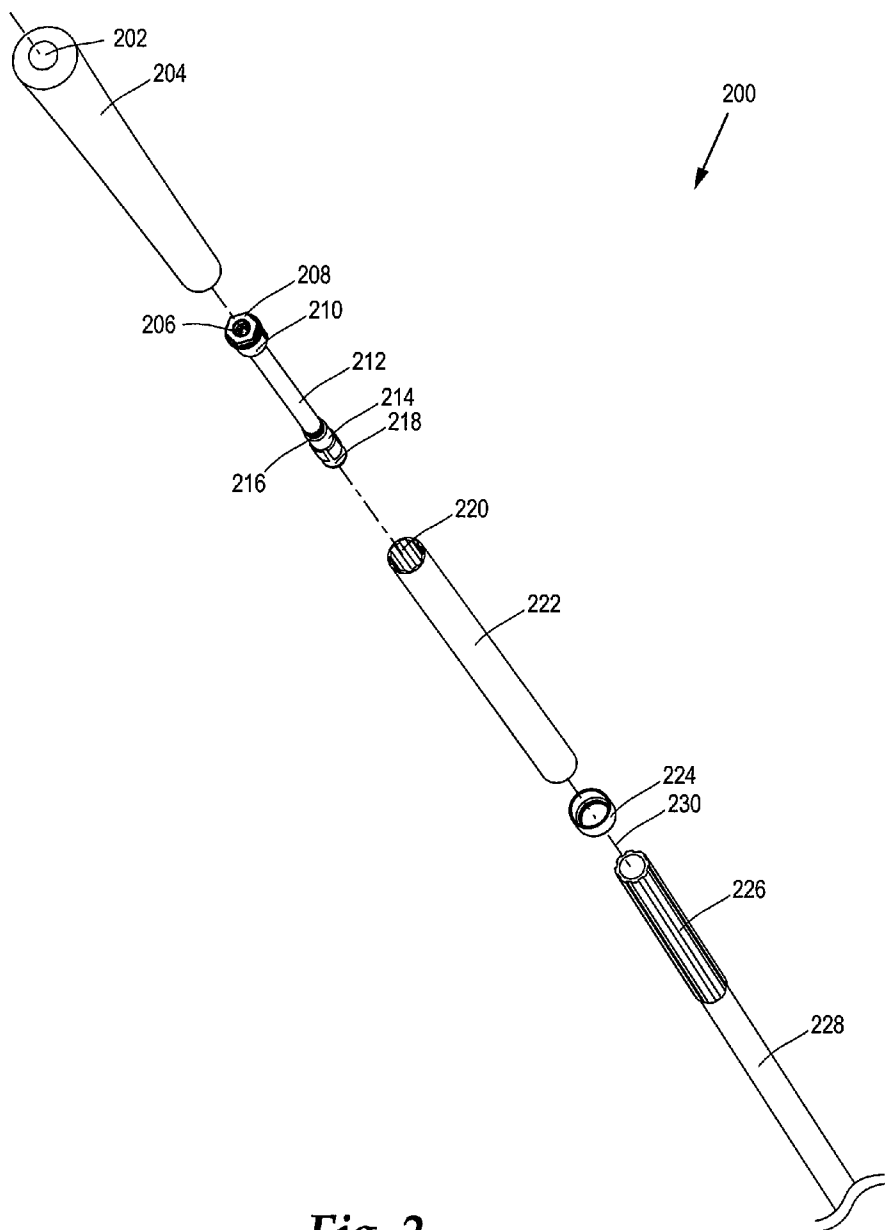
**Related U.S. Application Data**

(60) Provisional application No. 61/278,536, filed on Oct. 7, 2009.





*Fig. 1*



*Fig. 2*

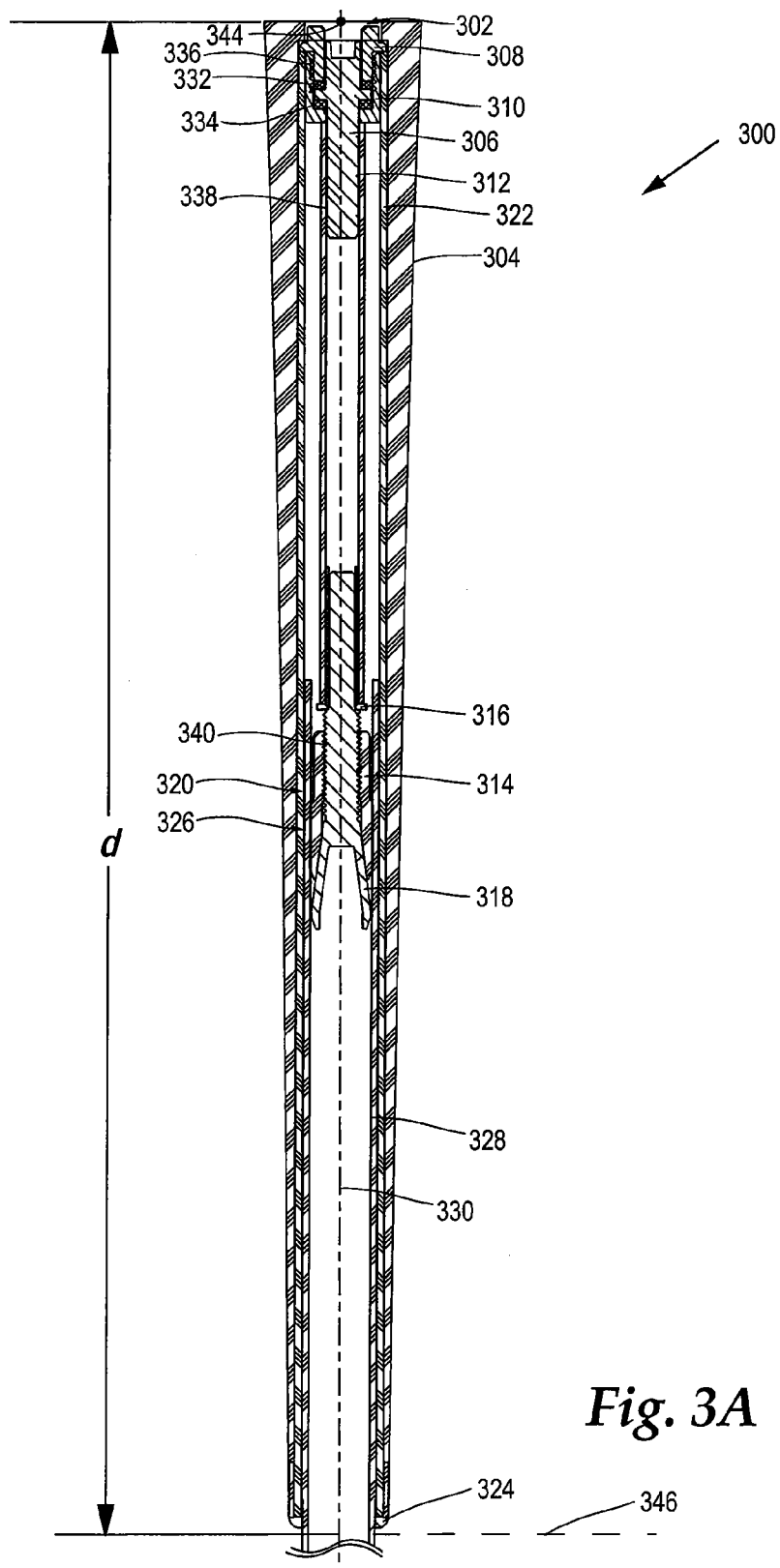
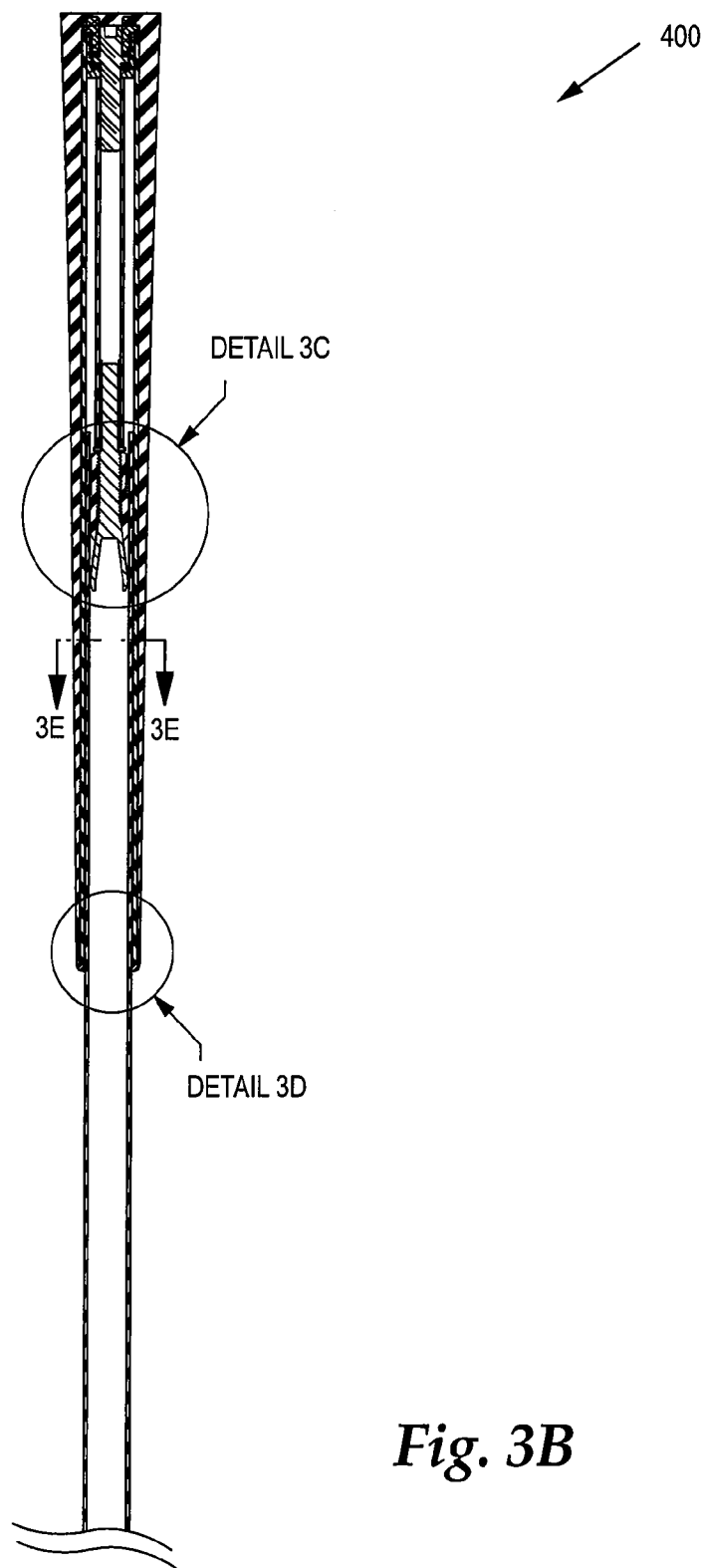
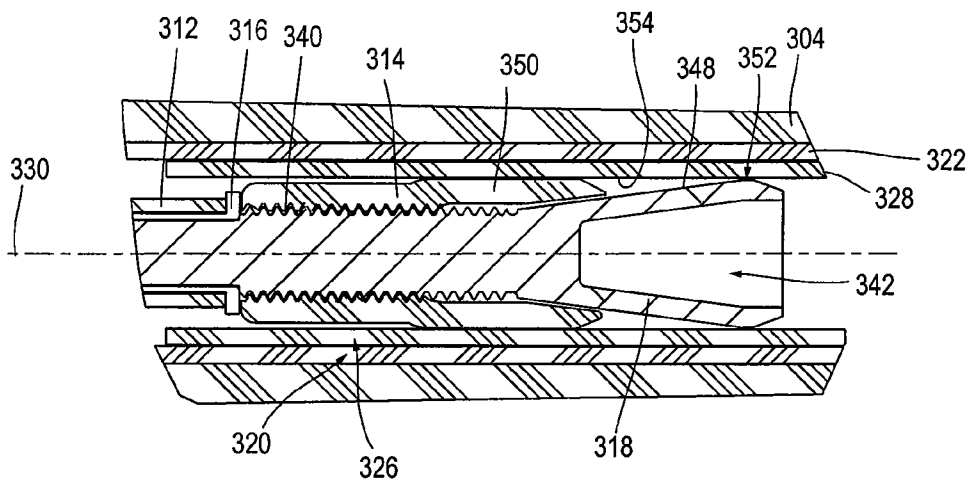


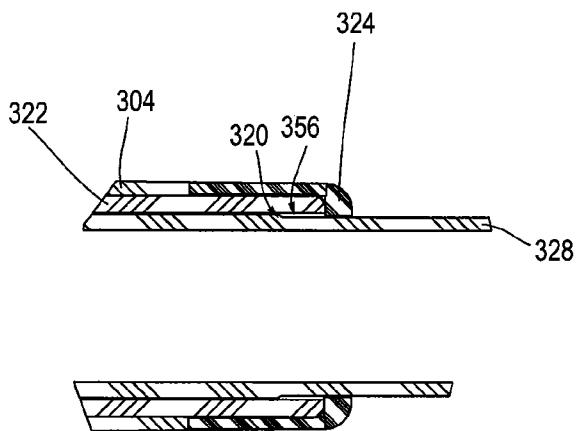
Fig. 3A



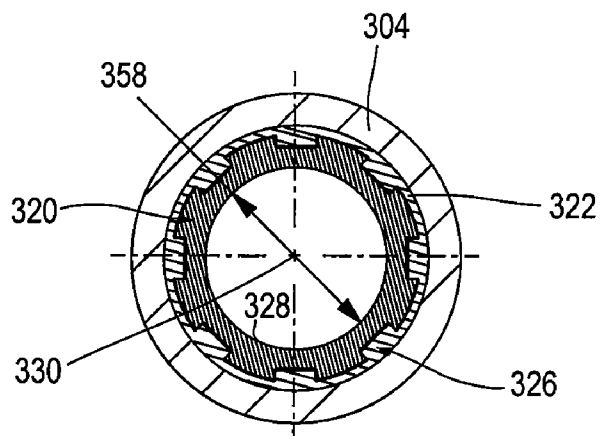
*Fig. 3B*



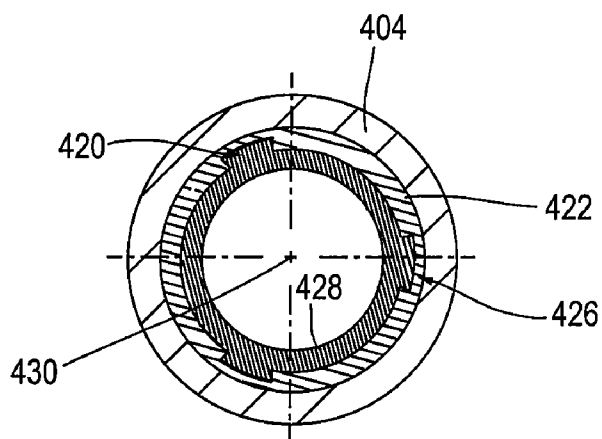
*Fig. 3C*



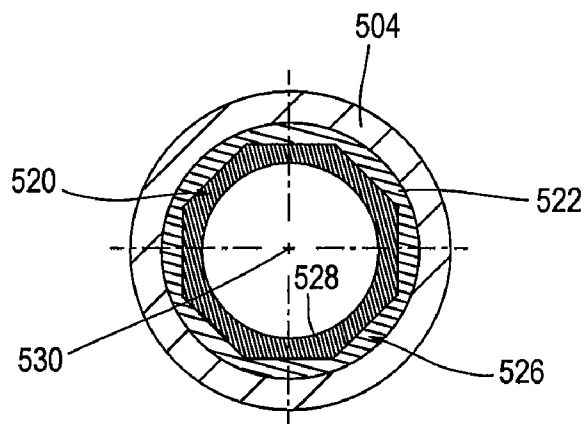
*Fig. 3D*



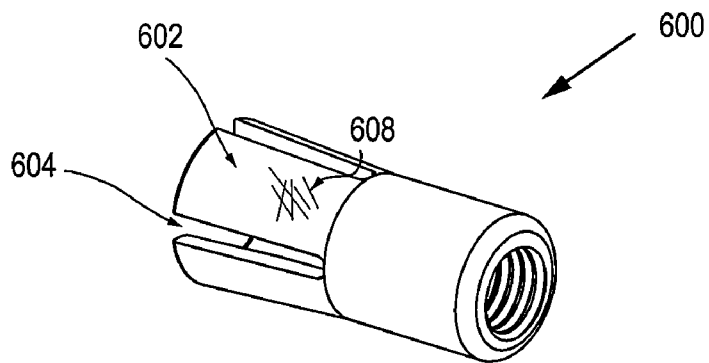
*Fig. 3E*



*Fig. 4*

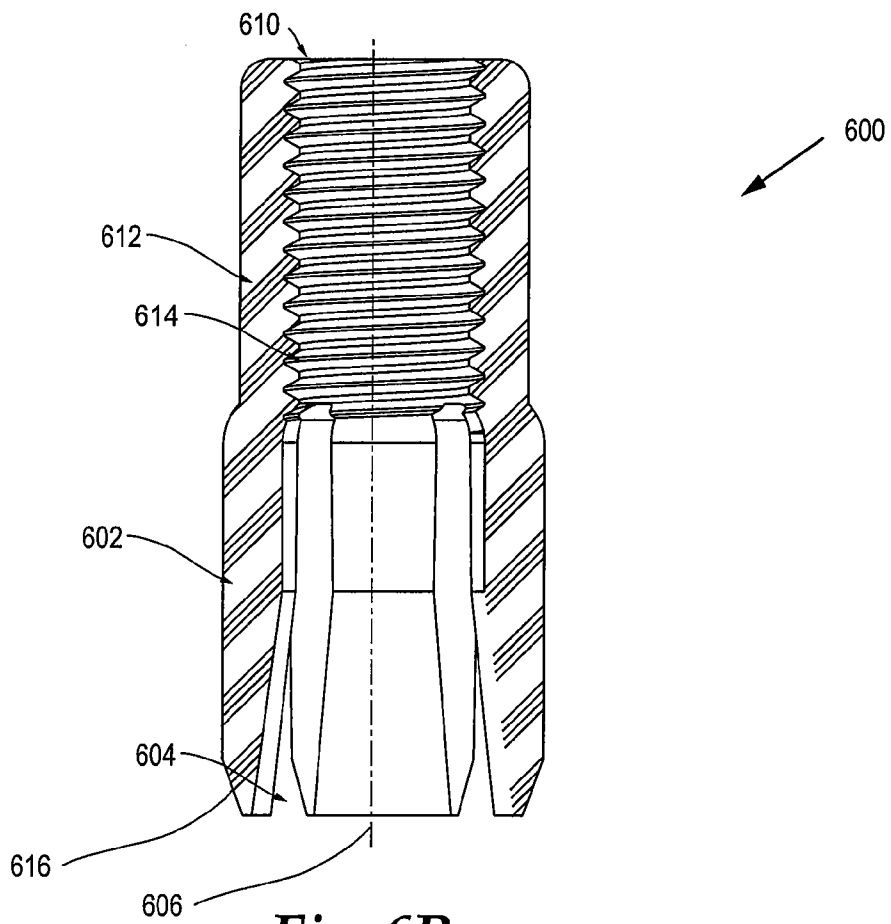


*Fig. 5*

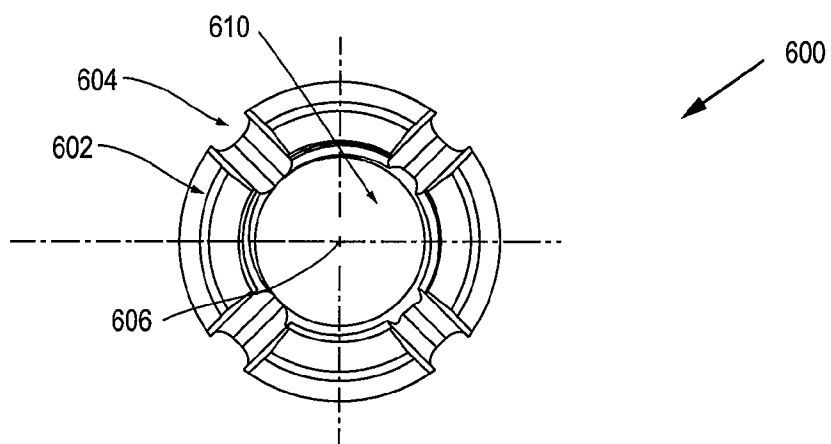


*Fig. 6A*

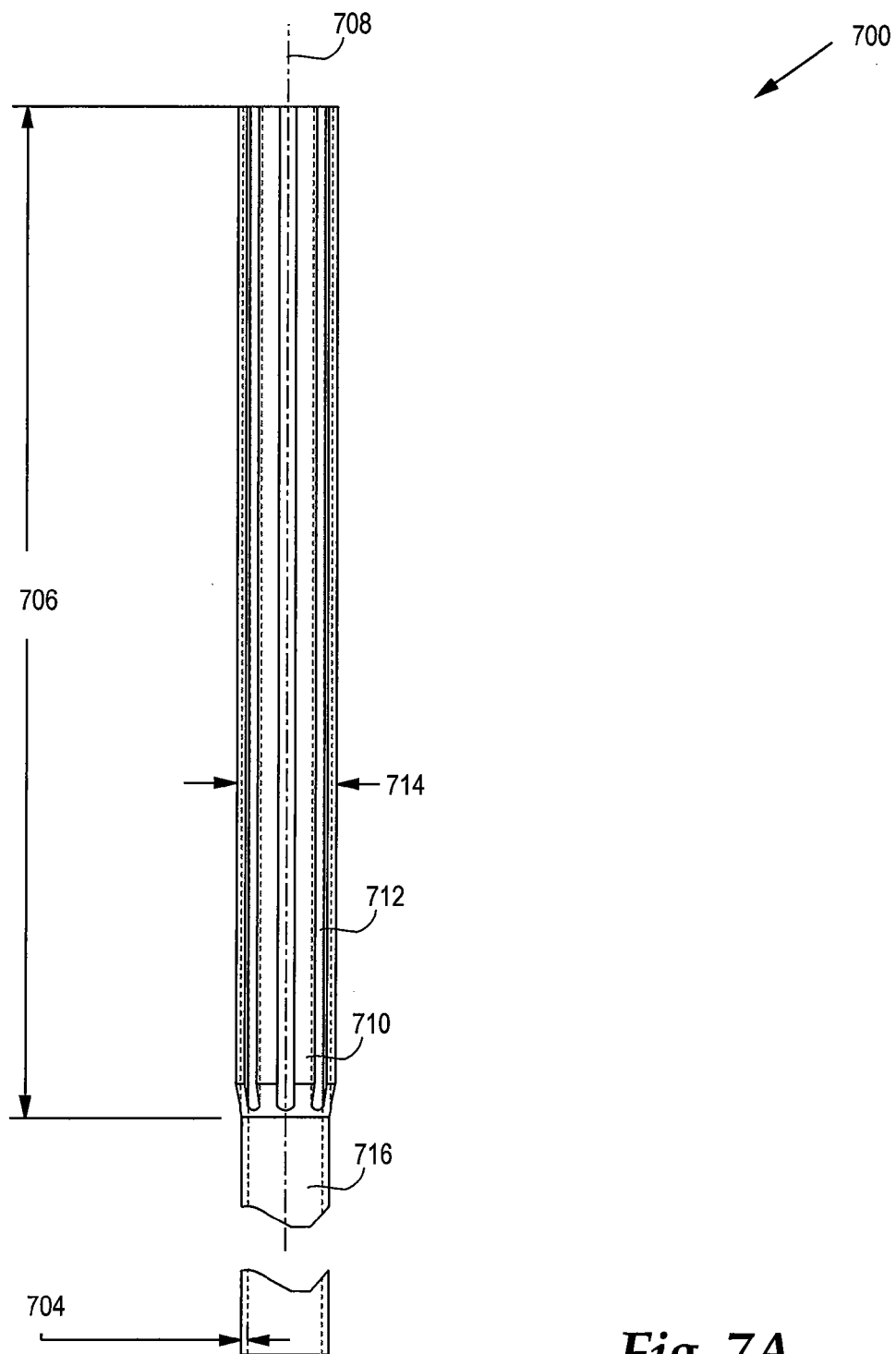




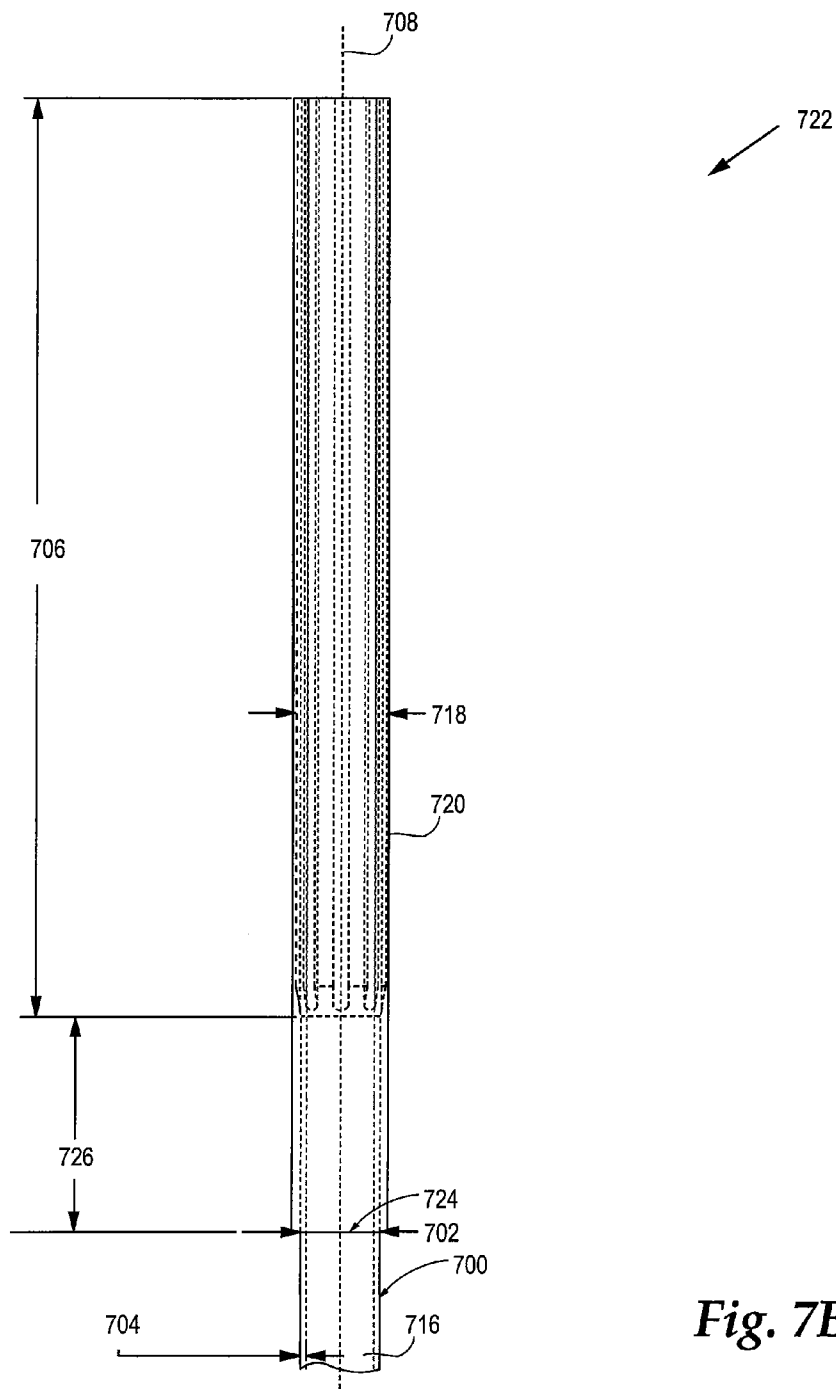
*Fig. 6B*



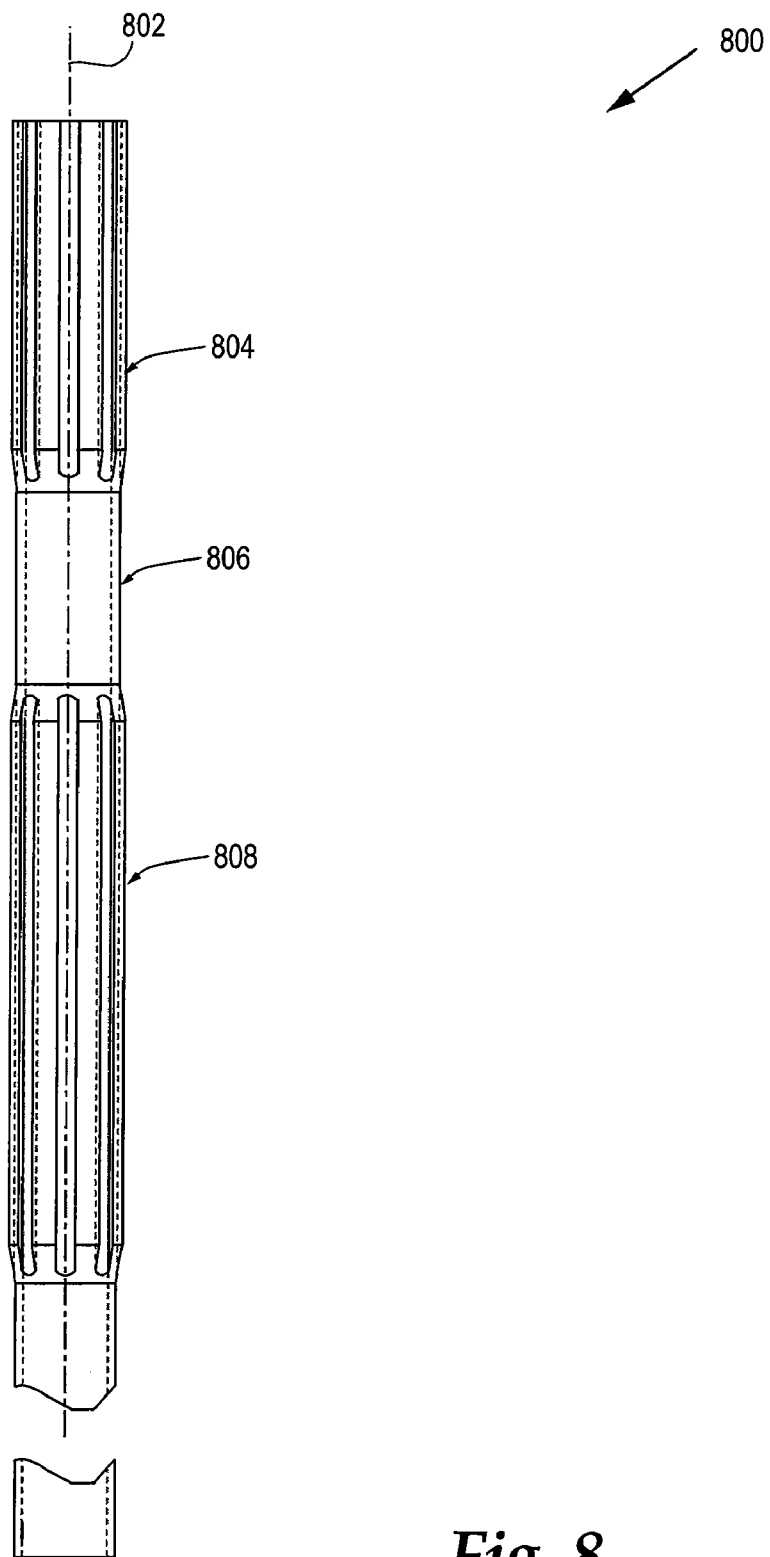
*Fig. 6C*



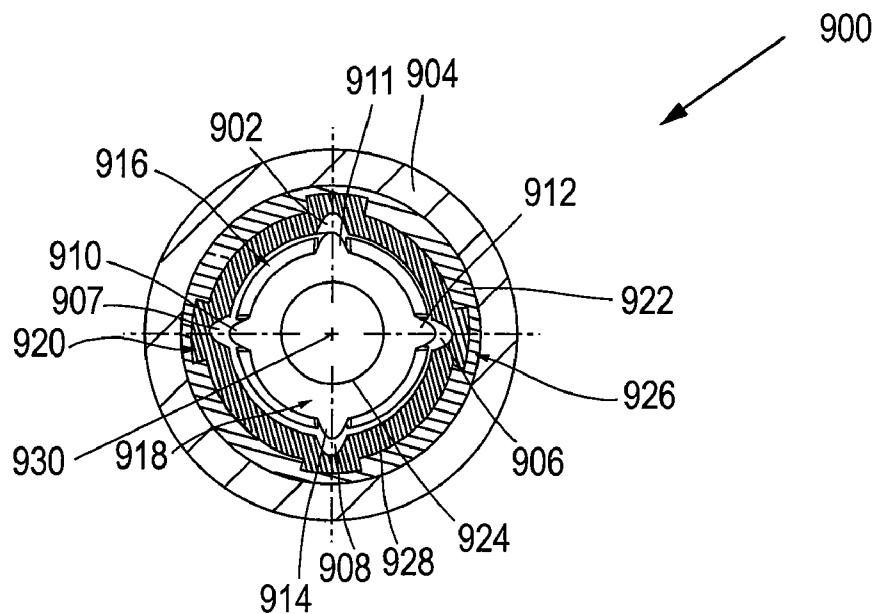
*Fig. 7A*



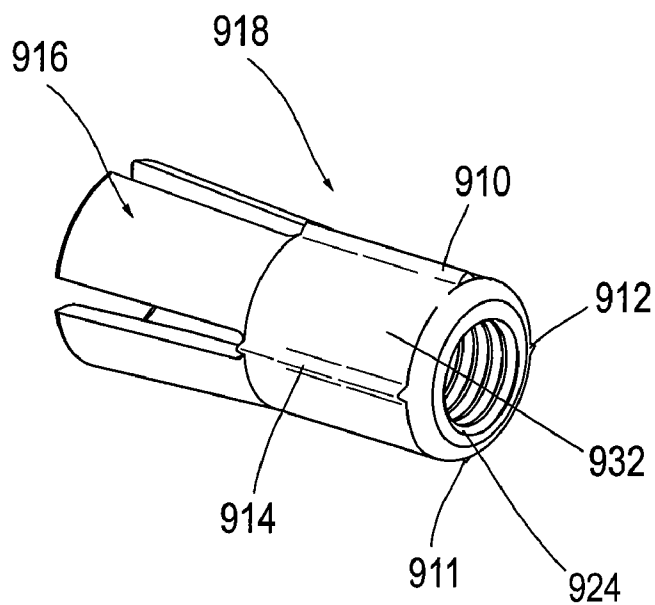
**Fig. 7B**



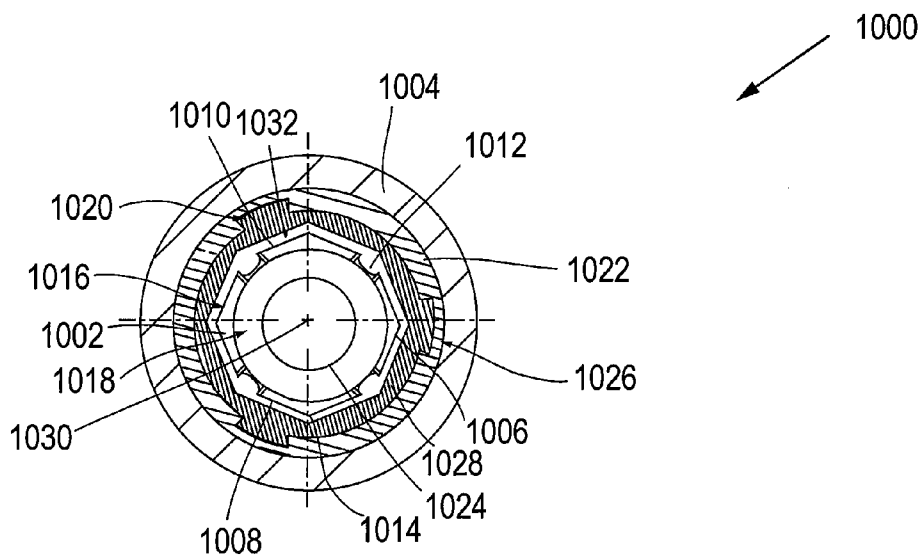
*Fig. 8*



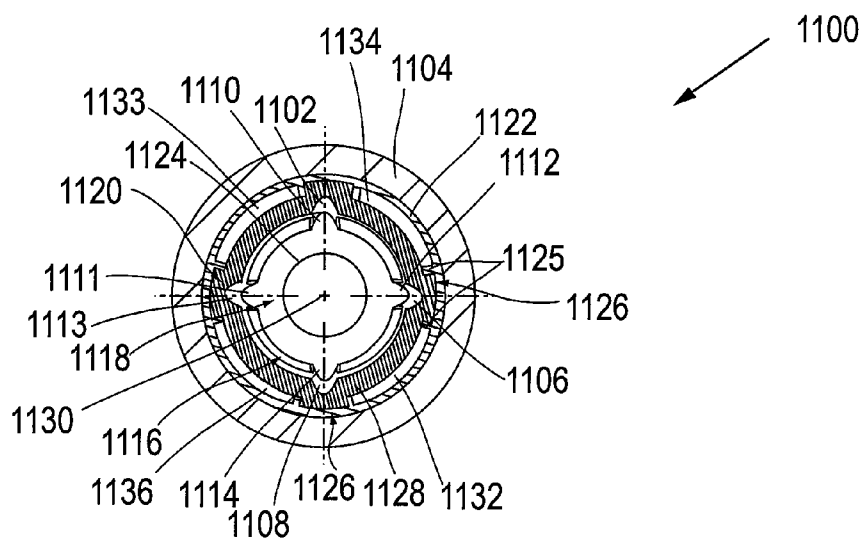
**Fig. 9A**



**Fig. 9B**



**Fig. 10**



**Fig. 11**

## GOLF CLUB SHAFT

### CROSS REFERENCE TO RELATED APPLICATION

**[0001]** This application is a non-provisional application claiming priority to and benefit of U.S. Provisional Patent Application No. 61/278,536, filed Oct. 7, 2009, which is incorporated herein by reference.

### FIELD

**[0002]** The present disclosure relates to a golf club shaft. More specifically, the present disclosure relates to an adjustable golf club shaft.

### BACKGROUND

**[0003]** Golf is a game in which a player, using many types of clubs, hits a ball into each hole on a golf course in the lowest possible number of strokes. A metal wood is typically used at a tee box to strike the ball a long distance.

**[0004]** Typical metal wood shafts are a fixed length and cannot be adjusted. A grip on a typical metal wood shaft is stationary with respect to the club head and a user would need to cut the shaft to make it shorter or purchase another shaft to increase the length.

### SUMMARY OF THE DESCRIPTION

**[0005]** In one embodiment, the present disclosure describes a golf club head comprising a heel portion, a toe portion, a crown, a sole, and a face.

**[0006]** According to one aspect of the present invention, an adjustable length golf club is provided having an engaging mechanism, a drive shaft, a locking element, and a lower shaft. The drive shaft is connected with the engaging mechanism and is configured to rotate upon movement by the engaging mechanism.

**[0007]** In one example of the present invention, an adjustable length golf club shaft is described including a grip portion. The grip portion has an end region including an end point. A locking element located within the grip portion is also described. A lower shaft having an inner surface is in frictional contact with the locking element. The locking element is configured to engage the inner surface of the lower shaft. A total length of the golf club shaft is adjustable by a distance of at least one inch and a total weight of the golf club shaft in a weight zone is less than 110 g. The weight zone is defined as a region of the golf club shaft extending from the end point of the grip portion to 11" along a central axis of the golf club shaft toward a tip portion of the shaft.

**[0008]** The grip portion is adjustable with respect to the lower shaft and a stop prevents the lower shaft from being completely removed from the grip portion. The total length of the golf club shaft is adjustable by a distance of at least 2 inches, 3 inches, or 4 inches.

**[0009]** The total weight of the golf club shaft in the weight zone is less than 85 g, less than 75 g, less than 65 g, or less than 55 g.

**[0010]** In yet another example, the locking element prevents any axial movement between the grip portion and the lower shaft during an axial load of at least 2000 N.

**[0011]** In another example, a first keying feature portion is symmetrical about the central axis. The first keying portion

can include at least one spline or three splines. The at least one first keying portion can include at least two keying regions along the lower shaft.

**[0012]** In one example, the grip portion includes at least one second keying feature portion configured to engage with the at least one first keying feature portion.

**[0013]** In yet another example, the total golf club length is between about 40" and about 48". The grip portion includes an upper shaft portion having an outside diameter of less than 0.700" and the lower shaft includes an outside diameter of greater than 0.450".

**[0014]** In one example, the grip portion includes an upper shaft portion having an outside diameter of less than 0.650" and the lower shaft includes an outside diameter of greater than 0.500".

**[0015]** According to one aspect of the present invention, an adjustable length golf club shaft is described having a lower portion and a grip portion connected with an engaging mechanism and a grip portion connected with the engaging mechanism. The grip portion includes an upper shaft portion having an outside diameter of less than 0.700". A shaft is connected with the engaging mechanism and is configured to rotate upon movement by the engaging mechanism. A locking element is connected with the shaft. The locking element includes at least one locking insert and at least one locking collar located on the at least one locking insert. The at least one locking insert is configured to engage the at least one locking collar during axial movement. A lower shaft having an inner surface that is in frictional contact with the at least one locking collar is described. The lower shaft includes an outside diameter of greater than 0.450". A first rotational movement in a first rotational direction by the shaft causes the at least one locking insert to engage the at least one locking collar creating a frictional locking engagement between the at least one locking collar and the inner surface of the lower shaft.

**[0016]** In yet another embodiment, the total length of the golf club shaft is adjustable by a distance of at least one inch and a total weight of the golf club shaft within a weight zone is less than 110 g. The weight zone is defined as a region of the golf club shaft extending from the end point of the grip portion to 11" along a central axis of the golf club shaft. A lower shaft having an inner surface that is in frictional contact with the locking element is described. A first rotational movement in a first rotational direction by the shaft causes the locking element to engage the inner surface of the lower shaft and a second rotational movement in a second rotational direction by the shaft causes the locking element to disengage from the inner surface of the lower shaft.

**[0017]** The foregoing and other objects, features, and advantages of the invention will become more apparent from the following detailed description, which proceeds with reference to the accompanying figures.

### BRIEF DESCRIPTION OF THE DRAWINGS

**[0018]** The present invention is illustrated by way of example and not limitation in the figures of the accompanying drawings in which like references indicate similar elements.

**[0019]** FIG. 1 is an illustration of an embodiment of a golf club according to the present disclosure.

**[0020]** FIG. 2 is an exploded assembly view of an adjustable shaft according to a first embodiment.

**[0021]** FIG. 3A is a cross-sectional assembled view of an adjustable shaft in a locked position.

[0022] FIG. 3B is a cross-sectional assembled view of an adjustable shaft in an unlocked position.

[0023] FIG. 3C is a detailed cross-sectional view of a locking element taken from FIG. 3B.

[0024] FIG. 3D is a detailed view of a stop taken from FIG. 3B.

[0025] FIG. 3E is a cross-sectional view taken along cross-sectional lines 3E-3E in FIG. 3B.

[0026] FIG. 4 illustrates a cross-sectional view according to another embodiment.

[0027] FIG. 5 illustrates a cross-sectional view according to another embodiment.

[0028] FIG. 6A illustrates an isometric view of a locking element according to one embodiment.

[0029] FIG. 6B illustrates a cross-sectional view of a locking element.

[0030] FIG. 6C illustrates a bottom view of a locking element.

[0031] FIG. 7A illustrates a lower shaft having a keying portion.

[0032] FIG. 7B illustrates a lower shaft assembled with an upper shaft.

[0033] FIG. 8 illustrates a lower shaft with multiple keying portions.

[0034] FIG. 9A illustrates a cross-sectional assembly view according to another embodiment.

[0035] FIG. 9B illustrates an isometric view of a locking element, according to another embodiment.

[0036] FIG. 10 illustrates a cross-sectional assembly view according to another embodiment.

[0037] FIG. 11 illustrates a cross-sectional assembly view according to another embodiment.

#### DETAILED DESCRIPTION

[0038] Various embodiments and aspects of the inventions will be described with reference to details discussed below, and the accompanying drawings will illustrate the various embodiments. The following description and drawings are illustrative of the invention and are not to be construed as limiting the invention. Numerous specific details are described to provide a thorough understanding of various embodiments of the present invention. However, in certain instances, well-known or conventional details are not described in order to provide a concise discussion of embodiments of the present inventions.

[0039] FIG. 1 illustrates a golf club 100 comprising a grip portion 102, a lower shaft 104, and a club head 106. In the embodiment shown in FIG. 1, the golf club 100 is a metal wood-type club head, although the adjustable shaft described herein can be applied to any type of golf club including putters and irons. The club head 106 includes a heel 108, a toe 110, and a sole 112. The lower shaft 104 includes a centerline axis 114 that extends along the entire length and axial centerline of the golf club 100 shaft. A first axial direction 116 is shown to be extending in a direction toward the club head 106 and parallel with the shaft axis 114. In addition, FIG. 1 further shows a second axial direction 118 extending in a direction away from the club head 106 and opposite to the direction of the first axial direction 116. The second axial direction 118 is also parallel with the shaft axis 114. The golf club 100 further includes an endpoint 124 which is the farthest most point along the centerline axis 114 away from the club head 106.

[0040] The club head 106 includes a face portion 120 and a center face point 122 defined as the geometric center of the

face portion 120. The center face point 122 is defined according to USGA "Procedure for Measuring the Flexibility of a Golf Clubhead," Revision 2.0, Mar. 25, 2005.

[0041] FIG. 2 illustrates an exploded assembly view of an exemplary adjustable golf club shaft 200, according to one embodiment. The adjustable golf club shaft 200 includes a grip cover 204, a grip end opening 202, an upper housing portion 208, a lower housing portion 210, a drive bolt 206, a drive shaft 212, a stop 216, a locking element 214 or mechanism, a plug 218, an upper shaft 222, an upper shaft keying portion 220, a stop 224, a lower shaft 228, a lower shaft keying portion 226, and a centerline axis 230. The grip cover 204 (being a molded grip) and upper shaft 222 are herein referred to as a "grip portion."

[0042] FIG. 3A shows an assembled cross-sectional view of the adjustable golf club shaft 300 similar to the shaft as shown in FIG. 2. The grip cover 304 envelops an external surface of the upper shaft 322. The upper shaft 322 is coaxially aligned with the lower shaft 328 about the centerline axis 330. The upper shaft 322 and the lower shaft 328 have an overlapping region where the upper shaft 322 telescopically receives the lower shaft 328. The lower shaft 328 is slidably engaged with the upper shaft 322 so that the length of the lower shaft 328 is adjustable with respect to the upper shaft 322. However, an engaged keying region 320 allows the keying portion of the lower shaft 328 to engage with the keying portion of the upper shaft 322 to prevent rotation of the upper shaft about the lower shaft, as will be shown in further detail below.

[0043] In one embodiment, the upper shaft 322 is a graphite or carbon composite material while the lower shaft 328 is also a graphite or composite material. The lightweight construction of the upper shaft 322 and lower shaft 328 allows the weight of the adjustable club to be below a weight threshold.

[0044] FIG. 3A illustrates a grip cover 304, a grip end opening 302, an upper housing portion 308, a lower housing portion 310, a drive bolt 306, a drive shaft 312, a stop 316, a locking element 314, a plug 318, an upper shaft 322, an upper shaft keying portion 320, a stop 324, a lower shaft 328, a lower shaft keying portion 326, and a centerline axis 330, as previously described. The upper shaft keying portion 320 engages with the lower shaft keying portion 326 at a keying interface region. In FIG. 3A, the locking element 314 is shown in a locked position.

[0045] In addition, the upper housing portion 308 and the lower housing portion 310 are threadably engaged in an engagement region 336. The lower housing portion 310 receives the drive bolt 306 before securing the upper housing portion 308 to the lower housing portion 310. The drive bolt 306 further includes a ledge portion that retains the drive bolt 306 within the housing portions 308,310. The ledge portion of the drive bolt 306 is located between an upper washer 332 and a lower washer 334.

[0046] The drive bolt 306 includes a drive portion that is a six-pointed drive. It is understood that the drive portion can be a hex socket, phillips, slotted, TORX®, spline or other known drive configuration capable of receiving a driving tool.

[0047] In certain embodiments, the upper washer 332 is a polymeric material such as nylon 6/6 or thermoplastic material (e.g., polyethylene, polypropylene, polystyrene, acrylic, PVC, ABS, polycarbonate, polyurethane, polyphenylene oxide (PPO), polyphenylene sulfide (PPS), polyether block amides, nylon, and engineered thermoplastics). The lower friction and slight flexibility of the upper washer 332 ensures



a secure engagement between the upper housing 308 and lower housing 310 while also allowing the drive bolt 306 to rotate about the centerline axis 330.

[0048] In some embodiments, the lower washer 334 is any metallic material such as copper, tin, bronze, brass, copper, steel, or aluminum to allow a low friction engagement with the ledge portion of the drive bolt 306 thereby allowing a low friction rotation of the drive bolt 306.

[0049] It is understood that the upper washer 332 and lower washer 334 can be made of any of the materials described herein.

[0050] A lower portion of the drive bolt 306 is inserted into the upper end of the drive shaft 312. In one embodiment, the drive bolt 306 is adhesively attached to the drive shaft 312 by an adhesive epoxy along an interface surface 338. The amount of interface surface 338 is dependent on the length of the drive bolt 306. In other embodiments, the drive bolt 306 can be mechanically attached or pinned with a mechanical fastener or keyed to the drive shaft 312 to ensure the drive bolt 306 rotates simultaneously by the same amount as the drive shaft 312.

[0051] In addition, the drive bolt 306 is axially restrained by the upper and lower housing 308,310 while still being capable of rotating freely upon a user inserting an engaging tool with the drive bolt 306 through an opening 302 in the end of the grip. In other words, a user's tool engages the drive bolt 306 through the butt end of the grip. In certain embodiments, the drive bolt 306 is located within about 25.4 mm (1") of the end of the grip for easy access. In one embodiment, the upper housing 308 and/or lower housing 310 is bonded, welded, mechanically attached, or adhesively attached to an inner surface of the upper end of the upper shaft 322.

[0052] FIG. 3A further illustrates the stop 316 located in a lower end of the drive shaft 312. The stop 316 is partially inserted into the drive shaft 312 and acts to prevent the over engagement of the locking element 314 when the locking element is moved to an unlocked position directly adjacent to the stop 316. Without the presence of the stop 316, the locking element 314 may become undesirably lodged when the locking element 314 is moved to a fully disengaged position in a second axial direction 118 along the centerline 330. In other words, the stop 316 helps prevent the locking element 314 from becoming immobilized or "stuck" when fully moved to an unlocked position.

[0053] As shown in FIG. 3A, the locking element 314 is located in a fully locked position where portions or fingers/arms of the locking element 314 are wedged between the plug 318 and the interior surface of the lower shaft 328, as will be described in further detail. The plug 318 includes a threaded portion 340 that engages with a threaded region of the locking element 314.

[0054] In one embodiment, the stop 324 is located at the lower end of the upper shaft 322 and acts to ensure a smooth engagement between the upper shaft 322 and lower shaft 328. The stop 324 also prevents the full disengagement of the upper shaft 322 from the lower shaft 328.

[0055] In certain embodiments, a weight zone is defined by an offset plane 346 that is measured from the end point 344 along the centerline axis 330 by a weight zone distance, d. The weight zone distance, d, is about 279.4 mm (11 inches) as measured along the centerline axis 330.

[0056] The offset plane 346 is perpendicular to the centerline axis 330. The weight zone extends between the endpoint 344, as previously described, and the offset plane 346 when

the lower shaft 328 is fully inserted or retracted in the upper shaft 322. In the fully retracted position, the weight zone has the heaviest weight configuration. Therefore, the components within the weight zone must be below a certain weight in order to avoid a negative impact on the swing of a golfer. If the total weight of the club within the weight zone (including all parts and materials within the weight zone) is too heavy, the golfer may not experience the desired feel and performance.

[0057] In certain embodiments, the total weight of the club within the weight zone is less than 110 g or between about 110 g and about 15 g. In some embodiments, the total weight of the club within the weight zone is less than 85 g or between about 85 g and about 20 g. In one embodiment, the total weight of the club within the weight zone is less than 75 g or between about 75 g and about 25 g. In some embodiments, the total weight of the club within the weight zone is less than 65 g or between about 65 g and about 25 g. Furthermore, in certain embodiments, the total weight of the club within the weight zone is less than 55 g or between about 55 g and about 25 g.

[0058] FIG. 3B illustrates the same embodiment shown in FIG. 3A having the components described above and the locking element 314 in an unlocked position.

[0059] FIG. 3C shows a detailed view of the locking element 314 in the unlocked position as taken from FIG. 3B. The plug body 318 includes a hollowed region 342 that reduces the overall weight of the plug 318. In addition, the plug 318 includes a threaded region 340 that receives the locking element 314. In the unlocked position, the locking element is moved in the second axial direction 118 and a top portion of the locking element abuts or is in direct contact with the stop 316. As previously mentioned, the stop 316 prevents an over-tightening of the locking element 314 on the threads 340. The locking element 314 fingers or protrusions 350 are no longer wedged or engaged between the plug surface 348 and the interior wall 354 of the lower shaft 328. Therefore, the upper shaft 322, drive shaft 312, and locking assembly including the locking element 314 and plug 318 are able to move in either a first axial direction 116 or second axial direction 118 with respect to the lower shaft 328.

[0060] In use, in one embodiment, a first rotational movement by the drive bolt 306 and drive shaft 312 causes the plug 318 to rotate while the locking element 314 remains rotationally restrained or stationary through the frictional engagement interface 352 (or other means described in further detail) with the interior wall 354. As the plug 318 rotates and engages the locking element 314 through the threaded portion 340, the locking element 314 moves in the first axial direction 116. Even though the locking element 314 is rotationally restrained, the locking element 314 is able to move in an axial direction parallel with the centerline axis 330 while being rotationally restrained. A movement of the locking element 314 in the first axial direction 116 causes a portion of the locking element 314 to engage or wedge between the inner surface of the lower shaft 328 and an outer surface 348 of the plug 318 into a locking position. The friction created between the threaded region 340 of the plug 318 and the locking element 314 during rotation is relatively low when compared to the friction between the outer surface of the locking element 314 and the inner surface 354 of the lower shaft 328. Thus, after locking, the adjustable golf club shaft 300 is ready for use. In other words, a force applied by the user on either the upper shaft 322 or the lower shaft 328 will not cause any

rotational or axial movement between the upper shaft 322 and lower shaft 328 due to the locking element 314 being engaged.

[0061] In contrast, a second rotational movement by the drive shaft 312 in an opposite direction of the first rotational movement causes the locking element 314 to disengage from the inner surface 354 of the lower shaft 328 and the plug 318. Therefore, the locking element 314 will move in the second axial direction 118 with respect to the lower shaft 328. Thus, after unlocking, the adjustable golf club shaft 300 can be adjusted by the user to a desired position before re-engaging the locking element 314.

[0062] In certain embodiments, the upper shaft 322 can travel at least 76.2 mm (3 inches) or 101.6 mm (4 inches). In other embodiments, the upper shaft 322 can travel between about 101.6 mm (4 inches) and 254 mm (10 inches). Depending on the type of shaft, the upper shaft 322 can travel more than 254 mm (10 inches) with respect to the lower shaft 328.

[0063] FIG. 3D illustrates a detailed view of the stop 324 located at an end of the upper shaft 322 taken from FIG. 3B. In some embodiments, the stop 324 may act as a stop that prevents the lower shaft 328 from being completely removed from the upper shaft 322 in the first axial direction 116. In one embodiment, the stop 324 is in direct engagement with the outside diameter surface of the lower shaft 328. A keying portion 320 of the lower shaft 328 has a greater outside diameter than the inside diameter of the stop 324. A small gap 356 is present between the non-keyed portion of the lower shaft 328 and the inside diameter of the upper shaft. Therefore, when the upper shaft 322 is fully extended in the second axial direction 118, the keying portion 320 of the lower shaft 328 engages with the protruding ledge of the stop 324 to prevent full disengagement.

[0064] FIG. 3E illustrates a cross-sectional view taken along cross-section lines 3E-3E in FIG. 3B. In one embodiment, the keying portions 320,326 are shown to be interlocking splines. In one example, the keying portions 320 of the lower shaft 328 include about eight splines. It is understood any number of splines can be used such as between one and sixteen splines. The keying portions 326 of the upper shaft 322 are configured to conform with the keying portions 320 of the lower shaft 328. The interlocking keying portions 320,326 ensure that a rotational motion is prevented between the two shafts. The keying portions 320,326 are symmetrical about the centerline axis 330.

[0065] In one embodiment, the keying portions 320 on the lower shaft 328 are created by applying multiple composite layers or "lay ups" to increase the outside diameter of the lower shaft 328. Subsequently, the keying portions 320 are created by cutting or machining slots parallel to the centerline axis 330 to form spline teeth along a section of the lower shaft 328. The slots are also cut in a radial direction with respect to the centerline axis 330.

[0066] The inner diameter 358 of the lower shaft 328 has a significant impact on how much frictional engagement can be created between the outer surface of the locking element 314 and the inner surface 354 of the lower shaft 328. In some embodiments, an inner diameter 358 is between about 0.400" to about 0.550" or preferably between about 0.440" to about 0.530".

[0067] FIG. 4 shows an exemplary cross-sectional view according to another embodiment. The grip cover 404, centerline axis 430, lower shaft keying portion 420, upper shaft keying portion 426, lower shaft 428, and upper shaft 422 are

shown. In one embodiment, three equidistantly spaced splines are shown being symmetric about the centerline axis 430.

[0068] FIG. 5 illustrates an exemplary cross-sectional view according to another embodiment. The grip cover 504, centerline axis 530, lower shaft keying portion 520, upper shaft keying portion 526, lower shaft 528 and upper shaft 522 are also shown. In one embodiment, the keying portions form an octagonal shape. In some embodiments, other geometric shapes can be formed to act as a keying portion. For example, a triangular, hexagonal, pentagonal, truncated circle, square, or D-shaped contour can be used on the outer surface of the lower shaft. The geometric shape selected will conform with the USGA Rules of Golf. The geometric shape formed by the keying portions 526,520 prevents the rotation of the lower shaft 528 with respect to the upper shaft 522.

[0069] FIG. 6A illustrates an exemplary embodiment of a locking element 600 having four expandable members or fingers 602 within an end region. The locking element 600 includes four tabs or finger portions 602 on a lower end of the locking element 600. The finger portions 602 are formed by four slots 604 spaced equidistant from one another around a circumference of the locking element 600. It is understood that certain embodiments can have more than two slots or at least four expandable finger portions without departing from the scope of this invention. At least one advantage of having at least four expandable fingers portions 602, is that it provides an equally distributed force about the circumference of the locking element 600 and plug while engaged in the locked position. In certain embodiments, the finger portions 602 can be biased outwardly away from the centerline axis 606 so that they will engage with the engagement surface of the plug described above.

[0070] Optionally, the locking element can include a frictional coating 608 that can be applied to the outer surface of the locking collar 600. In one embodiment, the frictional coating 608 is a urethane or polyurethane coating. The frictional coating 608 can be applied to the outer surface of the base cylinder of the locking element 600 or the outer surface of the finger portions 602. In addition, it is understood that the frictional coating 608 can be applied to the entire outer surface of the locking element 600 including the finger portions 602 and the base portion.

[0071] FIG. 6B illustrates a cross sectional view of the locking element 600 having the bore hole 610, finger portions 602, centerline 606, slots 604, threaded portion 614, and a base portion 612. The locking element 600 further includes the base portion 612 being connected with the finger portions 602. The outer diameter of the base portion 612 and finger portions 602 are frictionally engaged with the inside diameter of the lower shaft, as previously described.

[0072] In order for the present invention to function properly, the locking element 600 must be rotationally restrained within the lower shaft during a rotation of the plug while being allowed to move axially along the centerline 606 axis. Therefore, the coefficient of friction between the locking element 600 and plug is less than the coefficient of friction between the locking element 600 and lower shaft surface.

[0073] In one embodiment, the locking element 600 or plug is comprised of a glass filled polycarbonate or nylon material having a static coefficient of friction value of about 0.252 or less. In another embodiment the locking element 600 is comprised of a poly(tetrafluoroethylene) material (such as Teflon®) having a coefficient of friction value of about 0.05

or less or a polyoxymethylene material (such as Delring) having a coefficient of friction of about 0.192 or less. In preferred embodiments, a material having a coefficient of friction of less than about 0.5 is preferred. In other preferred embodiments, a coefficient of friction of less than about 0.3 for the locking element 600 or plug is preferred. In another exemplary embodiment, the locking element 600 can be an aluminum or low friction polished metallic material. It is understood that any low friction material described herein can be used without departing from the scope of the present invention.

[0074] In further embodiments, the locking element 600 is a low friction material described above having an outer surface of the base portion 612 and/or finger portions 602 covered in a high friction coating or spray. The friction coating or spray is provided to create increased rotational friction while allowing the collar to slide freely along an axial direction. In one embodiment, the inside surface of the lower shaft has a static coefficient of friction of about 0.80 or more.

[0075] In one embodiment, the ends of the finger portions 602 include flattened portions 616 that increase the amount of surface area contact between the locking element 600 and the inner surface of the lower shaft. The more surface area contact present, the greater the frictional engagement when the locking element is moved to the locking position. In one embodiment, the taper angle of the flattened portions 616 (away from the outer surface of the finger portions 602) is about 10 to 20 degrees or more.

[0076] FIG. 6C is a bottom view perspective of the locking element 600 including the components described above. In other embodiments, different types of locking elements can be used such as the Komperdell® Duo lock mechanism that includes a dual-wedge locking mechanism that is engaged when the drive shaft is rotated.

[0077] FIG. 9A shows an exemplary cross-sectional assembly view according to another embodiment 900. The grip cover 904, centerline axis 930, lower shaft keying portion 920, upper shaft keying portion 926, lower shaft 928, and upper shaft 922 are shown. In one embodiment, the lower shaft keying portions 920 includes four equidistantly spaced splines that are symmetric about the centerline axis 930.

[0078] FIG. 9A further shows a locking element 918 disposed within the lower shaft 928 (as viewed from the base portion side of the locking element 918). The locking element 918 includes ribs or detents 910,911,912,914 that are equally and symmetrically spaced about the centerline axis 930 and are located on the outer surface of the base portion of the locking element 918. The ribs or detents 910,911,912,914 are configured to engage with four symmetrically spaced notches or grooves 902,906,907,908 to prevent the rotation of the locking element 918 during the rotation of the drive shaft. The locking element 918 includes a threaded opening 924 and locking fingers 916 as previously described. In one embodiment, the notches or grooves 902,906,907,908 are each located in the region of a corresponding lower shaft keying portion 920 in four locations in order to maintain the structural rigidity of the lower shaft 928. The placement of the notches or grooves 902,906,907,908 in the thickened region of the lower shaft keying portion 920 also prevents the lower shaft 928 walls from becoming too thin and subject to mechanical failure.

[0079] FIG. 9B illustrates an isometric view of an exemplary locking element 918 including a base portion 932, finger portion 916 and ribs 910,911,912,914, and threaded open-

ing 924 as previously described. The ribs 910,911,912,914 are positioned to be aligned with the slots 913 located in-between each finger portion 916. Therefore, the corresponding grooves 902,906,907,908 of the lower shaft 928 are also aligned with the slots 913. Thus, the fingers portions 916 engage only with the non-slotted surfaces of the lower shaft 928 to ensure greater frictional contact.

[0080] FIG. 10 illustrates a cross-sectional assembly view according to another embodiment. The grip cover 1004, centerline axis 1030, lower shaft keying portion 1020, upper shaft keying portion 1026, locking element 1018, finger portions 1016, finger portion slots 1012, threaded opening 1024, lower shaft 1028, and upper shaft 1022 are shown.

[0081] In addition, the finger portions 1016 include a first finger 1002, a second finger 1008, a third finger 1006, and a fourth finger 1010. Each finger has a geometric surface that is configured to engage with the interior surface 1032 of the lower shaft 1028. In one embodiment, each finger includes at least two flat surfaces that form an apex or ridge 1014. The apex or ridge 1014 of each finger portion 1002,1008,1006, 1010 engages with the interior surface 1032 of the lower shaft 1028 to prevent the rotation of the locking element 1018 upon rotation of the drive shaft.

[0082] In one embodiment, the interior surface 1032 of the lower shaft 1028 is an octagonal shape although many different shapes can be used depending on the number of fingers and corresponding surface geometries. It is understood that the ribs or detents and corresponding grooves previously described can be implemented in the embodiment of FIG. 10.

[0083] FIG. 11 illustrates another cross-section assembly view according to another embodiment 1100. The grip cover 1104, centerline axis 1130, lower shaft keying portion 1120, upper shaft keying portion 1126, locking element 1118, finger portions 1116, threaded opening 1124, lower shaft 1128, and upper shaft 1122 are shown. The locking element 1118 includes a first rib 1110, second rib 1112, third rib 1114, and fourth rib 1111 on the base portion as previously described. The ribs 1110,1111,1112,1114 are received by a corresponding lower shaft 1128 first engaging groove 1102, second engaging groove 1106, third engaging groove 1108, and fourth engaging groove 1113 respectively.

[0084] In addition, the upper shaft 1122 includes at least one intermediate groove 1132,1133,1134,1136 located in-between each upper shaft keying portion 1126. In one embodiment, four intermediate grooves 1132,1133,1134,1136 are provided. The intermediate grooves 1132,1133,1134,1136 are configured to remove weight from the upper shaft 1122 to reduce the weight within the weight zone while maintaining a rigid and durable structure. The upper shaft keying portions 1126 are formed by two protrusions 1125 configured to engage with the lower shaft keying portion 1120 to prevent rotation. The intermediate grooves 1132,1133,1134,1136 are located between the protrusions 1125 of the upper shaft 1122.

[0085] It is understood that selective portions of the upper shaft can include the mass saving features described above. For example, two or more sections along the centerline axis of the upper shaft 1122 can include intermediate grooves 1132, 1133,1134,1136 while other sections of the upper shaft 1122 would have a constant thin-wall diameter or no intermediate grooves.

[0086] FIG. 7A illustrates an exemplary lower shaft 700 including a centerline axis 708, keying portion length 706, keying portion 710, and slots 712 as previously described. In

addition, the lower shaft **700** includes a keying portion **706** first outside diameter **714** and a non-keying portion **716** having a second outside diameter. The non-keying portion **716** also has a shaft wall thickness **704**. In some embodiments, the shaft wall thickness **704** is between about 0.5 mm and 1.5 mm or preferably about 1 mm.

[0087] In some embodiments, the first outside diameter **714** is between about 0.500" and about 0.700". In one embodiment, the first outside diameter **714** is about 0.600" or about 0.680".

[0088] The length **706** of the keying portion **710** has an axial length between about 101.6 mm (4") and about 279.4 mm (11"). In one embodiment, the keying portion **706** has an axial length of about 254 mm (10") or about 148 mm (5.8"). It is understood that the keying portion **710** can be provided in multiple segments. For example, two, three, or more keying portions **710** can be intermittently provided on the lower shaft **700** within the keying portion lengths **706** described above. For ease of illustration, only one keying portion **710** is shown in FIG. 7A.

[0089] However, FIG. 8 illustrates an alternative embodiment where multiple sections **804,808** of keying portions are provided with at least one intermittent non-keying portion **806** in between the multiple keying portions **804,808**. Providing at least one intermittent non-keying portion **806** can also help reduce weight in the weight zone portion of the shaft.

[0090] FIG. 7B illustrates an assembled view **722** of the lower shaft **700** with the upper shaft **720** prior to having the grip cover attached. The upper shaft **720** includes an upper shaft outside diameter **718** between about 0.600" and 0.700". In some embodiments, the second outside diameter **702** of the lower shaft **700**, at an upper shaft **720** end region **724**, is between about 0.450" and 0.600". The second outside diameter **702** of the non-keying portion **716** of the lower shaft **700** at the axial location where the upper shaft **720** ends **724** should be large enough to reduce the amount of step between the lower shaft **700** and upper shaft **720**. In one embodiment, the second outside diameter **702** is measured on the lower shaft **700** in the end region **724** when the upper shaft **720** is fully engaged in a first axial direction **116**.

[0091] In other words, the upper shaft **720** is fully contracted and has a maximum overlap dimension **726**. The overlap dimension **726** is defined as the axial distance the upper shaft **720** overlaps with the non-keying portion **716**. The overlap dimension **726** can also represent the amount of adjustability possible by the user before the keying portion **710** of the lower shaft **700** is undesirably exposed. The overlap dimension **726** can be between about 1" and about 11". In one embodiment, the overlap dimension is between about 3" and 10".

[0092] In order for the adjustable shaft assembly to feel "normal" to a user, the difference between the upper shaft **720** outside diameter **718** and the second outside diameter **702** of the non-keying portion **716** should be minimized. In other words, the transition in relative diameters between the upper shaft outside diameter **718** and the second outside diameter **702** (of the lower shaft) at the end region **724** axial location includes a relatively small step. In embodiments where the upper shaft is tapered, the outside diameter **718** is measured at the end region **724** of the upper shaft **720**.

[0093] The relationship between the lower shaft second outside diameter **702** and the upper shaft **720** outside diameter **718** influences whether the golf club shaft will have the

same feel of a traditional, non-adjustable shaft. For example, an outside diameter **718** of the upper shaft **720** that is too large will influence the golfer's grip and feel negatively. Thus, an outside diameter **718** of the upper shaft **720** that is less than 0.700" (constant diameter) is desired.

[0094] Table 1 shows exemplary embodiments with an overlap dimension **726** of about 4". Each exemplary embodiment shows a specific upper shaft **720** outside diameter **718** range and a corresponding lower shaft second outside diameter **702** at the end region **724** axial location.

Example No.	Upper Shaft O.D. (inches)	Lower Shaft O.D. (inches)
1	≅0.700	≅0.450
2	≅0.700	≅0.500
3	≅0.700	≅0.550
4	≅0.650	≅0.450
5	≅0.650	≅0.500
6	≅0.650	≅0.520
7	≅0.650	≅0.530
8	≅0.650	≅0.540
9	≅0.650	≅0.550
10	≅0.650	≅0.560
11	≅0.650	≅0.570
12	≅0.650	≅0.580
13	≅0.650	≅0.590
14	≅0.650	≅0.600

[0095] As illustrated by the exemplary embodiments shown in Table 1, the upper shaft **720** outside diameter **718** is desirably below the threshold values shown. Given a smaller upper shaft **720** outside diameter **718**, a more traditional upper shaft feel is provided to the user.

[0096] In addition, the lower shaft second outside diameter **702** at the end region **724** location of the upper shaft **720** should be sufficiently larger than the threshold values shown above to provide the appearance of a smooth or small step transition from the upper shaft **720** to the lower shaft **716**.

[0097] One advantage of the embodiments described herein is that an effective locking element is provided within a shaft that can handle a large amount of rotational or axial force while providing a traditional feel and grip for the golfer. In some embodiments, an axial force of at least 500 N or 2000 N when applied to the longitudinal axis of the shaft does not cause any movement between the upper and lower shaft whatsoever. In addition, the upper and lower shafts can withstand torsional forces of at least 5 N-m to 10 N-m without allowing any movement between the two shafts. In some embodiments, the upper and lower shaft can withstand up to 600 N-m or 700 N-m without failure.

[0098] Another advantage of the embodiments of the present invention is that a relatively low number of turns are required by the user to lock and unlock the locking elements described above. In certain embodiments, less than one full rotation is required to lock or unlock the upper and lower shafts. Thus, a user can easily and quickly adjust the length of the shaft without a large amount of effort.

[0099] Another advantage of the embodiments of the present invention is that a reliable and effective arrangement is provided to efficiently lock and unlock an upper and lower shaft. In embodiments where the upper shaft is a composite material, a lightweight adjustable grip portion is described herein. In addition, the components described herein are produced and assembled to be free of rattle and noise that might be undesirable to a user.

**[0100]** Furthermore, another advantage of the embodiments of the present invention is that an adjustable shaft is provided that aesthetically looks normal to a user on the exterior. The adjustable shaft can also be re-gripped with a standard or oversized replacement grip after the original grip is worn or no longer desired.

**[0101]** Another significant advantage of the embodiments described herein is that the grip appears “normal” in appearance and weight while providing a lightweight locking system. Minimizing weight is an advantage and therefore carbon fiber, aluminum, titanium, magnesium, and plastic would be used where strength and durability requirements allow. The present embodiments minimize overall weight by having the anti-rotation or keying features integrally incorporated into the grip. If an underlining type grip is used, a rigid plastic or molded composite piece can be made with anti-rotation features and an additional sliding tube will not be necessary. Thus, the overall part count and weight are reduced within a weight zone.

**[0102]** Any of the embodiments described herein can be configured to have any total club length. For example, a total club length of the embodiments described herein can be adjusted to about 1092.2 mm (43”), 1117.6 mm (44”), 1143 mm (45”), 1168.4 mm (46”), 1193.8 mm (47”), or 1219.2 mm (48”). In one embodiment, the length of the club can be a length in the range of about 38” to 48”.

**[0103]** The lower shaft of the embodiments described herein can include a shaft tip and hosel insert construction as described in U.S. patent application Ser. Nos. 12/346,747 and 12/474,973, herein incorporated by reference in their entirety. Specifically, the shaft tip of the lower shaft would include a hosel insert capable of being removed from the club head and repositioned to create a change in the loft, lie, or face angle of the club head.

**[0104]** The length of the club is measured according to the USGA Rules of Golf, Appendix II entitled “Length,” which is incorporated by reference in its entirety. Specifically, for woods and irons, the measurement of length is taken when the club is lying on a horizontal plane and the sole of the club head is set against a 60 degree plane. The length is defined as the distance from the point of the intersection between the two planes (horizontal plane and 60 degree plane) to the top of the grip.

#### Materials

**[0105]** The components of the above described components disclosed in the present specification can be formed from any of various suitable metals, metal alloys, polymers, composites, or various combinations thereof.

**[0106]** In addition to those noted above, some examples of metals and metal alloys that can be used to form the components of the connection assemblies include, without limitation, carbon steels (e.g., 1020 or 8620 carbon steel), stainless steels (e.g., 304 or 410 stainless steel), PH (precipitation-hardenable) alloys (e.g., 17-4, C450, or C455 alloys), titanium alloys (e.g., 3-2.5, 6-4, SP700, 15-3-3-3, 10-2-3, or other alpha/near alpha, alpha-beta, and beta/near beta titanium alloys), aluminum/aluminum alloys (e.g., 3000 series alloys, 5000 series alloys, 6000 series alloys, such as 6061-T6, and 7000 series alloys, such as 7075), magnesium alloys, copper alloys, and nickel alloys.

**[0107]** Some examples of composites that can be used to form the components include, without limitation, glass fiber reinforced polymers (GFRP), carbon fiber reinforced poly-

mers (CFRP), metal matrix composites (MMC), ceramic matrix composites (CMC), and natural composites (e.g., wood composites).

**[0108]** Some examples of polymers that can be used to form the components include, without limitation, thermoplastic materials (e.g., polyethylene, polypropylene, polystyrene, acrylic, PVC, ABS, polycarbonate, polyurethane, polyoxymethylene, polyphenylene oxide (PPO), polyphenylene sulfide (PPS), polyether block amides, nylon, and engineered thermoplastics), thermosetting materials (e.g., polyurethane, epoxy, and polyester), copolymers, and elastomers (e.g., natural or synthetic rubber, EPDM, and Teflon®). Furthermore, any of the above components can be made of nylon or glass filled nylon material and an injection molding process can be utilized in the production of any of the components mentioned herein.

**[0109]** In view of the many possible embodiments to which the principles of the disclosed invention may be applied, it should be recognized that the illustrated embodiments are only preferred examples of the invention and should not be taken as limiting the scope of the invention. For example, although a metal wood shaft is specifically described above, it is understood that the present invention can be applied to other golf club shafts including putters or irons. It will be evident that various modifications may be made thereto without departing from the broader spirit and scope of the invention as set forth. The specification and drawings are, accordingly, to be regarded in an illustrative sense rather than a restrictive sense.

We claim:

1. An adjustable length golf club shaft comprising:
  - a grip portion, the grip portion having an end region including an end point and further includes an upper shaft and grip cover;
  - a locking element located within the grip portion; and
  - a lower shaft having an inner surface that is in frictional contact with the locking element, wherein the locking element is configured to engage the inner surface of the lower shaft, wherein a total length of the golf club shaft is adjustable by a distance of at least one inch and a total weight of the golf club shaft in a weight zone is less than 110 g, the weight zone being defined as a region of the golf club shaft extending from the end point of the grip portion to 11” along a central axis of the golf club shaft toward a tip portion of the shaft.
2. The adjustable length golf club shaft of claim 1, wherein the grip portion is adjustable with respect to the lower shaft and a stop prevents the lower shaft from being completely removed from the grip portion.
3. The adjustable length golf club shaft of claim 1, wherein the total length of the golf club shaft is adjustable by a distance of at least 2 inches.
4. The adjustable length golf club shaft of claim 1, wherein the total length of the golf club shaft is adjustable by a distance of at least 3 inches.
5. The adjustable length golf club shaft of claim 1, wherein the total length of the golf club shaft is adjustable by a distance of at least 4 inches.
6. The adjustable length golf club shaft of claim 1, wherein the total weight of the golf club shaft in the weight zone is less than 85 g.
7. The adjustable length golf club shaft of claim 1, wherein the total weight of the golf club shaft in the weight zone is less than 75 g.

8. The adjustable length golf club shaft of claim 1, wherein the total weight of the golf club shaft in the weight zone is less than 65 g.

9. The adjustable length golf club shaft of claim 1, wherein the total weight of the golf club shaft in the weight zone is less than 55 g.

10. The adjustable length golf club shaft of claim 1, wherein the locking element prevents any axial movement between the grip portion and the lower shaft during an axial load of at least 2000 N.

11. The adjustable length golf club shaft of claim 1, wherein the lower shaft includes at least one first keying feature portion being symmetrical about the central axis.

12. The adjustable length golf club shaft of claim 11, wherein the grip portion includes at least one second keying feature portion configured to engage with the at least one first keying feature portion.

13. The adjustable length golf club shaft of claim 11, wherein the at least one first keying portion includes at least one spline.

14. The adjustable length golf club shaft of claim 11, wherein the at least one spline includes at least three splines.

15. The adjustable length golf club shaft of claim 11, wherein the at least one first keying portion includes at least two keying regions along the lower shaft.

16. The adjustable length golf club shaft of claim 1, wherein the total golf club length is between about 40" and about 48".

17. The adjustable length golf club shaft of claim 1, wherein the grip portion includes an upper shaft portion having an outside diameter of less than 0.700" and the lower shaft includes an outside diameter of greater than 0.450".

18. The adjustable length golf club shaft of claim 1, wherein the grip portion includes an upper shaft portion having an outside diameter of less than 0.650" and the lower shaft includes an outside diameter of greater than 0.500".

19. An adjustable length golf club shaft comprising:

an engaging mechanism;

a grip portion connected with the engaging mechanism, the grip portion including an upper shaft portion having an outside diameter of less than 0.700";

a shaft connected with the engaging mechanism and being configured to rotate upon movement by the engaging mechanism;

a locking element connected with the shaft, the locking element including at least one locking insert and at least one locking collar located on the at least one locking insert, the at least one locking insert being configured to engage the at least one locking collar during axial movement; and

a lower shaft having an inner surface that is in frictional contact with the at least one locking collar, the lower shaft including an outside diameter of greater than 0.450", wherein a first rotational movement in a first rotational direction by the shaft causes the at least one locking insert to engage the at least one locking collar creating a frictional locking engagement between the at least one locking collar and the inner surface of the lower shaft.

20. An adjustable length golf club comprising:

a golf club head;

a golf club shaft connected with the golf club head;

an engaging mechanism connected with the golf club shaft;

a grip portion connected with the engaging mechanism, the grip portion having an end region including an end point and further includes a grip cover and upper shaft;

a drive shaft connected with the engaging mechanism and being configured to rotate upon movement by the engaging mechanism;

a locking element connected with the drive shaft;

a total length of the golf club shaft, the total length of the golf club shaft being adjustable by a distance of at least one inch and a total weight of the golf club shaft within a weight zone is less than 110 g, the weight zone being defined as a region of the golf club shaft extending from the end point of the grip portion to 11" along a central axis of the golf club shaft; and

a lower shaft having an inner surface that is in frictional contact with the locking element, wherein a first rotational movement in a first rotational direction by the drive shaft causes the locking element to engage the inner surface of the lower shaft and a second rotational movement in a second rotational direction by the drive shaft causes the locking element to disengage from the inner surface of the lower shaft.

\* \* \* \* \*