



US 20110014994A1

(19) **United States**

(12) **Patent Application Publication**
Chuang

(10) **Pub. No.: US 2011/0014994 A1**

(43) **Pub. Date: Jan. 20, 2011**

(54) **GOLF PUTTER HEAD**

(22) Filed: **Jul. 14, 2009**

(75) Inventor: **Yi-Ping Chuang, Ping-Tung Hsien**
(TW)

Publication Classification

Correspondence Address:
TOWNSEND AND TOWNSEND AND CREW,
LLP
TWO EMBARCADERO CENTER, EIGHTH
FLOOR
SAN FRANCISCO, CA 94111-3834 (US)

(51) **Int. Cl.**
A63B 53/06 (2006.01)

(52) **U.S. Cl.** **473/325; 473/340; 473/342**

(73) Assignee: **O-TA PRECISION INDUSTRY**
CO., LTD., Ping-Tung Hsien (TW)

(57) **ABSTRACT**

A golf putter head includes a head body, and a face plate unit disposed on the head body and having one surface to serve as a putting face. The face plate unit has a plurality of faces surrounding an axis thereof and is rotatably coupled to the head body so that the face plate unit is rotatable about the axis to make one of the faces of the face plate unit serve as the putting face.

(21) Appl. No.: **12/502,910**

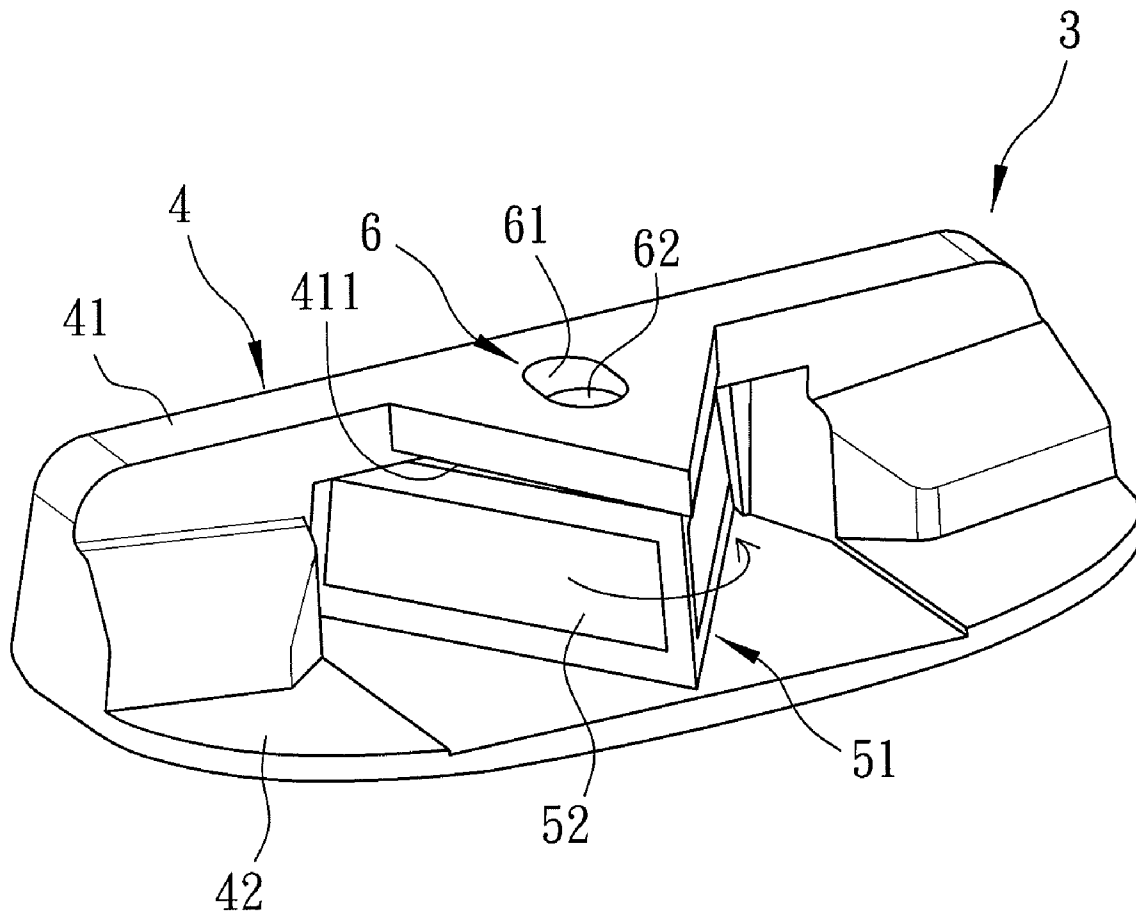

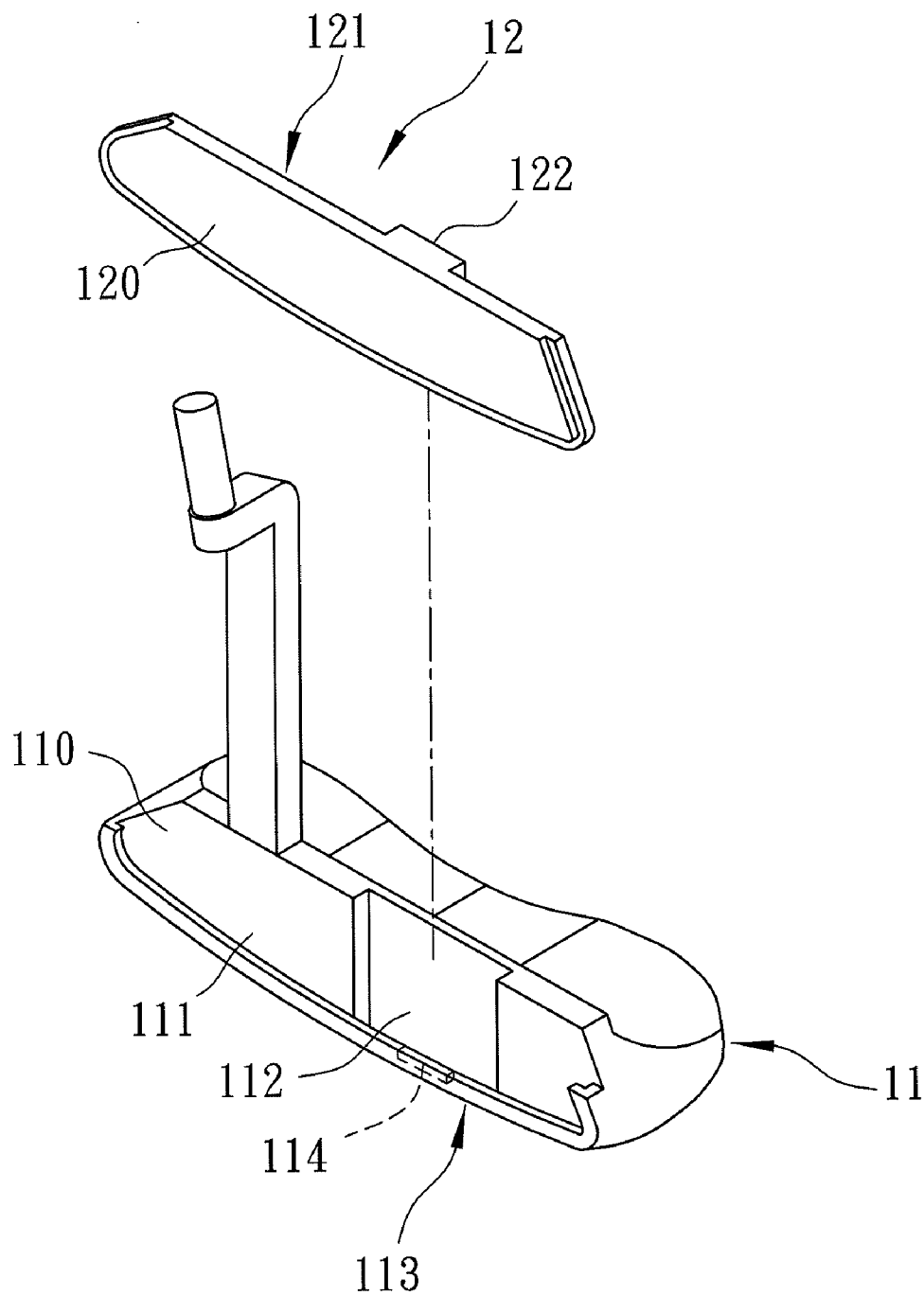

FIG. 1
PRIOR ART

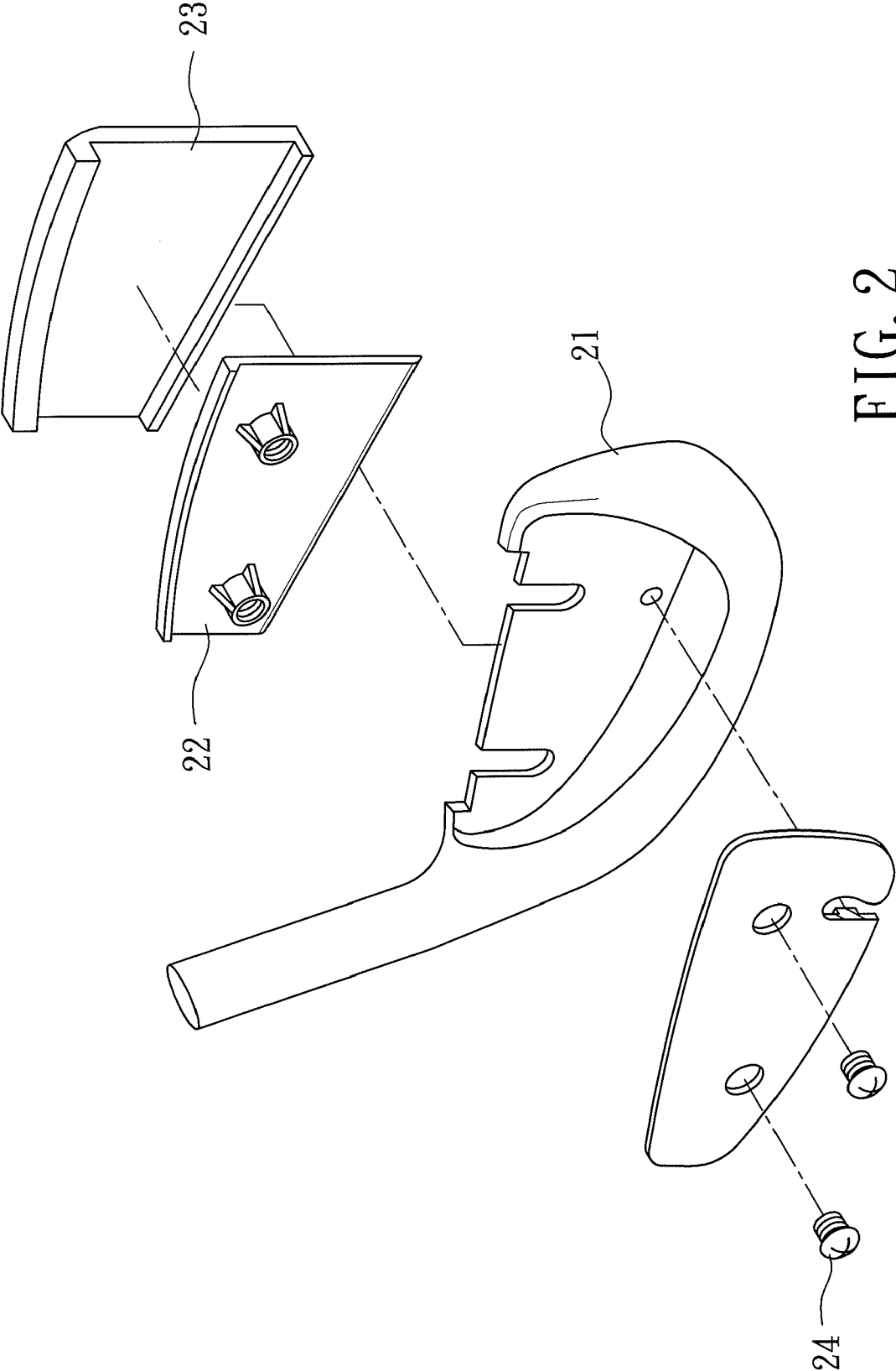

FIG. 2
PRIOR ART

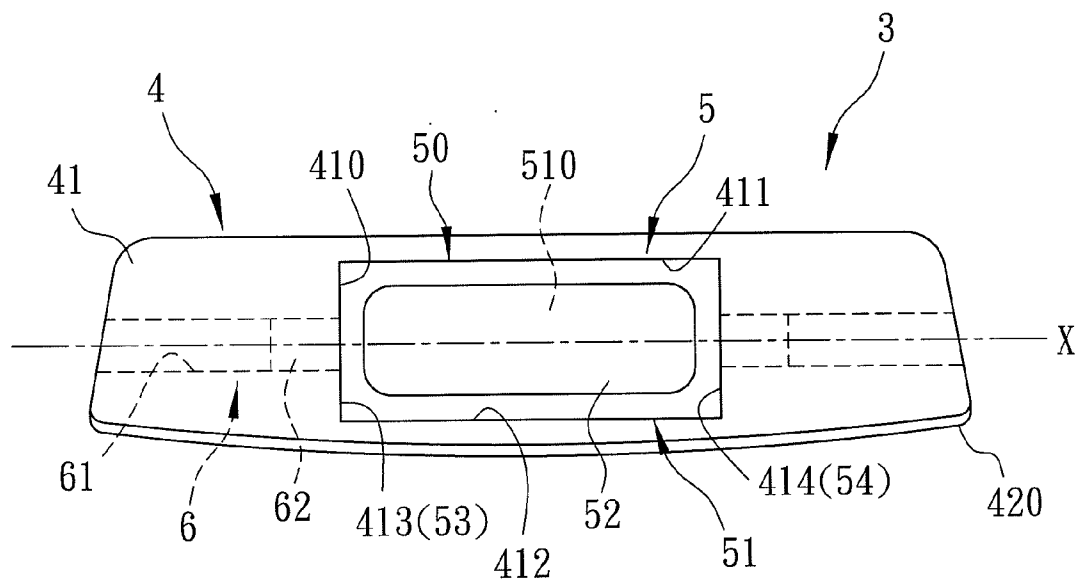

FIG. 3

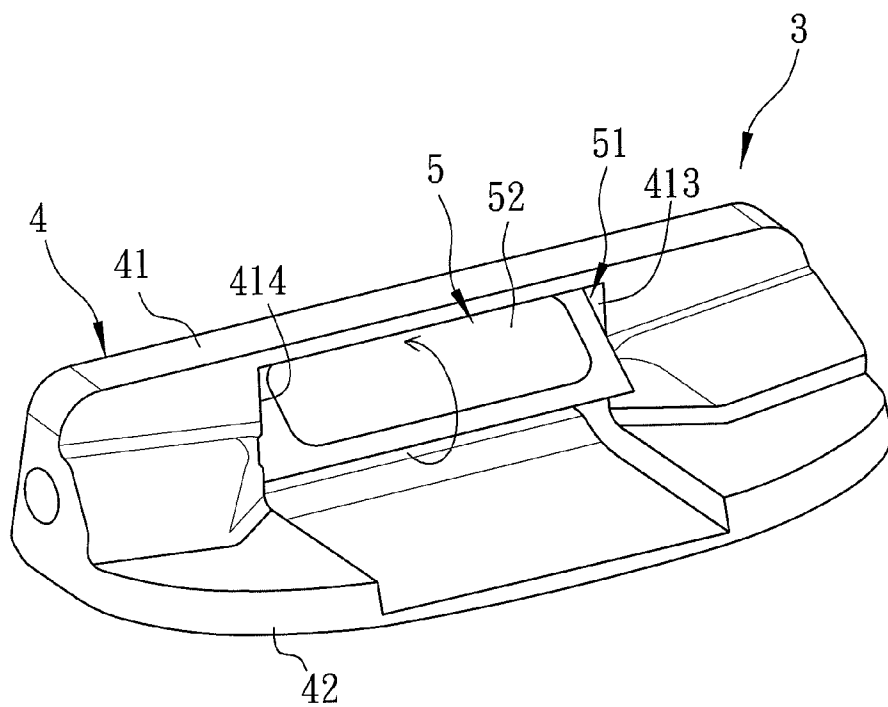

FIG. 4

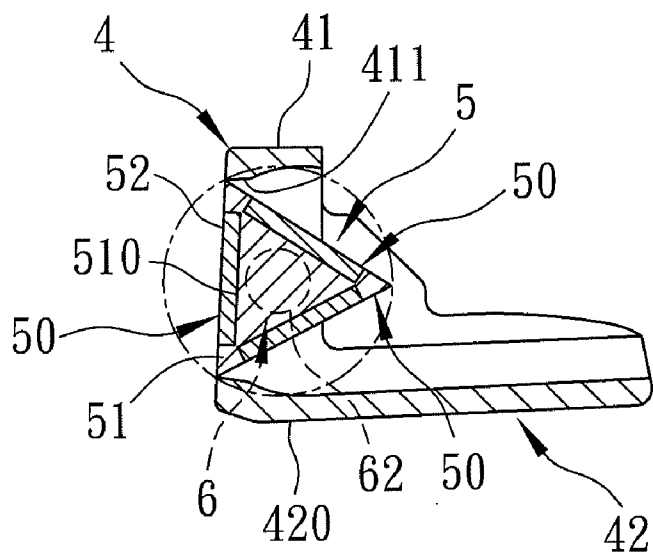

FIG. 5(a)

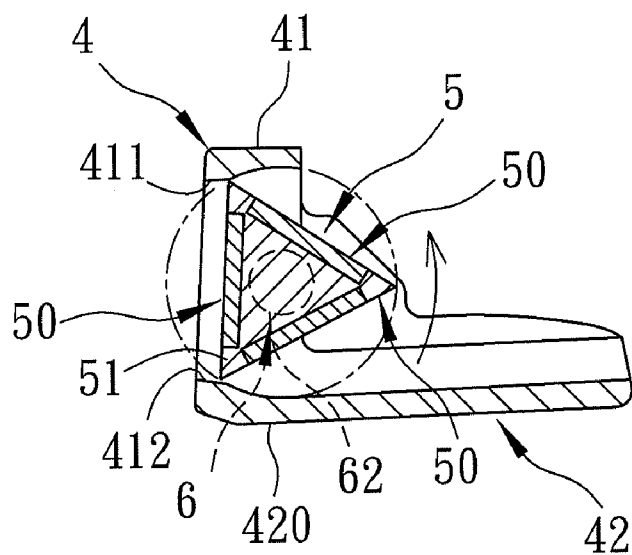

FIG. 5(b)

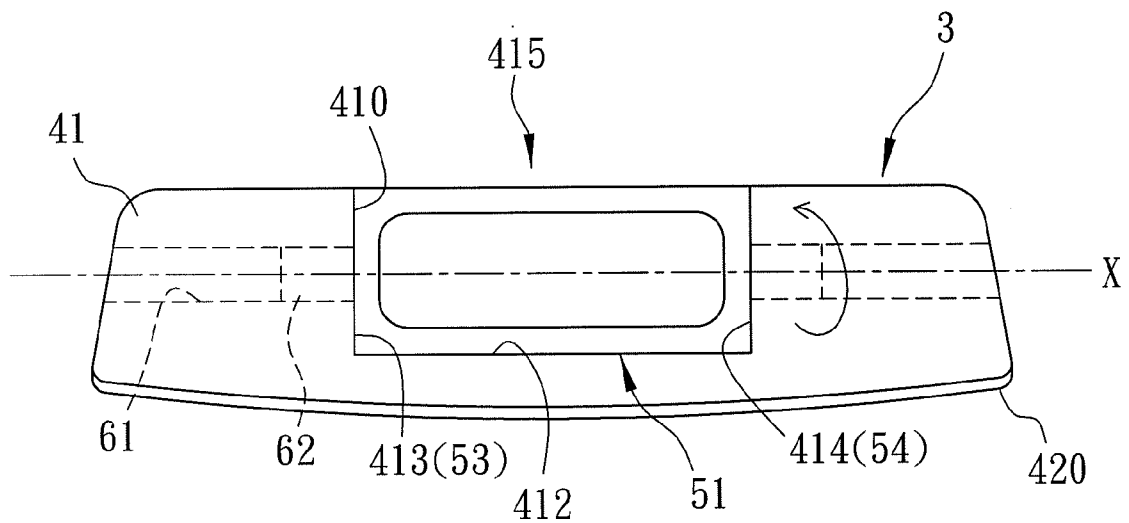

FIG. 6

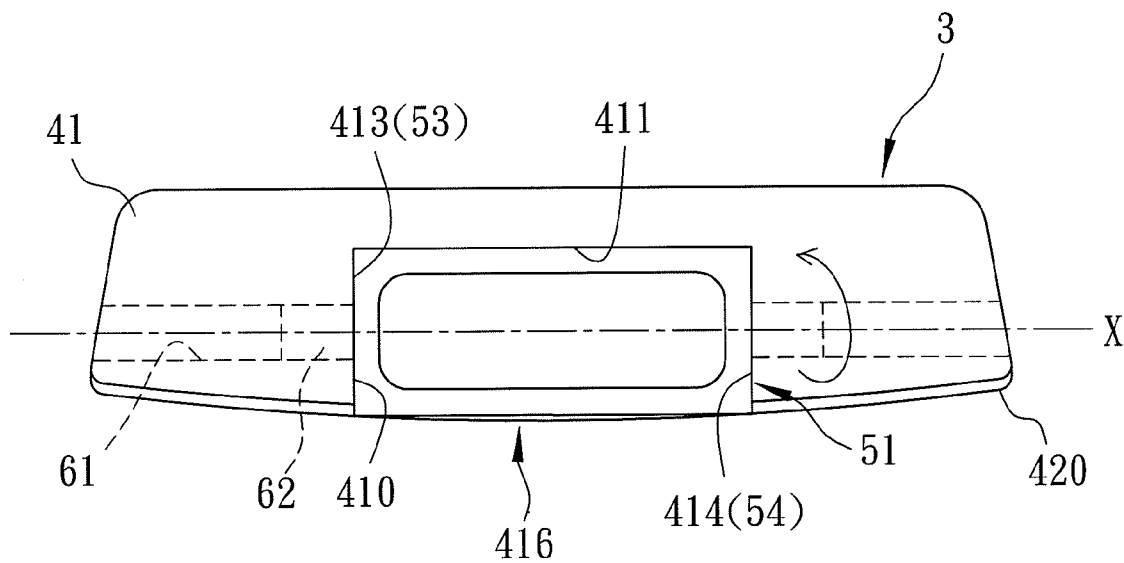

FIG. 7

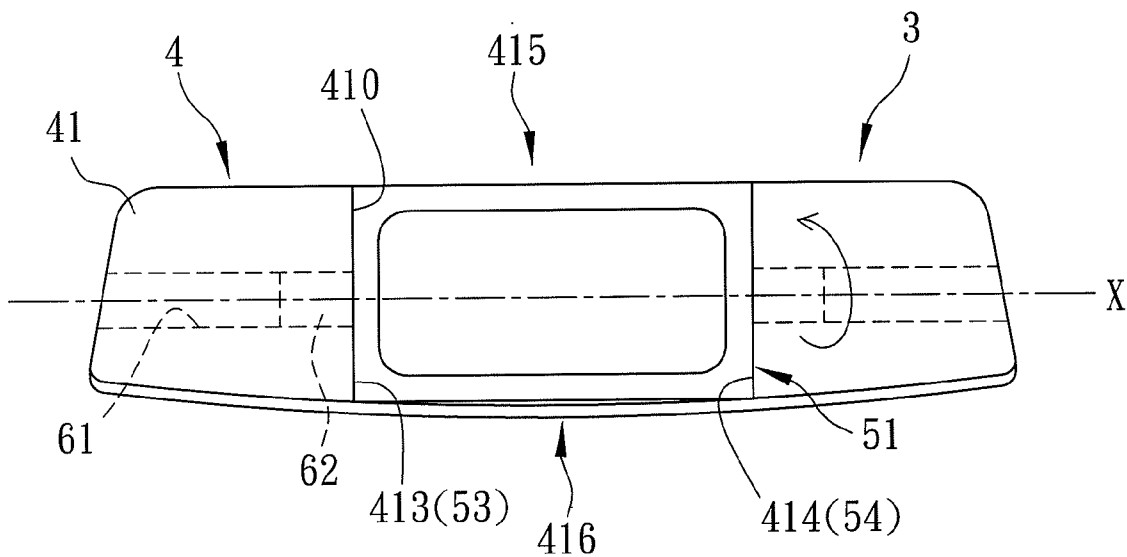

FIG. 8

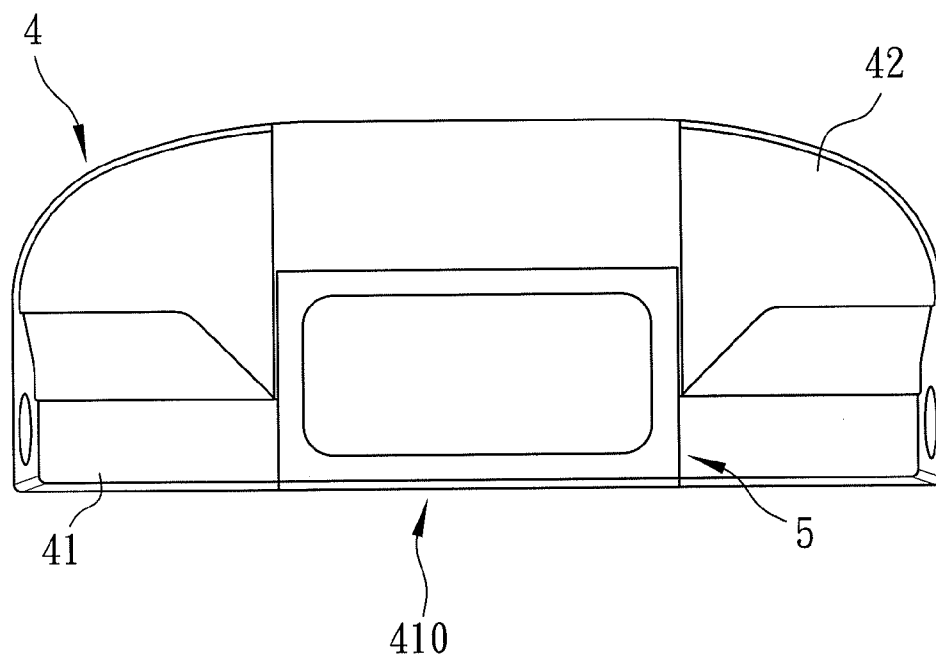

FIG. 9

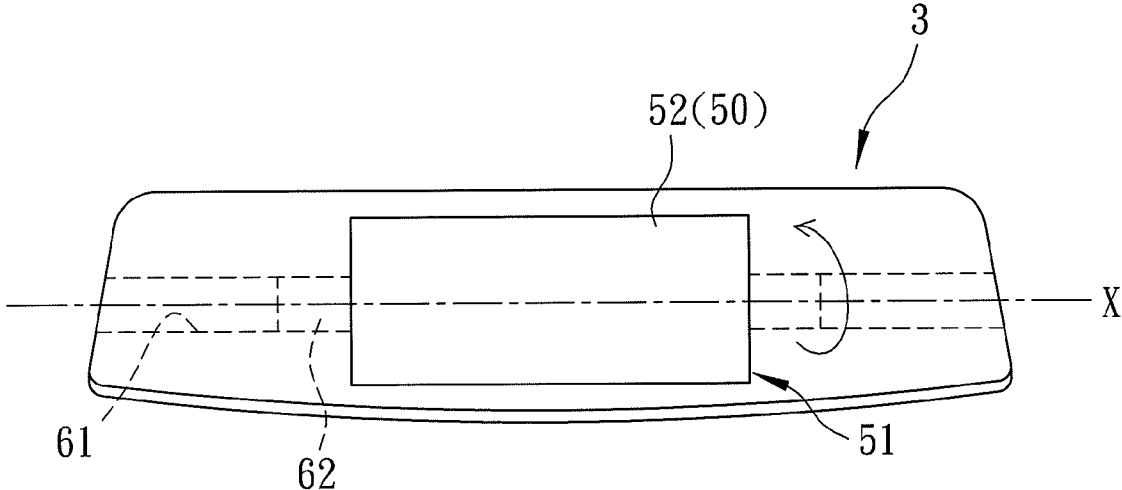

FIG. 10

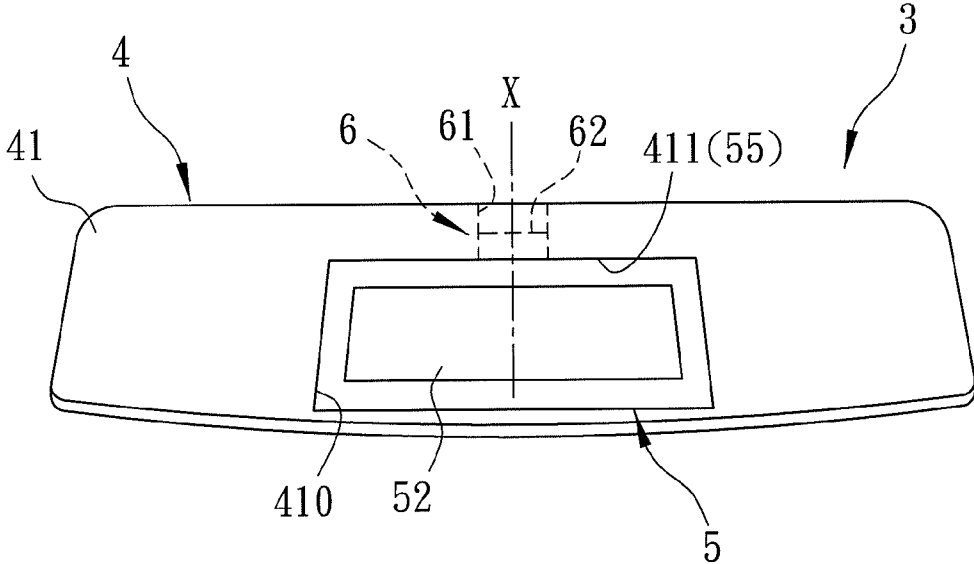

FIG. 11

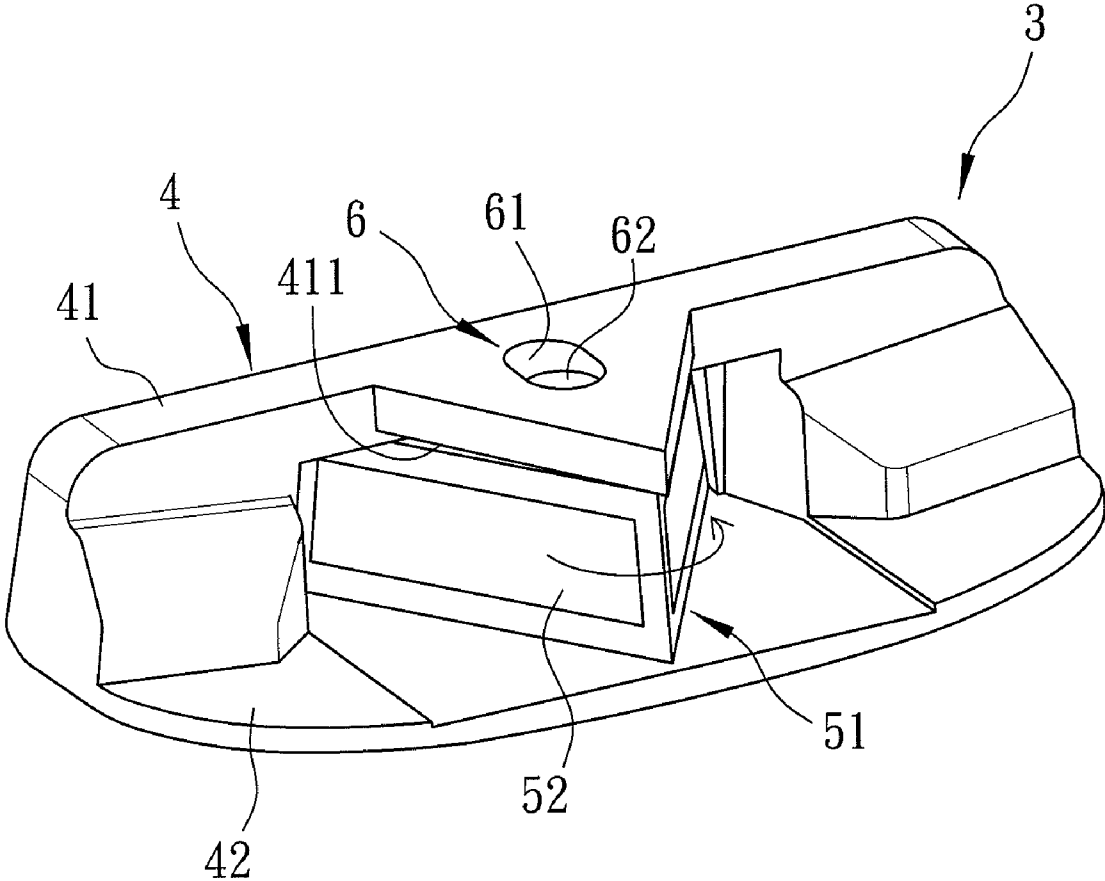

FIG. 12

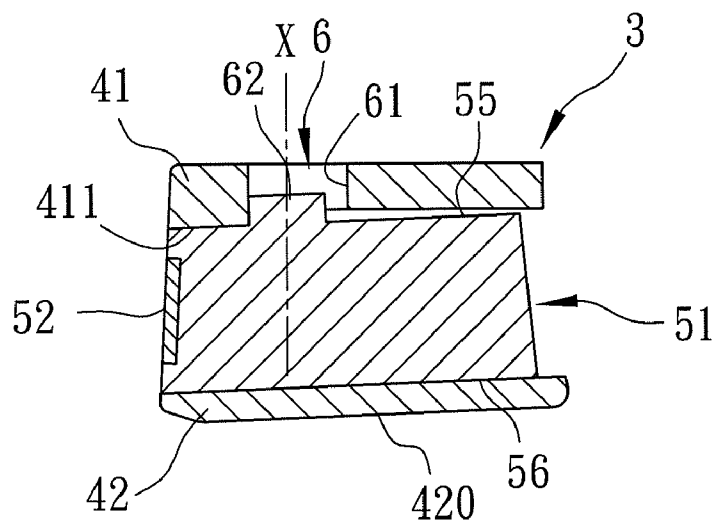

FIG. 13

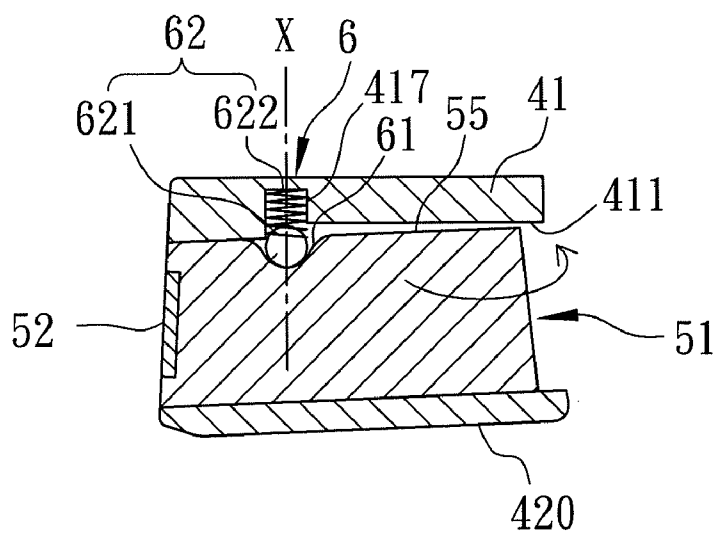

FIG. 14

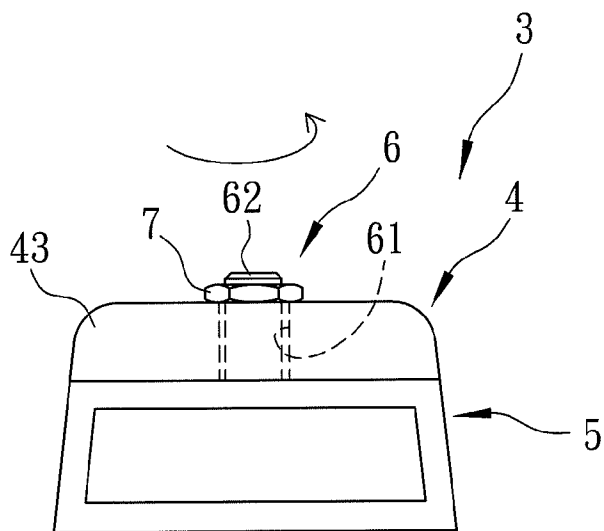

FIG. 15

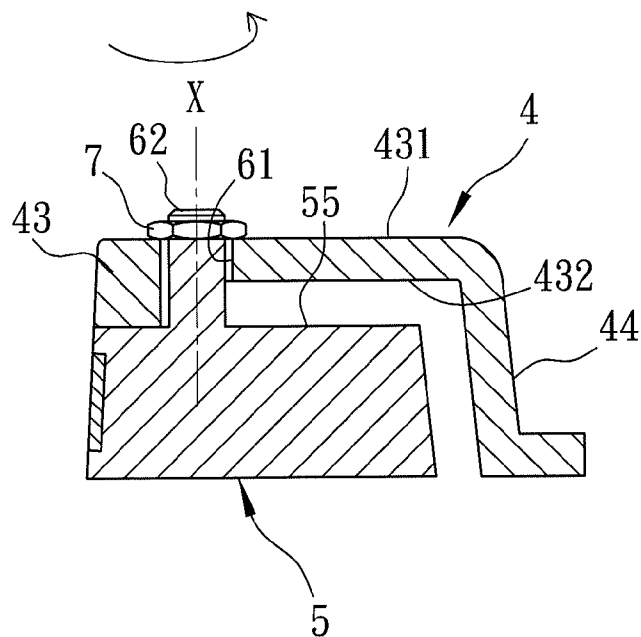

FIG. 16

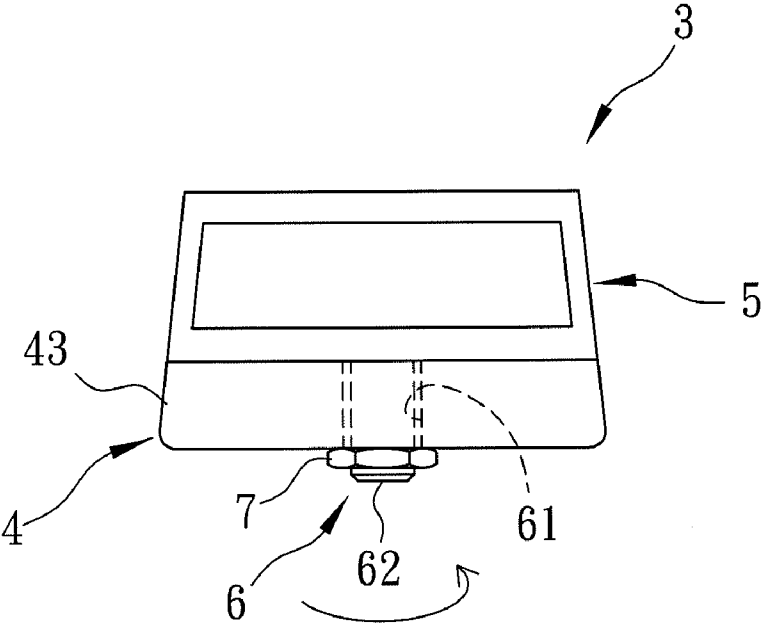

FIG. 17

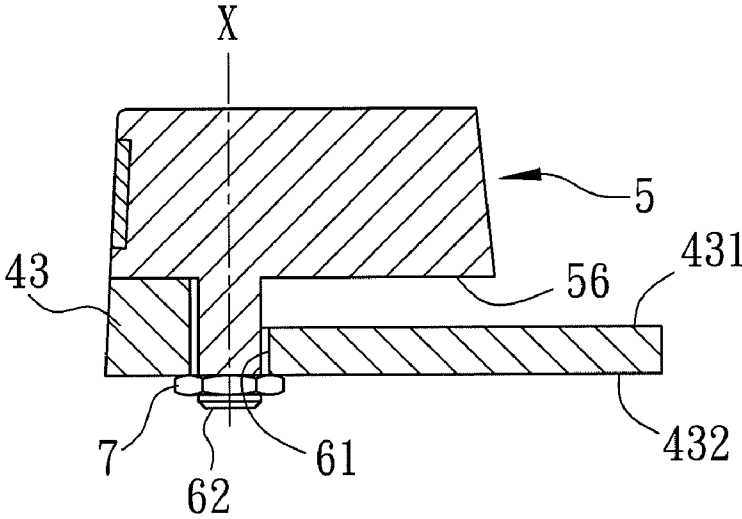

FIG. 18

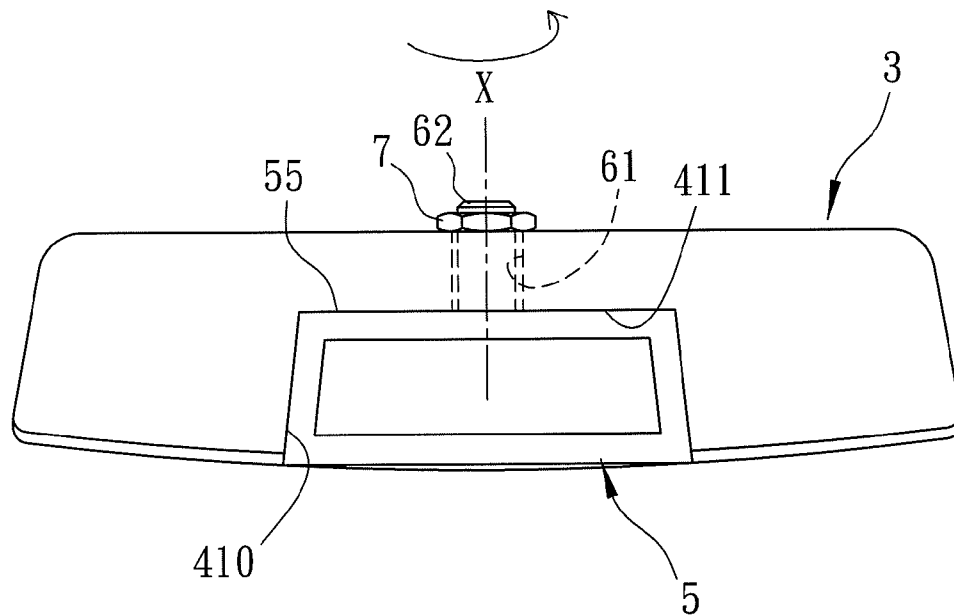

FIG. 19

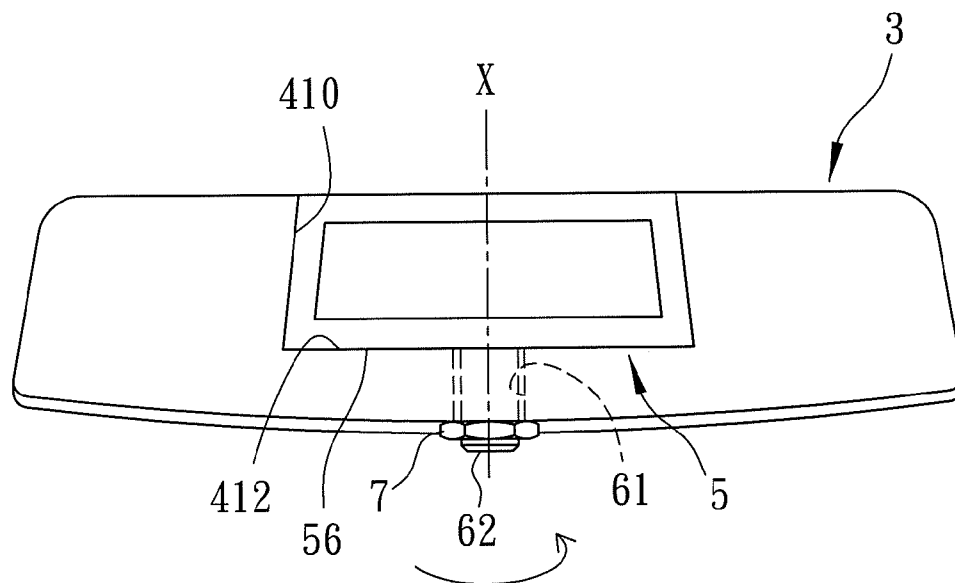

FIG. 20

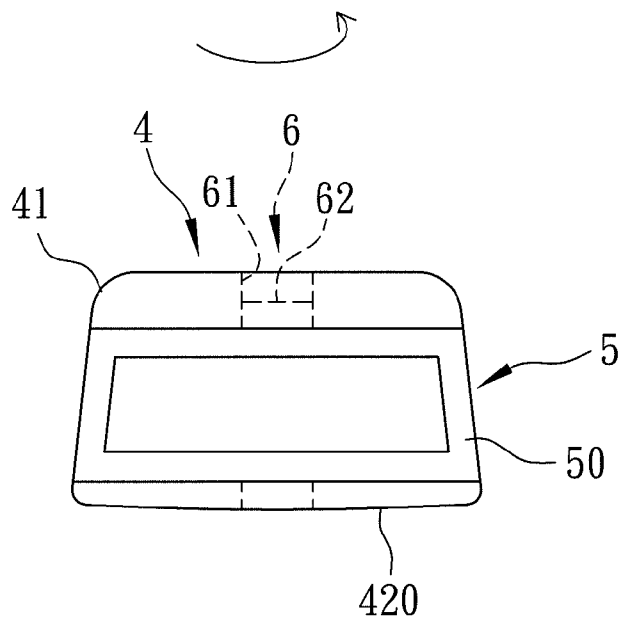

FIG. 21

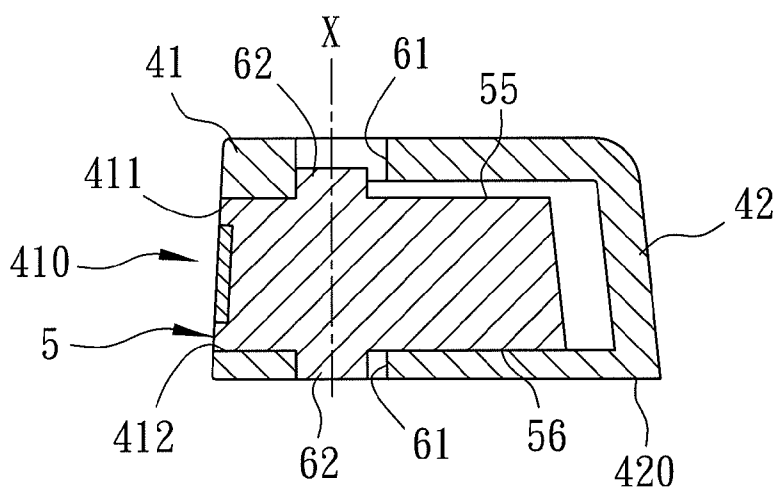

FIG. 22

GOLF PUTTER HEAD

BACKGROUND OF THE INVENTION

[0001] 1. Field of the Invention

[0002] This invention relates to a golf putter head, more particularly to a golf putter head with a replaceable face plate.

[0003] 2. Description of the Related Art

[0004] A golf putter is for putting a golf ball on a putting green. Usually, the green is not flat, and different levels of grass are varied to form different topography on the green. In order to hit the ball into a hole with the lowest possible number of strokes, it is necessary to prepare many kinds of golf putters, putting faces of which have different properties. However, when the number of the golf putters increase, it is hard for the golfer to carry a golf club set (including those putters) through the whole golf course. Thus, a golf putter head of a golf putter with a replaceable face plate has been proposed.

[0005] As shown in FIG. 1, a conventional golf putter head, which has a replaceable face plate mounted thereon, disclosed in Taiwan patent publication no. 439517 includes a head body **11** having a sole surface **113** to function as a sole when putting, and a face plate **12** having front and back faces **120, 121**. The head body **11** is formed to have a recessed opening **110** from a front side thereof, the front side being adapted for facing toward a golf ball when putting. The head body **11** is further formed with a groove **112** in a bottom face **111** of the recessed opening **110**, which is facing toward the front side, and an engaging hole **114** formed in the groove **112** for spatially communicating the groove **112** with the sole surface **113**.

[0006] The face plate **12** is provided with a counterweight unit **122** and a protrusion (not shown). The counterweight unit **122** is disposed on the back face **121** and extends longitudinally for adjusting the center of gravity of the whole golf putter. The protrusion is disposed below the counterweight unit **112** and on a lower edge of the face plate **12**, and is for inserting into the engaging hole **114** to interengage the head body **11** and the face plate **12**.

[0007] Therefore, when the counterweight unit **112** is inserted into the groove **112** and the protrusion is inserted into and engaged by the engaging hole **114**, the face plate **12** is filled in the recessed opening **110** with its front face **120** serving as a putting face. In the case of replacing the faceplate **12** according to the topography of the green, the protrusion is disengaged from the engaging hole **114** by extension of a tool (not shown) into the engaging hole **114**, such that the whole face plate **12** can be taken off and another face plate can be inserted into the head body **11**.

[0008] As shown in FIG. 2, another conventional golf club head is disclosed in Taiwan patent publication no. 193879. A face plate **23** of the golf club head is integrated with a reinforced body **22** by caulking, and is fixed to a head body **21** by screws **24**. Thus, when replacing the face plate **23**, the screws **24** should be loosened to remove the face plate **23** together with the reinforced body **22**, followed by fastening another set of a face plate and a reinforced body to the head body **21**.

[0009] However, in both of the aforementioned conventional golf club heads, the replacement of the face plates is inconvenient for the golfer since it should be conducted by the use of a tool. Furthermore, the face plates for replacement are

not mounted on the head body, and thus, there is a risk of misplacing those face plates in the case of the conventional golf club heads.

SUMMARY OF THE INVENTION

[0010] Therefore, an object of the present invention is to provide a golf putter head that can overcome the aforesaid drawbacks associated with the prior art.

[0011] According to one aspect of the present invention, there is provided a golf putter head comprising a head body, and a face plate unit disposed on the head body and having one surface to serve as a putting face. The face plate unit has a plurality of faces surrounding an axis thereof and is rotatably coupled to the head body so that the face plate unit is rotatable about the axis to make one of the faces of the face plate unit serve as the putting face.

[0012] According to another aspect of the present invention, there is provided a golf putter head comprising: a head body formed with an opening from a front side thereof, the front side being adapted for facing toward a golf ball when putting; and a face plate unit with one surface filled in the opening of the head body to serve as a putting face of the golf putter head. The face plate unit has a plurality of faces surrounding an axis thereof and is rotatably coupled to the head body so that the face plate unit is rotatable about the axis to make one of the faces of the face plate unit serve as the putting face.

[0013] Depending on design, each of the plurality of faces of the face plate unit can be provided with a face plate for serving as the putting face, or not provided with a face plate. In the latter case, the putting face is one of the plurality of faces of the face plate.

[0014] Furthermore, the counterweight unit for adjusting the center of gravity of the whole golf putter head can be disposed on the back of the face plate as in the prior art, can be disposed on a place of the face plate unit, which is other than the face plate, or can be disposed on the head body. Since the feature of the present invention does not reside in the counterweight unit of the golf putter head, the description of the counterweight unit will be omitted hereinafter.

BRIEF DESCRIPTION OF THE DRAWINGS

[0015] Other features and advantages of the present invention will become apparent in the following detailed description of the preferred embodiments of the invention, with reference to the accompanying drawings, in which:

[0016] FIG. 1 is an exploded perspective view of a conventional golf putter head disclosed in Taiwan patent publication no. 439517;

[0017] FIG. 2 is an exploded perspective view of a conventional golf club head disclosed in Taiwan patent publication no. 193879;

[0018] FIG. 3 is an elevational view illustrating a front side of a golf putter head of the first embodiment, which is adapted for facing toward a golf ball when putting;

[0019] FIG. 4 is a perspective view observed from a back side of the golf putter head of FIG. 3;

[0020] FIGS. 5(a) and 5(b) are cross-sectional views observed from a lateral side of the golf putter head of FIG. 3;

[0021] FIG. 6 is an elevational view illustrating a front side of a golf putter head of the second embodiment, which is adapted for facing toward a golf ball when putting;

[0022] FIG. 7 is an elevational view illustrating a front side of a golf putter head of the third embodiment, which is adapted for facing toward a golf ball when putting;

[0023] FIG. 8 is an elevational view illustrating a front side of a golf putter head of the fourth embodiment, which is adapted for facing toward a golf ball when putting;

[0024] FIG. 9 is a top view of the golf putter head of FIG. 8;

[0025] FIG. 10 is an elevational view illustrating a front side of a golf putter head of the fifth embodiment, which is adapted for facing toward a golf ball when putting;

[0026] FIG. 11 is an elevational view illustrating a front side of a golf putter head of the sixth embodiment, which is adapted for facing toward a golf ball when putting;

[0027] FIG. 12 is a perspective view observed from a back side of the golf putter head of FIG. 11;

[0028] FIG. 13 is a cross-sectional view observed from a lateral side of the golf putter head of FIG. 11;

[0029] FIG. 14 is a cross-sectional view observed from a lateral side of a golf putter head of the seventh embodiment;

[0030] FIG. 15 is an elevational view illustrating a front side of a golf putter head of the eighth embodiment, which is adapted for facing toward a golf ball when putting;

[0031] FIG. 16 is a cross-sectional view observed from a back side of the golf putter head of FIG. 15;

[0032] FIG. 17 is an elevational view illustrating a front side of a golf putter head of the ninth embodiment, which is adapted for facing toward a golf ball when putting;

[0033] FIG. 18 is a perspective view observed from a back side of the golf putter head of FIG. 17;

[0034] FIG. 19 is an elevational view illustrating a front side of a golf putter head of the tenth embodiment, which is adapted for facing toward a golf ball when putting;

[0035] FIG. 20 is an elevational view illustrating a front side of a golf putter head of the eleventh embodiment, which is adapted for facing toward a golf ball when putting;

[0036] FIG. 21 is an elevational view illustrating a front side of a golf putter head of the twelfth embodiment, which is adapted for facing toward a golf ball when putting; and

[0037] FIG. 22 is a cross-sectional view observed from a lateral side of the golf putter head of FIG. 21.

DETAILED DESCRIPTION OF THE PREFERRED EMBODIMENTS

[0038] Before the present invention is described in greater detail with reference to the accompanying preferred embodiments, it should be noted herein that like elements are denoted by the same reference numerals throughout the disclosure.

[0039] As shown in FIGS. 3-22, each of golf putter heads 3 in the first to twelfth embodiments of this invention is shown to include a head body 4, a face plate unit 5 disposed on the head body 4 and having one surface serving as a putting face, and a rotary joint mechanism 6.

[0040] The face plate unit 5 has a plurality of faces 50 surrounding an axis (X) thereof and is rotatably coupled to the head body 4 by the rotary joint mechanism 6 so that the face plate unit 5 is rotatable about the axis (X) to make one of the faces 50 of the face plate unit 5 serve as the putting face.

[0041] Referring to FIGS. 3, 4, 5(a) and 5(b), in the first embodiment, the head body 4 is L-shaped to have a straight portion and a flat portion when viewed laterally. The straight portion serves as a mounting part 41, and the flat portion serves as a base part 42. The mounting part 41 is formed with an opening 410 from a front side thereof, the front side being adapted for facing toward a golf ball (not shown) when put-

ting. The base part 42 has a sole surface 420 to function as a sole when putting. The mounting part 41 is formed with upper, lower, left and right inner walls 411, 412, 413, 414 that surround the opening 410. The upper and lower inner walls 411, 412 are substantially parallel to the sole surface 420, respectively, and the left and right inner walls 413, 414 are substantially perpendicular to the sole surface 420, respectively.

[0042] The face plate unit 5 is shaped as a regular triangular prism with three faces 50 that surround the axis (X) thereof, and left and right end faces 53, 54 that are connected with left and right sides of the three faces 50, respectively. Each of the three faces 50 has an equivalent surface area, but has a different property for putting.

[0043] Furthermore, the face plate unit 5 is rotatably coupled to the head body 4 by the rotary joint mechanism 6 such that the axis (X) of the face plate unit 5 is substantially parallel to the sole surface 420, and the face plate unit 5 is capable of being rotated to make one of the three faces 50 fill in the opening 410 to serve as the putting face.

[0044] According to the design of the golf putter head, the shape of the face plate unit 5 can be substituted by other polyhedrons such as an irregular triangular prism, a quadrangular prism (or a square prism), a pentagonal prism (or a regular pentagonal prism), etc.

[0045] In this preferred embodiment, the face plate unit 5 has a main body 51 and three face plates 52 that are additionally and respectively mounted to the main body 51 to serve as the putting face when putting. In other words, each of the three faces 50 of the face plate unit 5 is formed to have a recess 510 and has a face plate 52 filled in the recess 510. Each of the face plates 52, according to a required property thereof, can be made of aluminum, iron, titanium, acrylonitrile butadiene styrene (ABS), or any suitable materials.

[0046] However, in other preferred embodiments, it is also possible that each face 50 of the face plate unit 5 is treated distinctly to directly serve as the putting face without the need to provide the face plate 52. That is to say, in this case, each of the three faces 50 for putting is integrated with the face plate unit 5 and is not formed on the face plate 52.

[0047] The rotary joint mechanism 6 of the first embodiment includes a pair of axial holes 61 and a pair of shaft members 62 that are received in the pair of axial holes 61, respectively. As shown in FIG. 3, the axial holes 61 are respectively formed in the left and right inner walls 413, 414 on left and right sides of the opening 410. The shaft members 62 are respectively provided on the left and right end faces 53, 54 of the face plate unit 5. Accordingly, the axial holes 61 and the shaft members 62 are rotatably coupled along a direction substantially parallel to the sole surface 420, and are rotatably coupled between the left and right inner walls 413, 414, and the left and right end faces 53, 54 of the face plate unit 5.

[0048] Moreover, the axial holes 61 and the shaft members 62 are rotatably coupled to permit movement of the face plate unit 5 between a locked position and an unlocked position. Each of the axial holes 61 (not shown in FIGS. 3, 4, 5(a) and 5(b), but shown in FIG. 12) is a long hole extending along a direction perpendicular to the putting face. Each of the shaft members 62 is inserted into a respective one long hole so as to be moveable between the locked position and the unlocked position. In detail, as shown in FIG. 5(a), when the shaft members 62 are disposed in the locked position, the face 50 of the face plate unit 5 serving as the putting face is engaged by the inner walls 411, 412, 413, 414 of the opening 410 so as to

keep the face plate unit 5 from rotating. As shown in FIG. 5(b), when the shaft members 62 are moved to the unlocked position, the face plate unit 5 is shifted to be free from engagement with the inner walls 411, 412, 413, 414 so as to be freely rotatable.

[0049] In this preferred embodiment, with the axial holes 61 and the shaft members 62 rotatably coupled in such manner, the replacement of the original face plate 52 can be simply conducted, without using tools, as follows: moving the shaft members 62 from the locked position to the unlocked position, then rotating the face plate unit 5 about the axis (X) to replace the original face plate 52 by another face plate 52, followed by moving the shaft members 62 from the unlocked position back to the locked position.

[0050] In addition, since the face plate unit 5 is in the locked position when putting the golf ball on the green, and since the putting force is relatively weak, the face plate unit 5 will not rotate by virtue of the putting force, and the shaft members 62 will not be moved to the unlocked position.

[0051] FIG. 6 illustrates the second embodiment of the golf putter head 3 of this invention. The second embodiment differs from the first embodiment only in that the mounting part 41 of the head body 4 includes lower, left and right inner walls 412, 413, 414 of the first embodiment, and is further formed with an upper opening 415 facing the lower inner wall 412, such that the opening 410 is surrounded by the lower, left and right inner walls 412, 413, 414 and the face plate unit 5 is exposed upwardly from the upper opening 415.

[0052] FIG. 7 illustrates the third embodiment of the golf putter head 3 of this invention. The third embodiment differs from the first embodiment only in that the mounting part 41 of the head body 4 includes upper, left and right inner walls 411, 413, 414 of the first embodiment, and is further formed with a lower opening 416 facing the upper inner wall 411, such that the opening 410 is surrounded by the upper, left and right inner walls 411, 413, 414, and the face plate unit 5 is exposed downwardly from the lower opening 416.

[0053] FIGS. 8 and 9 illustrate the fourth embodiment of the golf putter head 3 of this invention. The fourth embodiment differs from the first embodiment only in that the mounting part 41 of the head body 4 includes left and right inner walls 413, 414 of the first embodiment, and is further formed with the upper opening 415 of the second embodiment and the lower opening 416 of the third embodiment.

[0054] FIG. 10 illustrates the fifth embodiment of the golf putter head 3 of this invention. The fifth embodiment differs from the first embodiment only in that each of the three faces 50 is fully covered by one of the face plates 52.

[0055] FIGS. 11 to 13 illustrate the sixth embodiment of the golf putter head 3 of this invention.

[0056] The golf putter head 3 of this embodiment, like the first to the fifth embodiments, includes the head body 4, the face plate unit 5, and the rotary joint mechanism 6. However, the axis (X) of the face plate unit 5 is not parallel to the sole surface 420, but is perpendicular to the sole surface 420. Thus, the face plate unit 5 of this embodiment includes a plurality of faces 50 (three faces) surrounding the axis (X) thereof, and upper and lower end faces 55, 56 connecting with upper and lower sides of the plurality of faces 50 (three faces), respectively.

[0057] Furthermore, the rotary joint mechanism 6 of the sixth embodiment includes an axial hole 61 and a shaft member 62 that is received in the axial hole 61. As shown in FIG. 12, the axial hole 61 is a long hole formed in the upper inner

wall 411 on the upper side of the opening 410. The shaft member 62 is provided on the upper end face 55 of the face plate unit 5. Accordingly, the axial hole 61 and the shaft member 62 are rotatably coupled along a direction substantially perpendicular to the sole surface 420, and are rotatably coupled between the upper inner wall 411, and the upper end face 55 of the face plate unit 5.

[0058] FIG. 14 illustrates the seventh embodiment of the golf putter head 3 of this invention. The seventh embodiment differs from the sixth embodiment only in the configuration of the rotary joint mechanism 6 and in that the upper inner wall 411 on the upper side of the opening 410 is formed with a receiving hole 417.

[0059] The axial hole 61 of the rotary joint mechanism 6 is formed in the upper end face 55 of the face plate unit 5. The shaft member 62 of the rotary joint mechanism 6 has a ball part 621 and a spring part 622. The ball part 621 is received in the axial hole 61 and has one end protruding from the axial hole 61. The spring part 622 is received in the receiving hole 417 and has one end protruding from the receiving hole 417 to press against the ball part 621. Accordingly, the axial hole 61 and the shaft member 62 are rotatably coupled along a direction substantially perpendicular to the sole surface 420, and are rotatably coupled between the upper inner wall 411, and the upper end face 55 of the face plate unit 5.

[0060] Furthermore, the axial hole 61 and the shaft member 62 are rotatably coupled in a normal unlocked position, not in a locked position. Therefore, the replacement of the original face plate 52 can be simply conducted by rotating the face plate unit 5 about the axis (X) (i.e., rotating the face plate unit 5 about the axial hole 61) to replace the original face plate 52 by another face plate 52. That is to say, there is no need to move the shaft members 62 between a locked position and an unlocked position in this embodiment.

[0061] FIGS. 15 and 16 illustrate the eighth embodiment of the golf putter head 3 of this invention.

[0062] The golf putter head 3 of this embodiment comprises the head body 4, the face plate unit 5, the rotary joint mechanism 6, and a fixing member 7. The head body 4 in this embodiment includes a plate part 43 having upper and lower surfaces 431, 432, and a covering part 44 for covering the face plate unit 5 from a back side that is facing the front side of the head body 4.

[0063] Furthermore, the face plate unit 5 is rotatably coupled to the lower surface 432 of the plate part 43 by the rotary joint mechanism 6. The rotary joint mechanism 6 includes an axial hole 61 and a shaft member 62 that is received in the axial hole 61. The axial hole 61 is a through hole formed in the plate part 43. The shaft member 62 is a projection formed on the upper end face 55 that is adjacent to the plate part 43 of the head body 4. The projection of the shaft member 62 is rotatably inserted into the axial hole 61 and is temporarily fixed by the fixing member 7. In this embodiment, the projection is a shaft with a threaded end, and the fixing member is a screw nut.

[0064] The other components of the golf putter head 3 of the eighth embodiment are the same as those of the sixth embodiment.

[0065] In this preferred embodiment, with the axial hole 61 and the shaft member 62 rotatably coupled in such manner, the replacement of the original face plate 52 can be simply conducted, without using tools, as follows: loosening the fixing member (nut) 7 by hand, then rotating the face plate

unit 5 about the axis (X) to replace the original face plate 52 by another face plate 52, followed by tightening the fixing member 7.

[0066] FIGS. 17 and 18 illustrate the ninth embodiment of the golf putter head 3 of this invention. The ninth embodiment differs from the eighth embodiment only in that the head body 4 is the plate part 43 having upper and lower surfaces 431, 432, that the face plate unit 5 is rotatably coupled to the upper surface 431 of the plate part 43 by the rotary joint mechanism 6, and that the shaft member 62 is a projection formed on the lower end face 56 which is adjacent to the plate part 43 of the head body 4.

[0067] FIG. 19 illustrates the tenth embodiment of the golf putter head 3 of this invention. The tenth embodiment differs from the sixth embodiment only in that the golf putter head 3 further includes a fixing member (nut) 7, that the axial hole 61 is a through hole formed in the upper inner wall 411 on the upper side of the opening 410, and the shaft member 62 is a projection formed on the upper end face 55 of the face plate unit 5, and that the projection of the shaft member 62 is rotatably inserted into the axial hole 61 and is temporarily fixed by the fixing member 7.

[0068] FIG. 20 illustrates the eleventh embodiment of the golf putter head 3 of this invention. The eleventh embodiment differs from the sixth embodiment only in that the golf putter head 3 further includes a fixing member (nut) 7, that the axial hole 61 is a through hole formed in the lower inner wall 412 on the lower side of the opening 410, and the shaft member 62 is a projection formed on the lower end face 56 of the face plate unit 5, and that the projection of the shaft member 62 is rotatably inserted into the axial hole 61 and is temporarily fixed by the fixing member 7.

[0069] FIGS. 21 and 22 illustrate the twelfth embodiment of the golf putter head 3 of this invention. The head body 4 of the golf putter head 3 of the twelfth embodiment is \supset -shaped when viewed laterally. The \supset -shaped head body 4 includes two flat portions and a straight portion connecting the two flat portions.

[0070] In this embodiment, the front side of the head body 4, which is formed with the opening 410, serves as the aforesaid mounting part 41. The back side of the head body 4 that includes the straight portion serving as the aforesaid base part 42.

[0071] In other words, the mounting part 41 of this embodiment is formed with the opening 410 from the front side thereof and is constructed to have one section of the aforesaid sole surface 420. The base part 42 is constructed to have the other section of the sole surface 420.

[0072] The mounting part 41 is formed with upper and lower inner walls 411, 412 that surround the opening 410 and that are substantially parallel to the sole surface 420.

[0073] The face plate unit 5 is rotatably coupled to the head body 4 by the rotary joint mechanism 6 such that the axis (X) of the face plate unit 5 is substantially perpendicular to the sole surface 420. The face plate unit 5 is rotated to make one of the three faces 50 fill in the opening 410 to serve as the putting face.

[0074] The rotary joint mechanism 6 of the twelfth embodiment includes a pair of axial holes 61 and a pair of shaft members 62 that are received in the pair of axial holes 61, respectively. The axial holes 61 are respectively formed in the upper and lower inner walls 411, 412 of the head body 4. The shaft members 62 are respectively provided on the upper and lower end faces 55, 56 of the face plate unit 5. Accordingly,

the axial holes 61 and the shaft members 62 are rotatably coupled along a direction substantially perpendicular to the sole surface 420, and are rotatably coupled between the upper and lower inner walls 411, 412, and the upper and lower end faces 55, 56 of the face plate unit 5. Moreover, in this embodiment, the axial hole 61 and the shaft member 62, as the seventh embodiment, are rotatably coupled in a normal unlocked position, not in a locked position. Therefore, the replacement of the original face plate 52 can be simply conducted by rotating the face plate unit 5 about the axis (X) to replace the original face plate 52 by another face plate 52.

[0075] With the golf putter head 3 of the present invention, the replacement of the face plates 52 can be conducted without using tools, and there is no risk of misplacing those face plates 52 since all of the face plates 52 are mounted on the golf putter head 3.

[0076] While the present invention has been described in connection with what are considered the most practical and preferred embodiments, it is understood that this invention is not limited to the disclosed embodiments but is intended to cover various arrangements included within the spirit and scope of the broadest interpretations and equivalent arrangements.

What is claimed is:

1. A golf putter head, comprising a head body, and a face plate unit disposed on said head body and having one surface to serve as a putting face;
 - wherein said face plate unit has a plurality of faces surrounding an axis thereof and is rotatably coupled to said head body so that said face plate unit is rotatable about the axis to make one of said faces of said face plate unit serve as said putting face.
2. The golf putter head of claim 1, wherein said head body includes a plate part having upper and lower surfaces, said golf putter head further comprising a rotary joint mechanism by which said face plate unit is rotatably coupled to one of said upper and lower surfaces of said plate part, said rotary joint mechanism including a shaft member, which is provided on one of said head body and said face plate unit, and an axial hole, which is formed in another one of said head body and said face plate unit and is for receiving said shaft member.
3. The golf putter head of claim 2, wherein:
 - said face plate unit further has upper and lower end faces connecting with upper and lower sides of said plurality of faces, respectively;
 - said axial hole is a through hole formed in said head body;
 - said shaft member is a projection formed on one of said upper and lower end faces of said face plate unit, which is adjacent to said head body; and
 - said projection is rotatably inserted into said through hole and is temporarily fixed.
4. The golf putter head of claim 1, wherein each of said plurality of faces of said face plate unit is provided with a face plate.
5. The golf putter head of claim 1, wherein each of said plurality of faces of said face plate unit is formed to have a recess and has a face plate filled in said recess.
6. A golf putter head, comprising:
 - a head body formed with an opening from a front side thereof, said front side being adapted for facing toward a golf ball when putting; and
 - a face plate unit with one surface filled in said opening of said head body to serve as a putting face of said golf putter head;

wherein said face plate unit has a plurality of faces surrounding an axis thereof and is rotatably coupled to said head body so that said face plate unit is rotatable about the axis to make one of said faces of said face plate unit serve as said putting face.

7. The golf putter head of claim 6, further comprising a rotary joint mechanism, by which said face plate unit is rotatably coupled to said head body, wherein said rotary joint mechanism includes a shaft member, which is provided on one of said head body and said face plate unit, and an axial hole, which is formed in another one of said head body and said face plate unit and is for receiving said shaft member.

8. The golf putter head of claim 7, wherein said head body has a sole surface to function as a sole when putting, and said axial hole and said shaft member are rotatably coupled along a direction substantially parallel to said sole surface.

9. The golf putter head of claim 8, wherein: said head body is further formed with upper, lower, left and right inner walls that surround said opening, said upper and lower inner walls being substantially parallel to said sole surface, said left and right inner walls being substantially perpendicular to said sole surface; said face plate unit further has left and right end faces connecting with left and right sides of said plurality of faces, respectively, and is rotatably coupled to said head body such that the axis is substantially parallel to said sole surface; and

said axial hole and said shaft member are rotatably coupled between at least one of said left and right inner walls and at least a respective adjacent one of said left and right end faces.

10. The golf putter head of claim 8, wherein: said head body includes lower, left and right inner walls, and is further formed with an upper opening facing said lower inner wall, such that said opening is surrounded by said lower, left and right inner walls and said face plate unit is exposed upwardly from said upper opening, said lower inner wall being substantially parallel to said sole surface, said left and right inner walls being substantially perpendicular to said sole surface; said face plate unit further has left and right end faces connecting with left and right sides of said plurality of faces, respectively, and is rotatably coupled to said head body such that the axis is substantially parallel to said sole surface; and

said axial hole and said shaft member are rotatably coupled between at least one of said left and right inner walls and at least a respective adjacent one of said left and right end faces.

11. The golf putter head of claim 8, wherein: said head body includes upper, left and right inner walls, and is further formed with a lower opening facing said

upper inner wall, such that said opening is surrounded by said upper, left and right inner walls and said face plate unit is exposed downwardly from said lower opening, said upper inner wall being substantially parallel to said sole surface, said left and right inner walls being substantially perpendicular to said sole surface;

said face plate unit further has left and right end faces connecting with left and right sides of said plurality of faces, respectively, and is rotatably coupled to said head body such that the axis is substantially parallel to said sole surface; and

said axial hole and said shaft member are rotatably coupled between at least one of said left and right inner walls and at least a respective adjacent one of said left and right end faces.

12. The golf putter head of claim 7, wherein said head body has a sole surface to function as a sole when putting, and said axial hole and said shaft member are rotatably coupled along a direction substantially perpendicular to said sole surface.

13. The golf putter head of claim 12, wherein: said head body is further formed with upper, lower, left and right inner walls that surround said opening, said upper and lower inner walls being substantially parallel to said sole surface, said left and right inner walls being substantially perpendicular to said sole surface;

said face plate unit further has upper and lower end faces connecting with upper and lower sides of said plurality of faces, respectively, and is rotatably coupled to said head body such that the axis is substantially perpendicular to said sole surface; and

said axial hole and said shaft member are rotatably coupled between at least one of said upper and lower inner walls and at least a respective adjacent one of said upper and lower end faces.

14. The golf putter head of claim 7, wherein said axial hole and said shaft member are rotatably coupled to permit movement of said face plate unit between a locked position, where said one of said faces of said face plate unit serving as said putting face is engaged by an inner wall surrounding said opening so as to keep said face plate unit from rotating, and an unlocked position, where said face plate unit is shifted from said locked position so as to be freely rotatable.

15. The golf putter head of claim 14, wherein said axial hole is a long hole, and said shaft member is inserted into said long hole so as to be moveable between said locked position and said unlocked position.

16. The golf putter head of claim 15, further comprising a fixing member for temporarily fixing said shaft member in said locked position.

* * * * *