



US 20130260912A1

(19) **United States**

(12) **Patent Application Publication**

Jertson et al.

(10) **Pub. No.: US 2013/0260912 A1**

(43) **Pub. Date: Oct. 3, 2013**

(54) **GOLF CLUB HEADS AND METHODS OF MANUFACTURING GOLF CLUB HEADS**

Publication Classification

(75) Inventors: **Marty R. Jertson**, Phoenix, AZ (US);
David L. Petersen, Peoria, AZ (US)

(51) **Int. Cl.**
A63B 53/04 (2006.01)
B23Q 11/00 (2006.01)

(73) Assignee: **KARSTEN MANUFACTURING CORPORATION**, Phoenix, AZ (US)

(52) **U.S. Cl.**
USPC **473/330; 409/131**

(21) Appl. No.: **13/476,834**

(22) Filed: **May 21, 2012**

(57) **ABSTRACT**

Related U.S. Application Data

(60) Provisional application No. 61/619,901, filed on Apr. 3, 2012.

A golf club head with grooves is described herein. Other embodiments are disclosed.

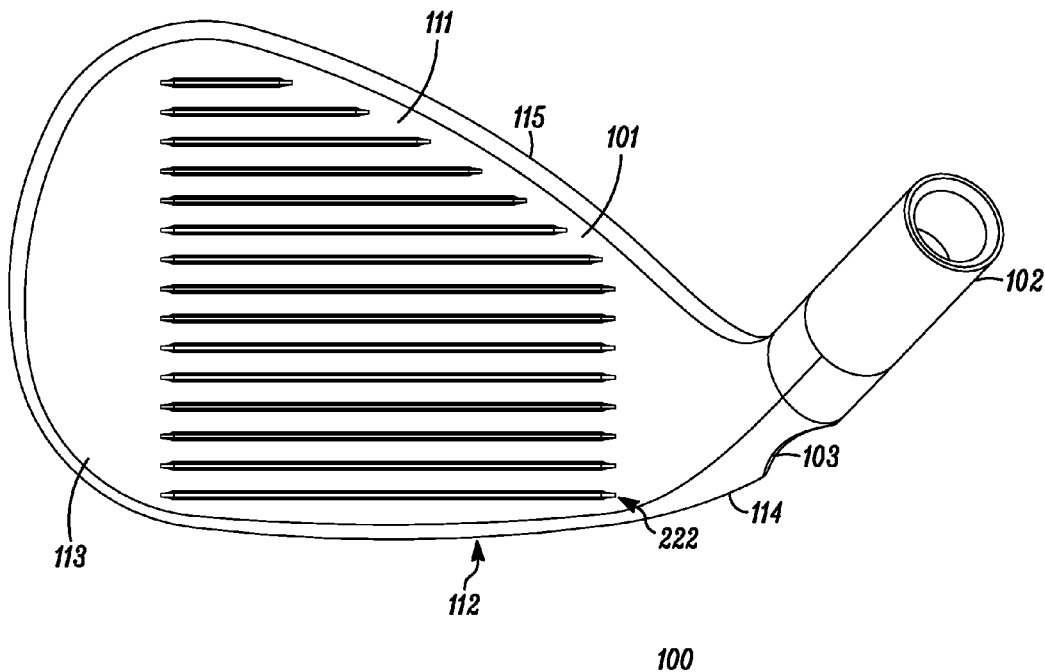

100

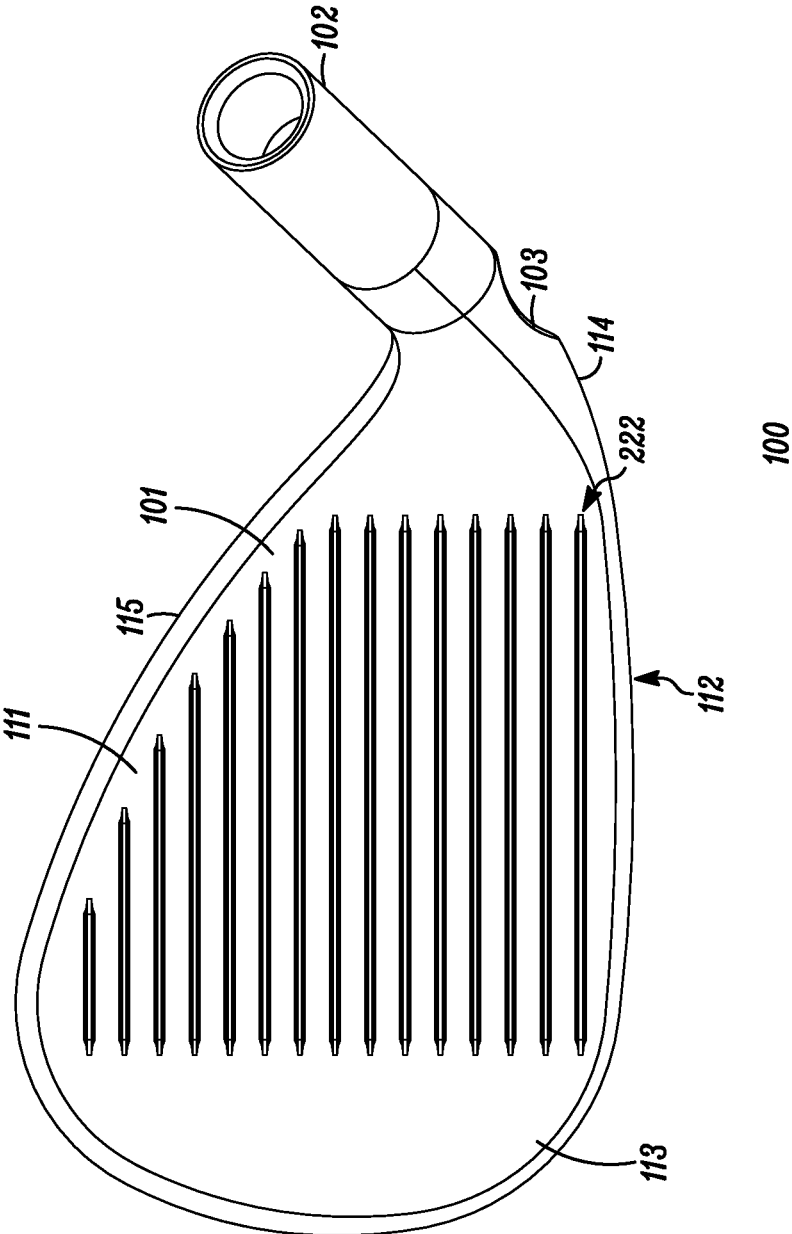
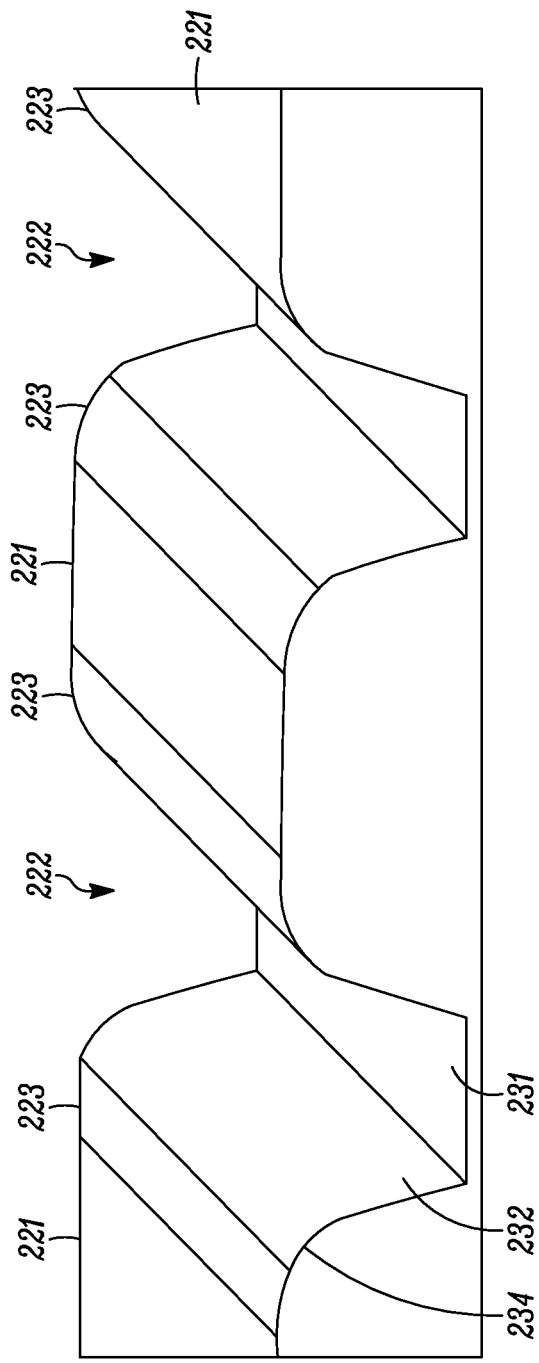
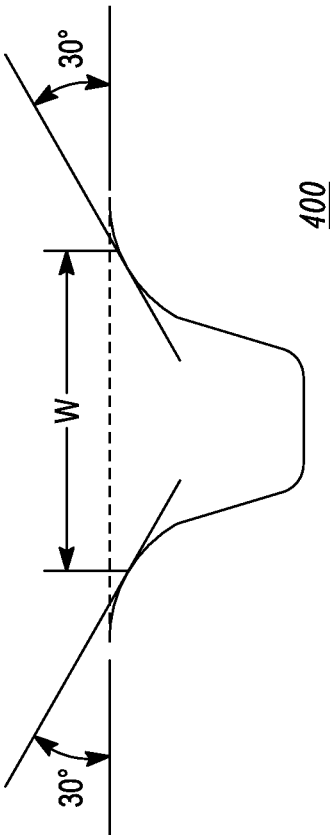

FIG. 1



111

FIG. 2



(PRIOR ART)
FIG. 4

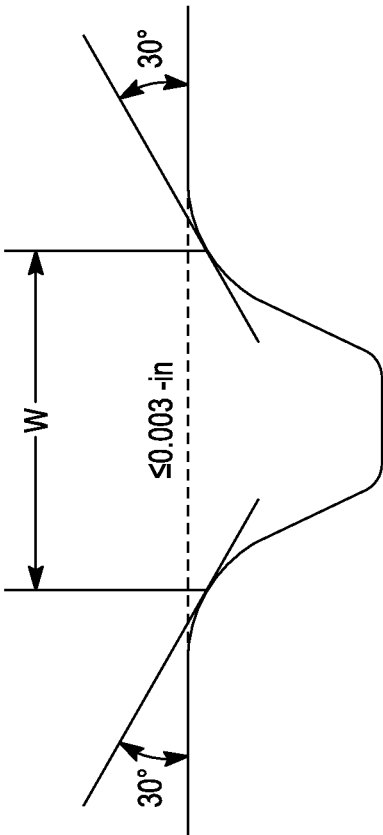

(PRIOR ART)
FIG. 5

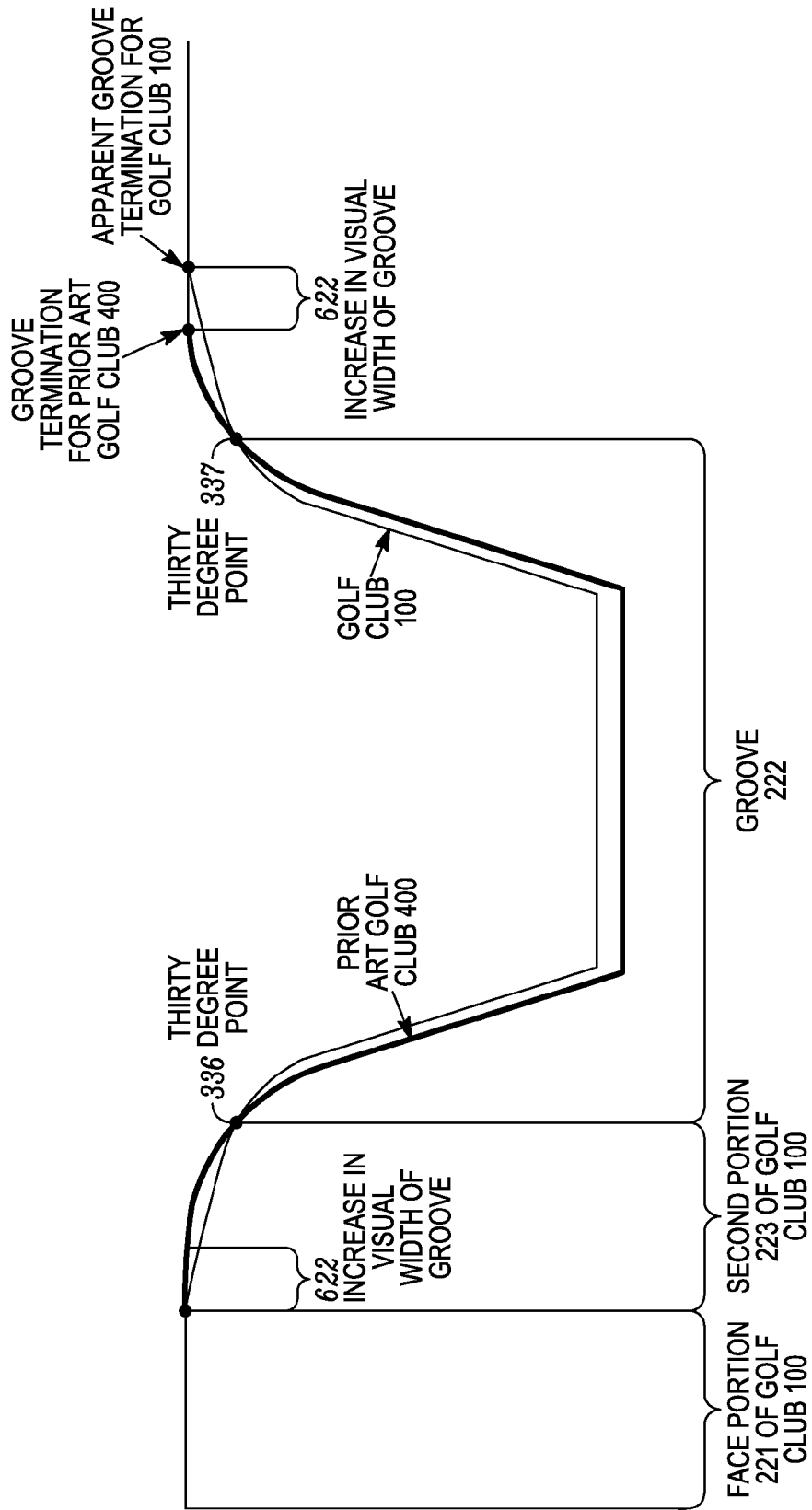

FIG. 6

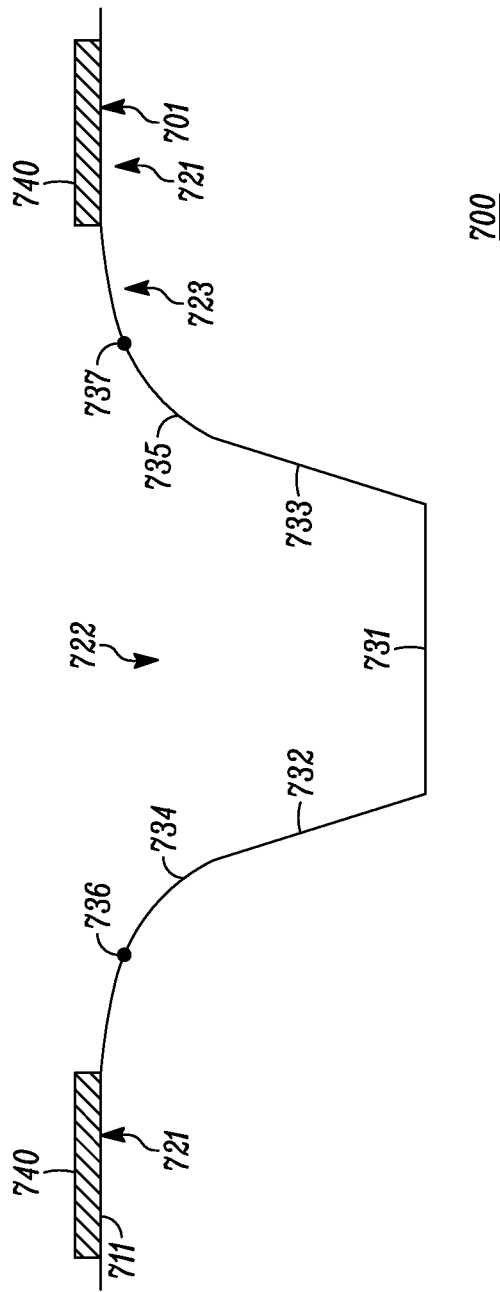
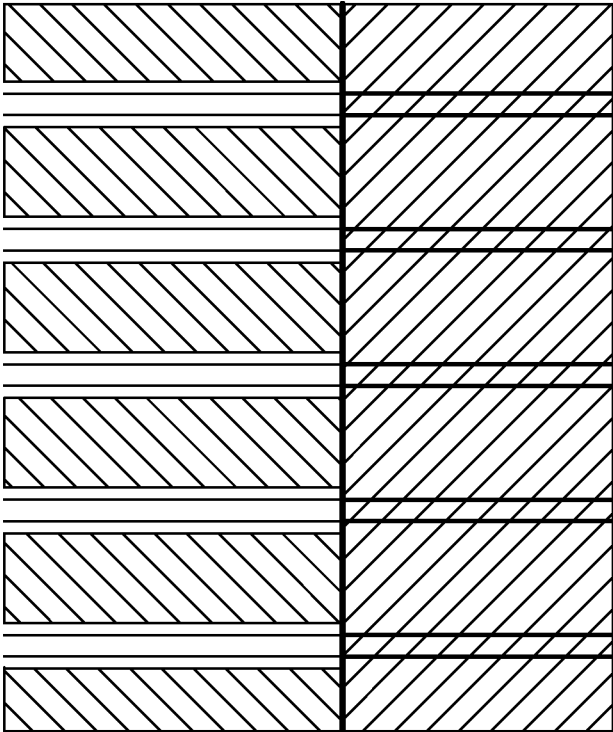

FIG. 7



GROOVES OF GOLF CLUB 700 (APPEARS MUCH WIDER)

PRIOR ART GROOVE (APPEARS NARROWER)

FIG. 8

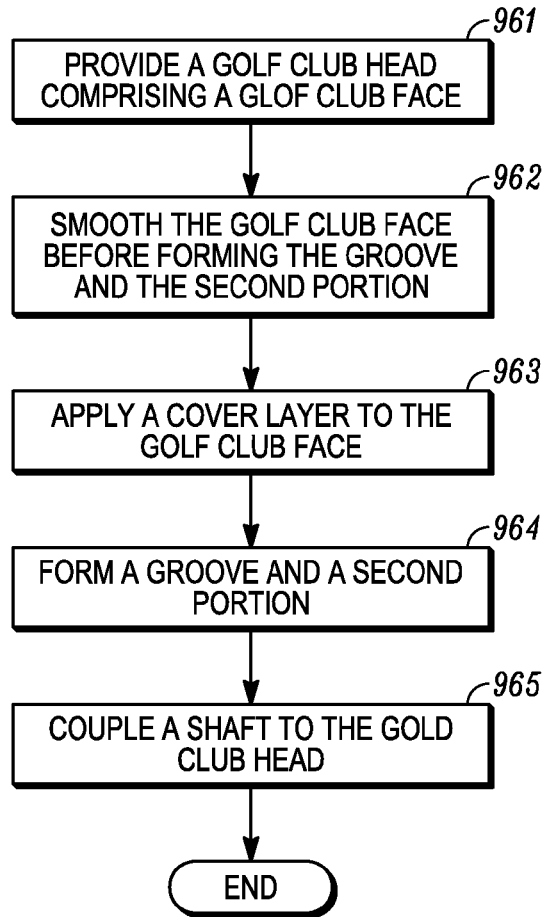

FIG. 9

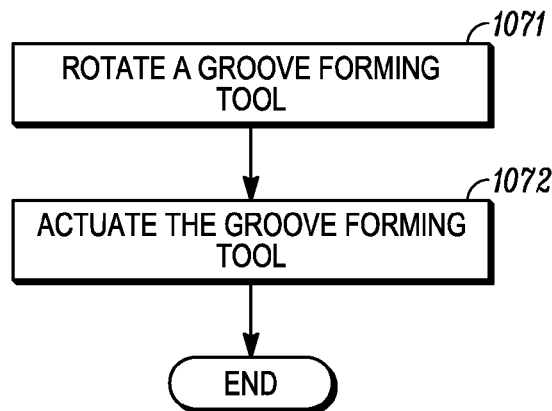

FIG. 10

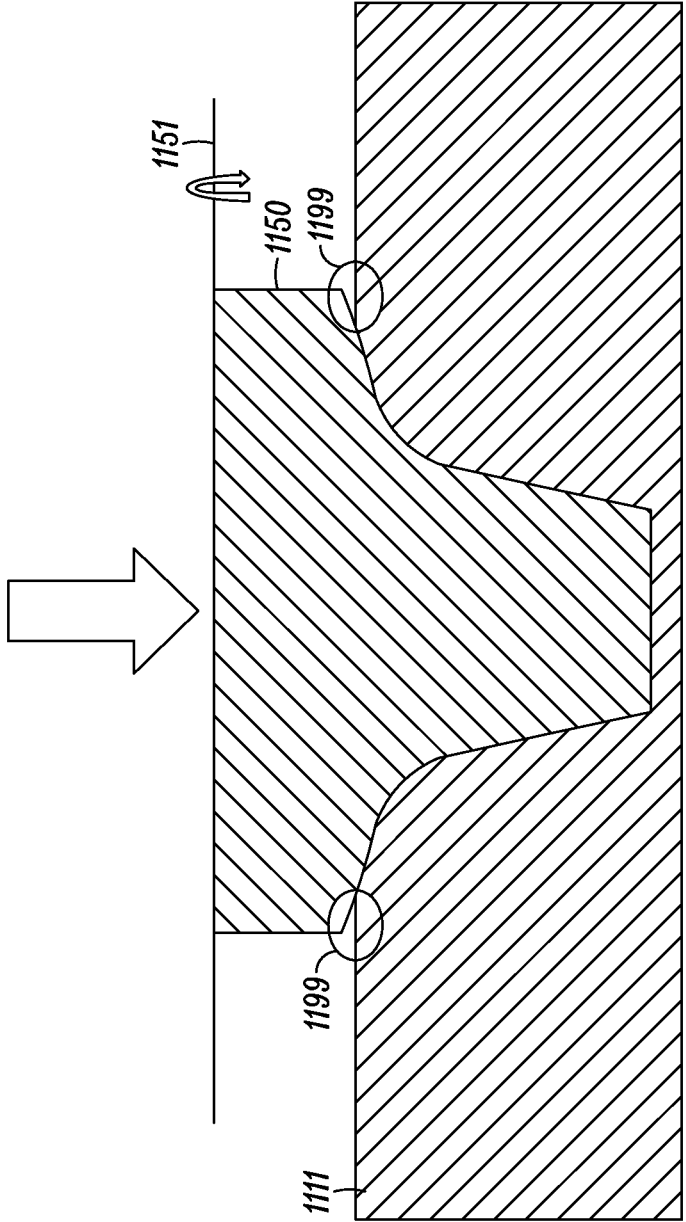

FIG. 11

ANGLE OF SECOND PORTION WITH FACE PORTION	15°	12°
PLUNGE DEPTH RANGE	RESPECTIVE VISUAL WIDTHS	
	UPPER LIMIT (+0.001in.; 0.003cm)	0.048 in. (0.122 cm)
	SET PLUNGE DEPTH (±0.000in.; 0.0cm)	0.040 in. (0.102 cm)
	LOWER LIMIT (-0.001in.; -0.003cm)	0.033 in. (0.083 cm)
VARIANCE OF VISUAL WIDTH	0.015 in. (0.038 cm)	0.018 in. (0.046 cm)

FIG. 12

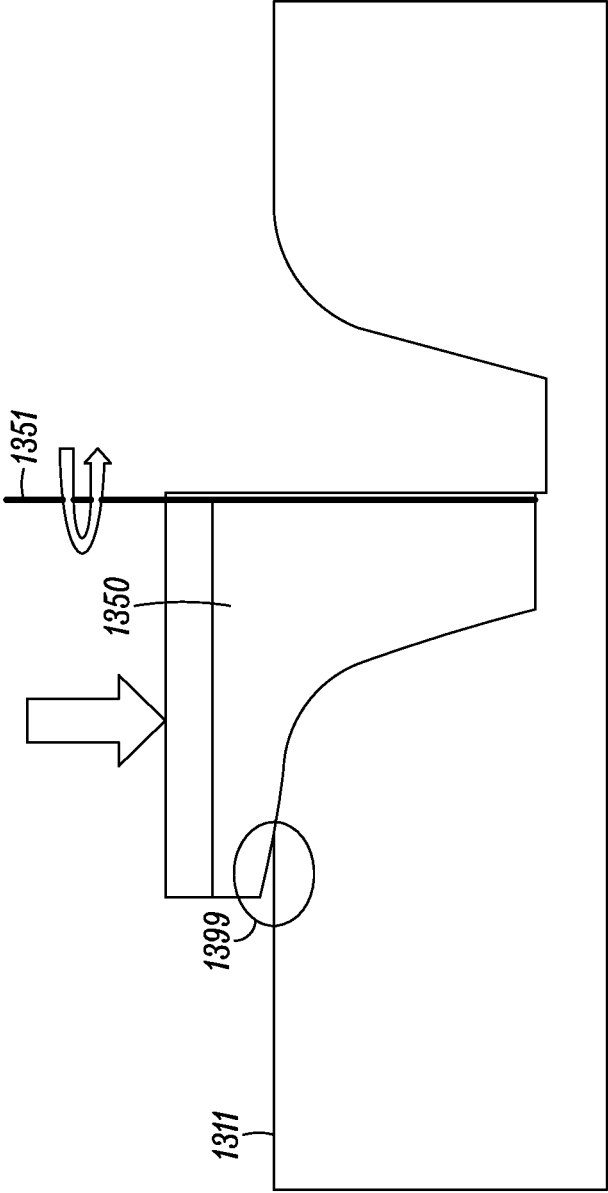

FIG. 13

GOLF CLUB HEADS AND METHODS OF MANUFACTURING GOLF CLUB HEADS

CROSS-REFERENCE TO RELATED APPLICATIONS

[0001] This application claims the benefit of U.S. Provisional Application No. 61/619,901, filed Apr. 3, 2012. U.S. Provisional Application No. 61/619,901 is incorporated herein by reference.

TECHNICAL FIELD

[0002] This disclosure relates generally to golf clubs, and relates more particularly to golf club heads having grooves.

BACKGROUND

[0003] In general, a golf club includes a club face with grooves in order to increase the frictional force at impact between the club face and the ball. The United States Golf Association (USGA) publishes and maintains the Rules of Golf, which govern professional golf in the United States. Appendix II to the USGA Rules provides several limitations on the grooves for golf clubs, including limitations on symmetry, width, depth, edge radius, and relative distance between grooves. The Royal and Ancient Golf Club of St. Andrews, which is the governing authority for the rules of professional golf outside the United States, provides similar limitations to golf club design.

[0004] Moreover, an accurate hitting stroke is accomplished through a variety of subjective, as well as objective, golf club features. For example, many people subjectively associate smaller grooves with decreased ball spin at impact and with shorter distances after impact.

BRIEF DESCRIPTION OF THE DRAWINGS

[0005] To facilitate further description of the embodiments, the following drawings are provided in which:

[0006] FIG. 1 illustrates a top view of a golf club, according to a first embodiment;

[0007] FIG. 2 illustrates an isometric cross-sectional view of a first part of the club face of the golf club of FIG. 1, according to the first embodiment;

[0008] FIG. 3 illustrates a cross-sectional view of a second part of the club face of the golf club of FIG. 1, according to the first embodiment;

[0009] FIG. 4 illustrates an annotated cross-sectional view of a prior art golf club;

[0010] FIG. 5 illustrates a second annotated cross-sectional view of a prior art golf club;

[0011] FIG. 6 illustrates an example of a cross-sectional view of the second part of club face of the golf club of FIG. 1 superimposed over a part of a prior art club face;

[0012] FIG. 7 illustrates a cross-sectional view of a second portion of a club face of a golf club, according to a second embodiment;

[0013] FIG. 8 illustrates a comparison of the grooves of the golf club of FIG. 7 with the groove of a prior art golf club;

[0014] FIG. 9 illustrates a flow chart for an exemplary embodiment of a method of manufacturing a golf club, according to an embodiment;

[0015] FIG. 10 illustrates a flow chart for an exemplary embodiment of an activity of forming a groove and a second portion at the golf club face, according to an embodiment;

[0016] FIG. 11 illustrates an example of a groove cutting tool forming a groove;

[0017] FIG. 12 illustrates a chart of exemplary values for use with the groove cutting tool of FIG. 11; and

[0018] FIG. 13 illustrates a second example of a groove cutting tool forming a groove.

[0019] For simplicity and clarity of illustration, the drawing figures illustrate the general manner of construction, and descriptions and details of well-known features and techniques may be omitted to avoid unnecessarily obscuring the invention. Additionally, elements in the drawing figures are not necessarily drawn to scale. For example, the dimensions of some of the elements in the figures may be exaggerated relative to other elements to help improve understanding of embodiments of the present invention. The same reference numerals in different figures denote the same elements.

[0020] The terms “first,” “second,” “third,” “fourth,” and the like in the description and in the claims, if any, are used for distinguishing between similar elements and not necessarily for describing a particular sequential or chronological order. It is to be understood that the terms so used are interchangeable under appropriate circumstances such that the embodiments described herein are, for example, capable of operation in sequences other than those illustrated or otherwise described herein. Furthermore, the terms “include,” and “have,” and any variations thereof, are intended to cover a non-exclusive inclusion, such that a process, method, system, article, device, or apparatus that comprises a list of elements is not necessarily limited to those elements, but may include other elements not expressly listed or inherent to such process, method, system, article, device, or apparatus.

[0021] The terms “left,” “right,” “front,” “back,” “top,” “bottom,” “over,” “under,” and the like in the description and in the claims, if any, are used for descriptive purposes and not necessarily for describing permanent relative positions. It is to be understood that the terms so used are interchangeable under appropriate circumstances such that the embodiments of the invention described herein are, for example, capable of operation in other orientations than those illustrated or otherwise described herein.

[0022] The terms “couple,” “coupled,” “couples,” “coupling,” and the like should be broadly understood and refer to connecting two or more elements or signals, electrically, mechanically and/or otherwise.

DESCRIPTION

[0023] In some embodiments, a golf club head can include: a club face to engage a golf ball, the club face having: a face portion; at least one groove in the club face, the at least one groove having a bottom, a first side wall adjacent to the bottom, a second side wall adjacent to the bottom, a first top radius adjacent to the first side wall, and a second top radius adjacent to the second side wall; and a second portion located between the face portion and a top of the at least one groove, the second portion is a substantially flat plane at a first angle with the face portion. The first angle can be between approximately eight and eighteen degrees relative to the face portion. The at least one groove is compliant with a Thirty Degree Rule when measured from the first top radius and the second top radius.

[0024] In different embodiments, a golf club can include: a golf club head having: a strike face having: a face portion; one or more channels with a first sidewall and a second sidewall, the first sidewall comprises a first thirty degree point and the

second sidewall comprises a second thirty degree point; a first angled surface between the first degree point and the face portion and also between the second thirty degree points and the face portion; and a cover layer located over the face portion; and a shaft coupled to the golf club head. The face portion can be substantially flat. Each of the one or more channels can be symmetric. The first angled surface is at an eight to eighteen degree angle relative to the face portion. The cover layer has a first reflectivity and the one or more channels has a second reflectivity. The first reflectivity is different from the second reflectivity; and the first angled surface and the one or more channels are devoid of being covered by the cover layer.

[0025] In further embodiments, a method for manufacturing a golf club head including: providing a golf club head comprising a golf club face; and forming a groove and a second portion at the golf club face, forming the groove and the second portion including: rotating a groove forming tool such that the groove forming tool forms: a groove in the golf club face such that the groove is compliant with Thirty Degree Rule when measured from a first top radius of the groove and a second top radius of the groove; and a second portion adjacent to the first top radius and the second top radius of the groove and at a first angle of approximately eight to eighteen degrees relative to the golf club face of the golf club; and actuating the groove forming tool from a first end to a second end of the golf club face.

[0026] Turning to the drawings, FIG. 1 illustrates a top view of golf club 100, according to a first embodiment. Golf club 100 is merely exemplary and is not limited to the embodiments presented herein. Golf club 100 can be employed in many different embodiments or examples not specifically depicted or described herein. Golf club 100 can be an iron-type golf club head, such as a 1-iron, a 2-iron, a 3-iron, a 4-iron, a 5-iron, a 6-iron, a 7-iron, an 8-iron, a 9-iron, a sand wedge, a lob wedge, a pitching wedge, an n-degree wedge (e.g., 44 degrees (°), 48°, 52°, 56°, 60°, etc.), etc. In a different embodiment, golf club 100 can also be a wood-type golf club, a hybrid-type golf club, or a putter-type golf club.

[0027] In some embodiments, golf club 100 can include: (a) a golf club head 101; (b) a shaft 102; and (c) a hosel 103 coupled to shaft 102. In a different embodiment, golf club 100 has a hole, instead of hosel 103, to which shaft 102 is coupled. A first end of shaft 102 and hosel 103 may be secured to each other by an adhesive bonding process (e.g., epoxy) and/or other suitable bonding processes (e.g., mechanical bonding, soldering, welding, and/or brazing). To complete the golf club, a grip (not shown) may receive a second or opposite end of the shaft. The shaft and the grip may be secured to each other by an adhesive bonding process and/or other suitable bonding processes. In some examples, hosel 103 or the hole can be at the heel end of golf club head 101 or at a center of golf club head 101.

[0028] Golf club head 101 can include: (a) a club face 111 (i.e., a strike face) to engage a golf ball, (b) a sole 112 coupled to club face 111; (c) a toe edge 113 coupled to club face 111 and sole 112; (d) a heel edge 114 opposite toe edge 113 and coupled to club face 111 and sole 112; and (e) a top surface 115 (e.g., a top rail) coupled to club face 111, toe edge 113, and heel edge 114.

[0029] In some examples, golf club head 101 can be manufactured from a steel material, another metal, or one or more other materials by a casting process, a forging process, a combination thereof, or one or more other suitable manufac-

turing processes. In many examples, golf club head 101 can be formed as a unitary body. In other examples, golf club head 101 can be made of multiple pieces (e.g., a separate face plate and/or separate inserts to form the grooves).

[0030] FIG. 2 illustrates an isometric cross-sectional view of a first part of club face 111, according to the first embodiment. FIG. 3 illustrates a cross-sectional view of a second part of club face 111, according to the first embodiment.

[0031] As shown in FIGS. 2 and 3, club face 111 can include: (a) a face portion 221; (b) at least one groove 222 (i.e., at least one channel); and (c) a second portion 223 (i.e., an angled surface) located between face portion 221 and groove 222. In various embodiments, face portion 221 is substantially flat. For example, the face portion can be substantially flat to within plus or minus approximately 0.002 inches (0.051 millimeters (mm)).

[0032] Groove 222 can include: (a) a bottom 231; (b) a first side wall 232 adjacent to bottom 231; (c) a second side wall 333 adjacent to bottom 231 and opposite first side wall 232; (d) a first top radius 234 adjacent to first side wall 232; and (e) a second top radius 335 adjacent to second side wall 333 and opposite first top radius 234. In addition, groove 222 can include a first thirty degree point 336 at a top end of first top radius 234 (i.e., between first top radius 234 and first side wall 232) and a second thirty degree point 337 at a top end of second top radius 335 (i.e., between second top radius 335 and second portion 223). First top radius 234 and second top radius 335 are 0.003 inches (0.75 mm) or closer from face portion 221. In some examples, the tangent lines (e.g., tangent line 327) at first thirty degree point 336 and second thirty degree point 337 of first top radius 234 and second top radius 335, respectively, are different from the slopes of first side wall 232 and second side wall 333, respectively.

[0033] In many examples, a distance between first thirty degree point 336 and second thirty degree point 337 is equal to or less than 0.035 inches (0.89 mm). In many examples, each of grooves 222 are symmetric. In many examples, first top radius 234 and/or first thirty degree point 336 can be considered part of first side wall 232. Similarly, second top radius 335 and/or second thirty degree point 337 can be considered part of first side wall 333.

[0034] In many examples, first thirty degree point 336 and second thirty degree point 337 are defined by and compliant with the USGA's thirty degree method for measuring groove width (the "Thirty Degree Rule"). The USGA's Determination of Groove Conformance (Impact Area Markings (App II, 5c) Measurement Procedure) ruling, dated August 2008, is incorporated herein by reference. According to the USGA in its Thirty Degree Rule (i.e., Appendix B of the Determination of Groove Conformance ruling), the groove in a club face starts where there is a significant departure from the plane of the face (land area) (i.e., face portion 221). The Thirty Degree Rule specifies where the measurement of the groove width should be taken when the edges of the grooves are rounded.

[0035] The sidewall of a groove generally meets the face of the club (land area) with a filleted transition. As shown in FIG. 4, under the Thirty Degree Rule, the groove width measurement (W) is made between two points where a line, inclined at thirty degrees to the land area of the club face, is tangent to the edge of the groove. Furthermore, as shown in FIG. 5, if the tangent point using the 30° method occurs at a location that is more than 0.003 in. (0.76 mm) below the land area, then the width measurement shall be made at the points on the groove

that are 0.003 in. (0.76 mm) below the land area. FIGS. 4 and 5 are figures from the USGA Rules of Golf that help define the Thirty Degree Rule.

[0036] Accordingly, referring again to FIGS. 1-3, first thirty degree point 336 and second thirty degree point 337 are the points in groove 222 where a line, inclined at thirty degrees to face portion 221 of club face 111, is tangent to the edge of groove 222.

[0037] Second portion 223 can be located between face portion 221 and a top of groove 222. Second portion 223 can be a substantially flat plane at a first angle 325 with face portion 221. In some examples, first angle 325 is between approximately eight and eighteen degrees relative to face portion 221. In other examples, first angle 325 is between approximately ten and fifteen degrees relative to face portion 221. In still further examples, first angle 325 is approximately ten to eighteen degrees relative to face portion 221. These ranges can maximize visual appearance of the width of the grooves, while not being adversely affected by manufacturing tolerances. In some examples, a length of second portion 223 between face portion 221 and groove 222 can be between approximately 0.002 inches (0.005 centimeters) and 0.047 inches (0.119 centimeters).

[0038] In some examples, first side wall 232 (or, in other examples, first top radius 234) is at a second angle 326 with face portion 221. Second angle 326 is greater than first angle 325.

[0039] Second portion 223 can be adjacent to first top radius 234 and second top radius 335 of groove 222. Specifically, second portion 223 can be adjacent to first top radius 234 at first thirty degree point 336 and second top radius 335 at second thirty degree point 337. Thus, second portion 223 is outside of groove 222, as defined by the Thirty Degree Rule.

[0040] In many examples, second portion 223 can be formed as a flat plane, tangent to first and second top radii 234 and 337 of groove 222. To be conforming to the USGA rules of golf, second portion 223 must be tangent to the top radius of groove 222, and at no more than thirty degrees when measured from face portion 221 of club face 111. In other examples, second portion 223 is not planar. For example, second portion 223 could consist of a larger radius than side walls 232 and 333 and/or top radius 234 and 335. This larger radius of second portion 223 would extend outside of groove 222 from top radius 234 and 335, providing the larger visual width for groove 222. In order for the larger radius to be conforming to the USGA standards, it can start at first thirty degree point 336 and second thirty degree point 337.

[0041] FIG. 6 illustrates an example of a cross-sectional view of the second part of club face 111 superimposed over a part of a prior art club face. As shown in FIG. 6, the use of second portion 223 in addition to groove 222 can create a visual impression to the user of golf club 100 that grooves 222 are larger than prior art grooves by amount 622 while golf club 100 and grooves 222 still comply with the USGA Rules of Golf. Accordingly, because many people associate larger or wider grooves with increased spin at ball impact and also with longer distances after impact, use of golf club 100 can provide an increased psychological benefit to its users and allow the user to hit a golf ball further and with improved accuracy.

[0042] Turning to the drawings, FIG. 7 illustrates a cross-sectional view of a second portion of club face 711 of golf club 700, according to a second embodiment. Golf club 700 is merely exemplary and is not limited to the embodiments

presented herein. Golf club 700 can be employed in many different embodiments or examples not specifically depicted or described herein. Golf club 700 can be an iron-type golf club head, such as a 1-iron, a 2-iron, a 3-iron, a 4-iron, a 5-iron, a 6-iron, a 7-iron, an 8-iron, a 9-iron, a sand wedge, a lob wedge, a pitching wedge, an n-degree wedge (e.g., 44 degrees (°), 48°, 52°, 56°, 60°, etc.), etc. In a different embodiment, golf club 700 can also be a wood-type golf club, a hybrid-type golf club, or a putter-type golf club.

[0043] In some embodiments, golf club 700 can include: (a) a golf club head 701; (b) a shaft 102 (FIG. 1); and (c) a hosel 103 (FIG. 1) coupled to shaft 102. Golf club head 701 can include: (a) club face 711 (i.e., a strike face) to engage a golf ball, (b) a sole 112 (FIG. 1) coupled to club face 711; (c) a toe edge 113 (FIG. 1) coupled to club face 711 and sole 112; (d) a heel edge 114 (FIG. 1) opposite toe edge 113 and coupled to club face 711 and sole 112; (e) a top surface 115 (FIG. 1) (e.g., a top rail) coupled to club face 711, toe edge 113, and heel edge 114.

[0044] As shown in FIG. 7, club face 711 can include: (a) a face portion 721; (b) at least one groove 722; (c) a second portion 723 located between face portion 721 and groove 722; and (d) a cover layer 740 (i.e., a coating) located over at least a portion of face portion 721.

[0045] In various embodiments, face portion 221 is substantially flat. For example, face portion 721 can be substantially flat to within plus or minus approximately 0.002 inches (0.051 mm).

[0046] Groove 722 can include: (a) a bottom 731; (b) a first side wall 732 adjacent to bottom 731; (c) a second side wall 733 adjacent to bottom 731; (d) a first top radius 734 adjacent to first side wall 732; and (e) a second top radius 735 adjacent to second side wall 733. In addition, groove 722 can include a first thirty degree point 736 at an end of first top radius 734 and a second thirty degree point 737 at an end of second top radius 735. As shown in FIG. 7, groove 722 is devoid of cover layer 740 at second portion 723 and within groove 722. In other examples, groove 722 and second portion 723 can have a cover layer that is the same or different from cover layer 740.

[0047] In many examples, a thickness of cover layer 740 is less than 0.001 inches (0.025 mm). In some embodiments, a surface roughness and/or reflectivity of cover layer 740 is different than a surface roughness and/or reflectivity of second portion 723 and/or at least one surface of groove 722. For example, the surface roughness of cover layer 740 can be approximately 20 micro-inches (51 micro-centimeters) to 180 micro-inches (457 micro-centimeters), and the surface roughness of second portion 723 and groove 722 can be approximately 4 micro-inches (10 micro-centimeters), to 40 micro-inches (457 micro-centimeters).

[0048] In the same or different examples, a surface of groove 722 and/or second portion 723 has a first reflectivity, and a surface of face portion 721 can have a second reflectivity. The first reflectivity is different from the second reflectivity. In many embodiments, cover layer 740 can be considered a surface of face portion 721 with cover layer 740 having the second reflectivity.

[0049] As shown in FIG. 7, golf club 700 is comprised of a contrasting finish, and a lead-in design for the grooves. The lead-in design, combined with the contrasting finish, creates an exaggerated “visual width” of the grooves, while the grooves remain entirely conforming to the USGA groove rules.

[0050] The contrasting finish is made up of a first finish (i.e., the lack of cover layer 740) and a “second finish” (i.e., cover layer 740) on club face 711. To manufacture golf club 700, the golf club head is forged or cast without the grooves in club face 711. After several smoothing steps, the golf club head possesses the natural finish of the metal, which is the first finish. Then a coating, or otherwise contrasting second finish, is placed on the golf club head. This contrasting second finish could be a plating, thin film coating, oxidation process, blasting process, or any other method that can, in some examples, create a resilient and thin coating. In many examples, the second finish is a contrasting finish when compared to the first finish that is created on the substrate club head material after the grooves have been machined or otherwise created. The contrasting second finish (i.e., cover layer 740) can be very thin to facilitate the milling of the lead-in design (in some examples, less than 0.001 in. (0.025 mm) thick). Some examples of contrasting finishes are: black-nickel chrome, dark-colored physical vapor deposition (PVD), QPQ (quench polish quench), oil can, satin nickel-chrome, steel shot bead blasting, or ceramic media blasting.

[0051] Referring to FIG. 8, a golf club with a first and second finish and the lead-in groove design is shown side-by-side with a standard finish and standard grooves. In this embodiment, the grooves of golf club 700 appear to be 20% wider than the grooves in the prior art golf club.

[0052] Returning to FIG. 7, in other embodiments, cover layer 740 can be located over face portion 721 and over second portion 723, but not over grooves 722. In still another example, a first cover layer can be located over face portion 721, and a second cover layer can be located over second portion 723. In this embodiment, a third cover layer can be located over at least part of groove 722, or groove 722 can be devoid of a cover layer. In these examples, the first cover layer, the second cover layer, and the third cover layer can have different surface roughnesses and/or reflectivities. That is, the first cover layer, the second cover layer, and the third cover layer can be contrasting finishes.

[0053] FIG. 9 illustrates a flow chart for an embodiment of a method 900 of manufacturing a golf club. Method 900 is merely exemplary and is not limited to the embodiments presented herein. Method 900 can be employed in many different embodiments or examples not specifically depicted or described herein. In some embodiments, the activities, the procedures, and/or the processes of method 900 can be performed in the order presented. In other embodiments, the activities, the procedures, and/or the processes of method 900 can be performed in any other suitable order. In still other embodiments, one or more of the activities, the procedures, and/or the processes in method 900 can be combined or skipped.

[0054] Referring to FIG. 9, method 900 includes an activity 961 of providing a golf club head. For example, the golf club head can be similar or identical to golf club head 101 or 701 of FIGS. 1 and 7, respectively. For example, the golf club head body may be formed, for instance, by casting, forging, cutting, grinding, machining, welding, a combination thereof, or the like.

[0055] In some embodiments, the golf club head can have a face member, a sole, a toe edge coupled to the face member and the sole, a heel edge coupled to the face member and sole and opposite the toe edge, and a top surface coupled to the toe edge.

[0056] Method 900 in FIG. 9 continues with an activity 962 of smoothing the golf club face. In some examples, activity 962 can include performing tumbling, grinding, and/or polishing procedures to the golf club face. In many examples, after activity 962, the golf club face can be very smooth, and the natural finish of the metal of the golf club head can be exposed.

[0057] Subsequently, method 900 of FIG. 9 includes an activity 963 of applying a cover layer to the golf club face. In some examples, the cover layer can be similar to or the same as cover layer 740 of FIG. 7.

[0058] In some examples, the cover layer can be applied using plating, thin film coating, oxidation process, blasting process, or any other method that can create, in some examples, a resilient and thin coating. In various embodiments, the cover layer can be very thin to facilitate the milling of the lead-in design (in some examples less than 0.001 in. (0.025 mm) thick). Some examples of contrasting finishes are: black-nickel chrome, dark-colored physical vapor deposition (PVD), QPQ (quench polish quench), oil can, satin nickel-chrome, steel shot bead blasting, ceramic media blasting. In other embodiments, method 900 does not include an activity 963, and accordingly, no cover layer is applied to the golf club head.

[0059] Next, method 900 of FIG. 9 includes an activity 964 of forming a groove and a second portion at the golf club face. In some examples, the groove can be similar to or the same as groove 222 or 722 of FIGS. 2 and 7, respectively. The second portion can be similar to or the same as second portion 223 or 723 of FIGS. 2 and 7, respectively. FIG. 10 illustrates a flow chart for an exemplary embodiment of activity 964 of forming a groove and a second portion at the golf club face, according to the first embodiment.

[0060] Referring to FIG. 10, activity 964 includes a procedure 1071 of rotating a groove forming tool. In some examples, the groove forming tool can be rotated such that the groove forming tool forms the groove in the golf club face such that the groove is compliant with the Thirty Degree Rule when measured from a first top radius of the groove and a second top radius of the groove. The second portion is adjacent to the first and second top radius of the groove and has a first angle of approximately eight to eighteen degrees relative to a face portion of the golf club.

[0061] In various embodiments, procedure 1071 involves rotating the groove forming tool such that the groove forming tool forms the groove in the golf club face so that a distance between the first thirty degree point and the second thirty degree point is equal to or less than 0.035 in (0.89 mm).

[0062] At least three different embodiments can be used to rotate the groove forming tool. A first example of a groove forming tool 1150 rotating to form the groove is illustrated in FIG. 11. FIG. 11 illustrates a cross section of a lead-in design groove, with the wheel cutter bit inserted into the groove. In this example, groove forming tool 1150 can be a wheel cutter. In this embodiment, a bit spins about an axis 1151 that is parallel to face portion 111. As the bit spins, it scoops out material, creating the lead-in design. The design of the bit creates a conforming groove, while keeping a noticeable visual width. In order to machine a conforming and consistent design, the manufacturing tolerances must be taken into account. When the wheel cutter is lowered into the face portion, the machine's limitations can create a range of plunge

depths. The design of the bit is such that the range of depths will minimally impact the look and conformity of the grooves.

[0063] FIG. 12 illustrates a table showing how the angle of the second portion can affect the impact of the mechanical limitations on the visual width of the groove. By optimizing the second portion's angle relative to the face portion, and taking the range of plunge depths into account, the bit can create consistent and conforming grooves. Referring to FIG. 11, a procedure to optimize the bit is shown schematically in circles 1199; the circles indicate an extended portion of the bit. The bit's extended portion reaches beyond the visual width specifications, while maintaining the same angle with the face portion. FIG. 11 also shows the axis of rotation 1151, and it demonstrates how the bit can be a virtually perfect negative, or opposite of, the lead-in design groove. The bit is lowered into the club face while spinning at a high rate. In this example, the groove forming tool is at an angle perpendicular to the golf club face.

[0064] In other embodiments, instead of machining the second portion of the club face at the same time as the main groove, the second portion could be machined into the club face in a secondary operation. Additional manufacturing methods include etching the second portion into the face of the clubs.

[0065] A second example of a groove forming tool rotating to form the groove in procedure 1071 of FIG. 10 is illustrated in FIG. 13. In the example shown in FIG. 13, groove forming tool 1350 can be a form cutter. In this embodiment, the form cutter spins about an axis 1351 that is perpendicular to face portion 1311 of the club head. As the bit spins, it extracts material under the same principle as an Archimedean Screw pump. A difference between the example in FIG. 11 and this example is the bit. In the example of FIG. 11, the bit is a full negative image of the lead-in groove's negative geometry. In this example of FIG. 13, the bit is a half negative image of the groove's geometry, and as it spins, the bit carves out mirror images of itself on either side of axis of rotation 1351.

[0066] In some examples, this example in FIG. 13 can suffer from the same plunge depth range as the first example. To circumvent this mechanical limitation, the bit can be designed with an extended portion, beyond the visual width design, as shown in circle 1399. This extended portion allows for the plunge depth range to minimally affect the appearance and the consistency of the grooves. In many examples, the bit can be lowered into the club face while spinning at a high rate.

[0067] A third method of manufacture for procedure 1071 combines at least one of the first example of FIG. 11 and the second example of FIG. 13 to carve out a substantially standard groove. Then, a secondary milling step is completed to create the second portion. The first and second examples of FIGS. 11 and 13 require only one milling pass, but it is possible to create the groove with a first milling step, then a second milling step to create the second portion. Other methods than the three described above also can be used to create the groove and the second portion.

[0068] Activity 964 in FIG. 10 continues with a procedure 1072 of actuating the groove forming tool at the angle from a first end to a second end of the golf club face. In many examples, the groove forming tool can be actuated from a first end of the face portion to a second end of the face portion to form a groove (or grooves). In many examples, procedures 1071 and 1072 can be repeated multiple times to create two or more grooves in the face portion. In other examples, the

groove forming tool is designed to form more than one groove in a single pass. After procedure 1072, activity 964 is complete.

[0069] Referring back to FIG. 9, method 900 of FIG. 9 includes an activity 965 of coupling a shaft to the golf club head, wherein a hosel or a hole of the golf club head is configured to accept the shaft. In some examples, the hosel can be coupled to the golf club head body such that the golf club is similar or identical to golf club 100 or 700 of FIGS. 1 and 7, respectively.

[0070] As the rules of golf may change from time to time (e.g., new regulations may be adopted or old rules may be eliminated or modified by golf standard organizations and/or governing bodies), golf equipment related to the methods, apparatus, and/or articles of manufacture described herein may be conforming or non-conforming to the rules of golf at any particular time. Accordingly, golf equipment related to the methods, apparatus, and/or articles of manufacture described herein may be advertised, offered for sale, and/or sold as conforming or non-conforming golf equipment. The methods, apparatus, and/or articles of manufacture described herein are not limited in this regard, unless expressly stated otherwise.

[0071] As explained previously, while the above examples may be described in connection with an iron-type golf club, the apparatus, methods, and articles of manufacture described herein may be applicable to other types of golf club, such as a fairway wood-type golf club, a hybrid-type golf club, an iron-type golf club, a wedge-type golf club, a putter-type golf club, or a driver-type golf club. In other embodiments, the apparatus, methods, and articles of manufacture described herein may be applicable to other type of sports equipment, such as a hockey stick, a tennis racket, a fishing pole, a ski pole, etc.

[0072] Although the invention has been described with reference to specific embodiments, it will be understood by those skilled in the art that various changes may be made without departing from the spirit or scope of the invention. Accordingly, the disclosure of embodiments of the invention is intended to be illustrative of the scope of the invention and is not intended to be limiting. It is intended that the scope of the invention shall be limited only to the extent required by the appended claims. For example, to one of ordinary skill in the art, it will be readily apparent that activities 961-965 of FIG. 9 and procedures 1071 and 1072 of FIG. 10 may be comprised of many different activities and procedures and performed by many different modules, in many different orders; that any element of FIG. 1 may be modified; and that the foregoing discussion of certain of these embodiments does not necessarily represent a complete description of all possible embodiments.

[0073] All elements claimed in any particular claim are essential to the embodiment claimed in that particular claim. Consequently, replacement of one or more claimed elements constitutes reconstruction and not repair. Additionally, benefits, other advantages, and solutions to problems have been described with regard to specific embodiments. The benefits, advantages, solutions to problems, and any element or elements that may cause any benefit, advantage, or solution to occur or become more pronounced, however, are not to be construed as critical, required, or essential features or elements of any or all of the claims, unless such benefits, advantages, solutions, or elements are stated in such claim.

[0074] Moreover, embodiments and limitations disclosed herein are not dedicated to the public under the doctrine of dedication if the embodiments and/or limitations: (1) are not expressly claimed in the claims; and (2) are or are potentially equivalents of express elements and/or limitations in the claims under the doctrine of equivalents.

What is claimed is:

1. A golf club head comprising:

a club face to engage a golf ball, the club face comprising:
a face portion;

at least one groove in the club face, the at least one groove having a bottom, a first side wall adjacent to the bottom, a second side wall adjacent to the bottom, a first top radius adjacent to the first side wall, and a second top radius adjacent to the second side wall; and
a second portion located between the face portion and a top radius of the at least one groove, the second portion is a substantially flat plane at a first angle with the face portion, wherein:

the first angle is between approximately eight and eighteen degrees relative to the face portion; and
the at least one groove is compliant with a Thirty Degree Rule when measured from the first top radius and the second top radius.

2. The golf club head of claim 1, wherein:

a surface of the second portion has a first reflectivity;
a surface of the least one groove has a second reflectivity;
and

the first reflectivity is less than the second reflectivity.

3. The golf club head of claim 1, wherein:

the second portion is adjacent to the first top radius and the second top radius of the at least one groove.

4. The golf club head of claim 3, wherein:

the first top radius comprises a first thirty degree point; and
the second top radius comprises a second thirty degree point.

5. The golf club head of claim 4, wherein:

a distance between the first thirty degree point and the second thirty degree point is equal to or less than 0.035 inches.

6. The golf club head of claim 1, wherein:

the first side wall of the at least one groove is at a second angle with the face portion of the club face; and
the second angle is larger than the first angle.

7. The golf club head of claim 1, wherein:

the first angle is between approximately ten and fifteen degrees relative to the face portion.

8. The golf club head of claim 1, further comprising:

a coating over the face portion;

wherein:

the at least one groove and the second portion are devoid of the coating.

9. The golf club head of claim 8, wherein:

a thickness of the coating is less than 0.001 inches.

10. The golf club head of claim 8, wherein:

a surface roughness of the coating is different than a surface roughness of a surface of the at least one groove.

11. A golf club comprising:

a golf club head comprising

a strike face having:

a face portion;

one or more channels with a first sidewall and a second sidewall, the first sidewall comprises a first thirty degree point relative to the face portion and

the second sidewall comprises a second thirty degree point relative to the face portion;

a first angled surface between the first thirty degree point and the face portion and also between the

second thirty degree point and the face portion; and
a cover layer located over the face portion; and

a shaft coupled to the golf club head,

wherein:

the face portion is substantially flat;

each of the one or more channels is symmetric;

the first angled surface is at an eight to eighteen degree angle relative to the face portion;

the cover layer has a first reflectivity;

the one or more channels have a second reflectivity;

the first reflectivity is different from the second reflectivity; and

the first angled surface and the one or more channels are devoid of being covered by the cover layer.

12. The golf club of claim 11, wherein:

the first angled surface is outside of the one or more channels as defined by the Thirty Degree Rule.

13. The golf club of claim 11, wherein:

the face portion is substantially flat to within plus or minus approximately 0.002 inches.

14. The golf club of claim 11, wherein:

a thickness of the cover layer is less than 0.001 inches.

15. The golf club of claim 11, wherein:

a first one of the first angled surfaces has a length of approximately 0.002 inches to 0.047 inches.

16. A method for manufacturing a golf club head comprising:

providing a golf club head comprising a golf club face; and
forming a groove and a second portion at the golf club face,
forming the groove and the second portion comprising:

rotating a groove forming tool such that the groove forming tool forms:

a groove in the golf club face such that the groove is compliant with a Thirty Degree Rule when measured from a first top radius of the groove and a second top radius of the groove; and

a second portion adjacent to the first top radius and the second top radius of the groove and at a first angle of approximately eight to eighteen degrees relative to the golf club face of the golf club; and

actuating the groove forming tool from a first end to a second end of the golf club face.

17. The method of claim 16, wherein:

rotating the groove forming tool further comprises:

rotating the groove forming tool such that the groove forming tool forms the groove in the golf club face so that the groove is compliant with the Thirty Degree Rule when measured from a first thirty degree point of the first top radius of the groove and a second thirty degree point of the second top radius of the groove, and the groove has a bottom, a first side wall adjacent to the bottom, a second side wall adjacent to the bottom, the first top radius adjacent to the first side wall, and the second top radius adjacent to the second side wall.

18. The method of claim 16, further comprising:

applying a cover layer to the golf club face before forming the groove and the second portion,

wherein:

the surface roughness of the cover layer is different than the surface roughness of a surface of the groove and the second portion.

19. The method of claim **16**, wherein:

rotating the groove forming tool comprises:

rotating the groove forming tool at an angle perpendicular to the golf club face.

20. The method of claim **16**, wherein:

the first top radius comprises a first thirty degree point; and the second top radius comprises a second thirty degree point.

rotating the groove forming tool further comprises:

rotating the groove forming tool such that the groove forming tool forms the groove in the golf club face such that a distance between the first thirty degree point and the second thirty degree point is equal to or less than 0.035 inches.

21. The method of claim **16**, further comprising:

smoothing the golf club face before forming the groove and the second portion.

* * * * *