



US 20130072321A1

(19) **United States**

(12) **Patent Application Publication**
Morales et al.

(10) **Pub. No.: US 2013/0072321 A1**

(43) **Pub. Date: Mar. 21, 2013**

(54) **GOLF CLUB FACE PLATES WITH INTERNAL CELL LATTICES AND RELATED METHODS**

Publication Classification

(75) Inventors: **Eric J. Morales**, Laveen, AZ (US); **Erik Henrikson**, Tempe, AZ (US)

(51) **Int. Cl.**
A63B 53/04 (2006.01)
B23P 17/04 (2006.01)
B23P 11/00 (2006.01)
B23K 31/02 (2006.01)
B23K 20/00 (2006.01)

(73) Assignee: **KARSTEN MANUFACTURING CORPORATION**, Phoenix, AZ (US)

(21) Appl. No.: **13/352,086**

(52) **U.S. Cl.**
USPC **473/342**; 228/159; 228/193; 29/428

(22) Filed: **Jan. 17, 2012**

(57) **ABSTRACT**

Related U.S. Application Data

(60) Provisional application No. 61/537,278, filed on Sep. 21, 2011.

Embodiments of golf club face plates with internal cell lattices are presented herein. Other examples and related methods are also disclosed herein.

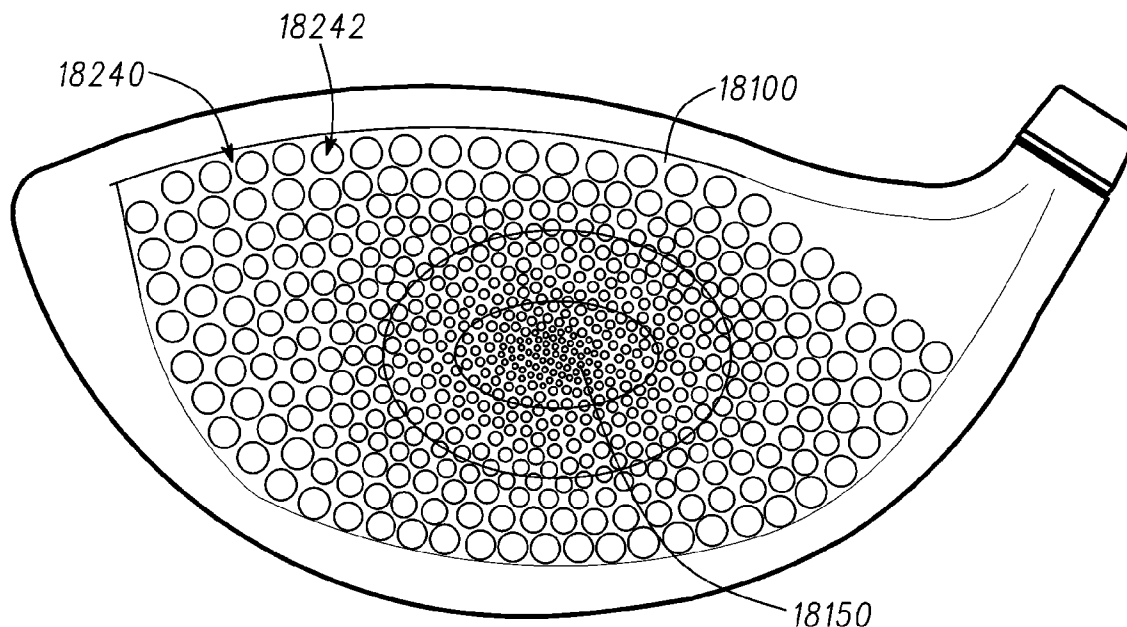

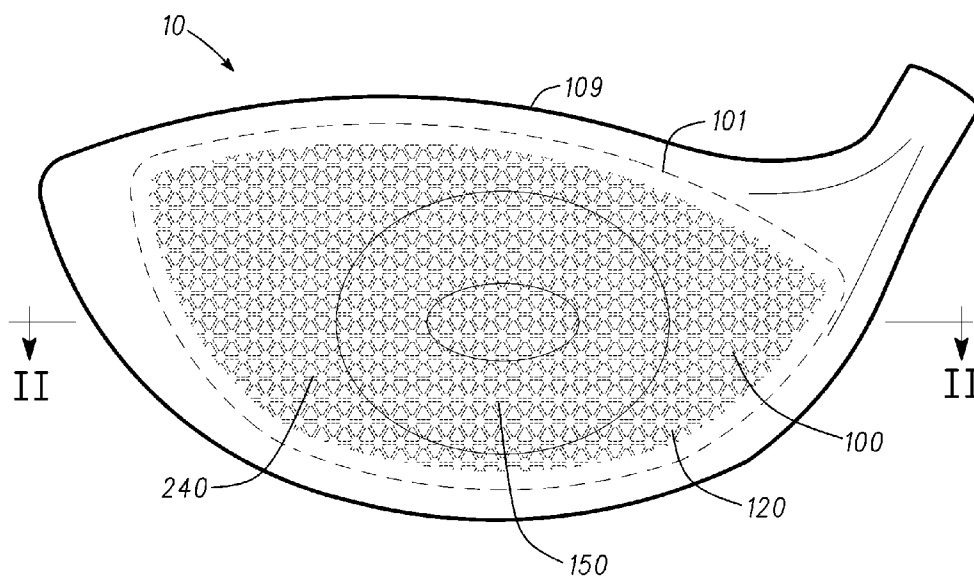

Fig. 1

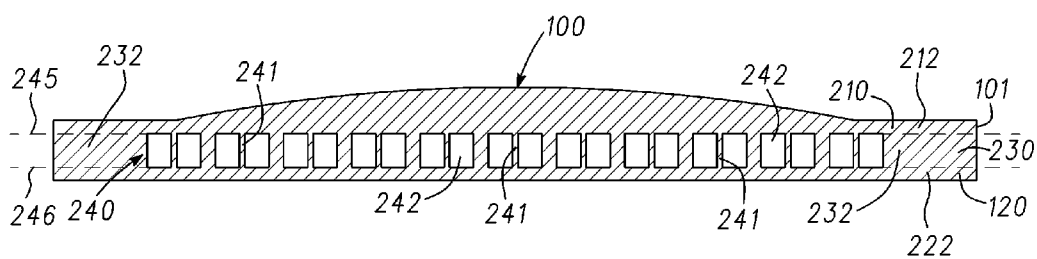

Fig. 2

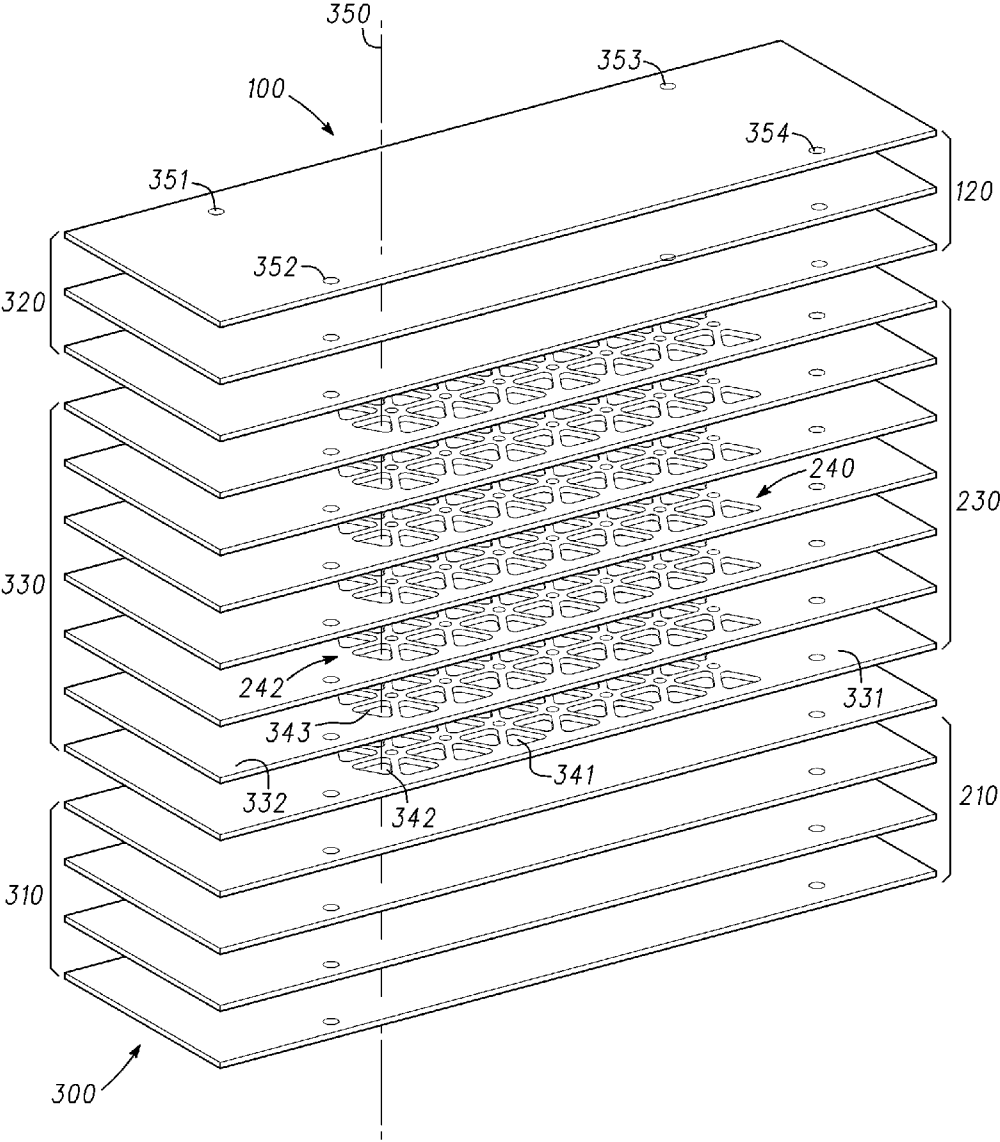

Fig. 3

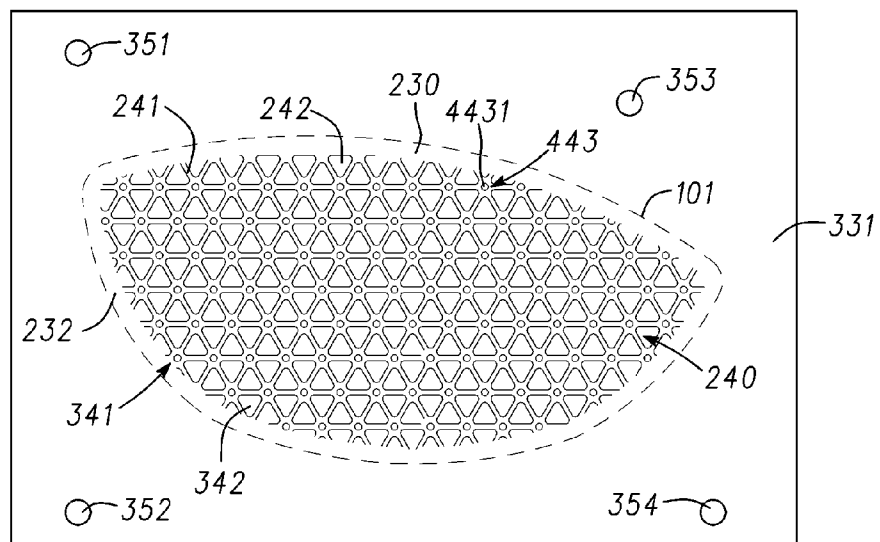

Fig. 4

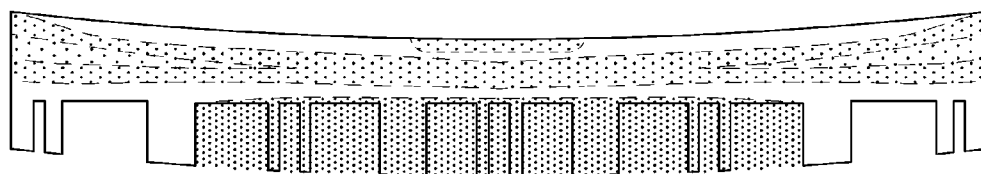

Fig. 5

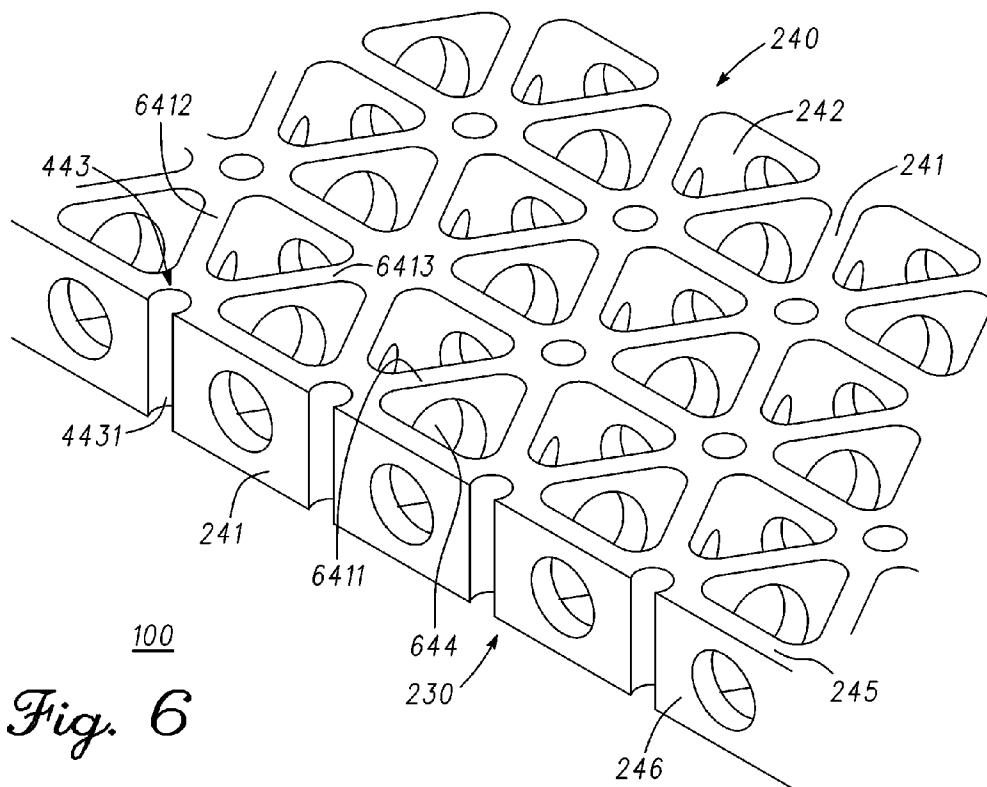

Fig. 6

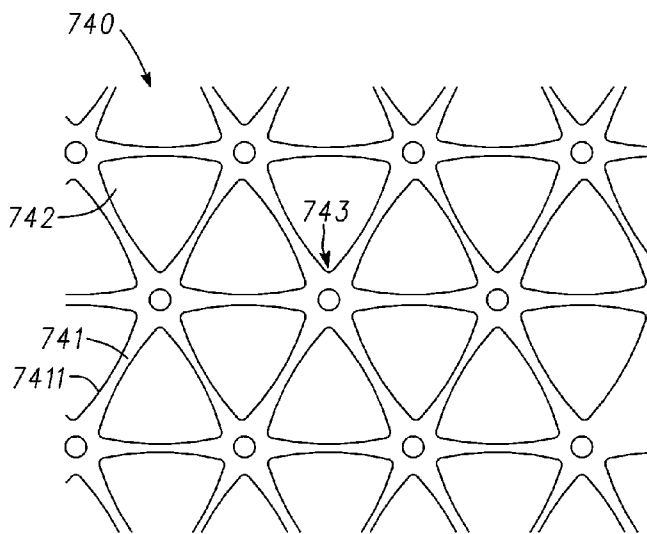
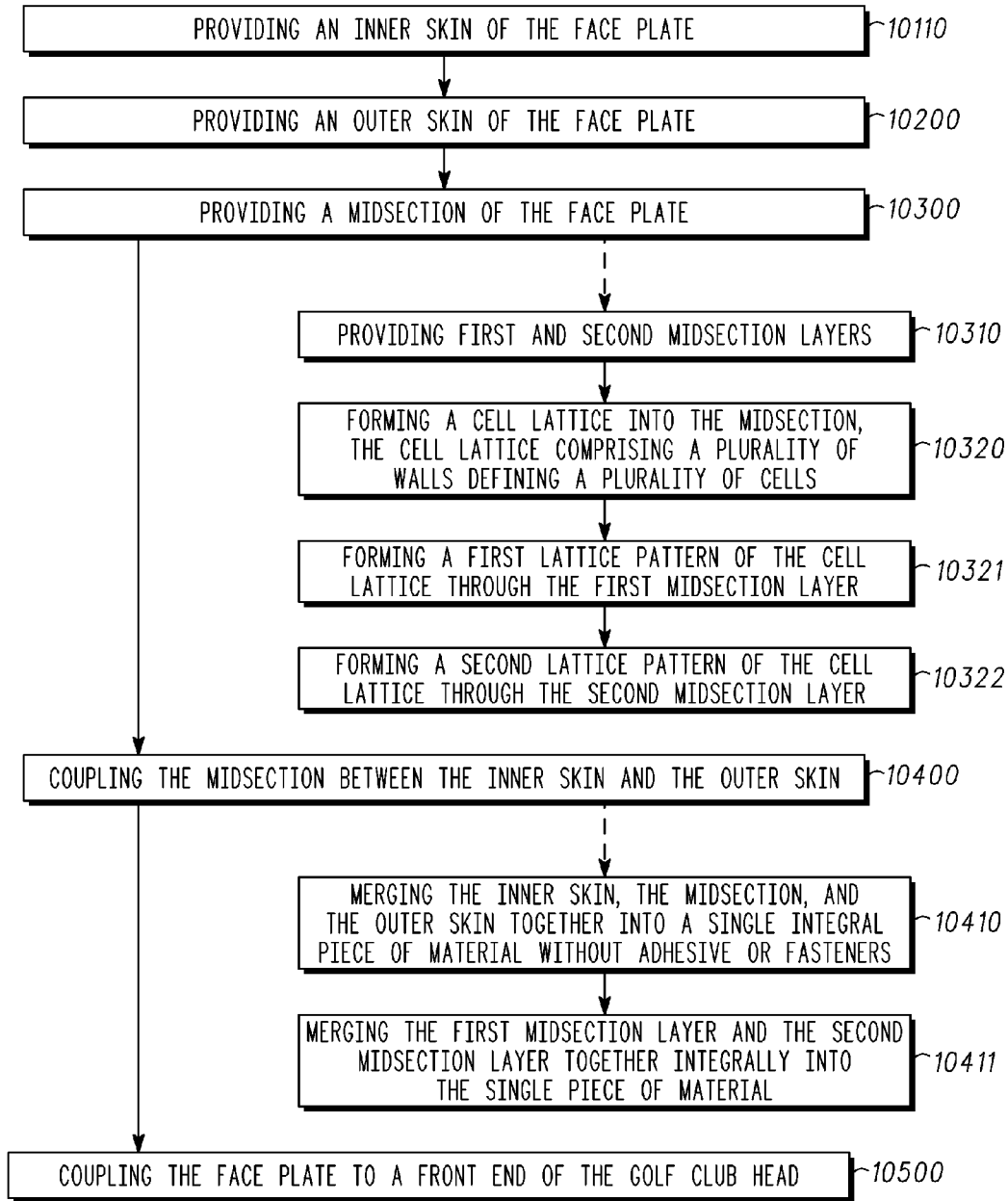
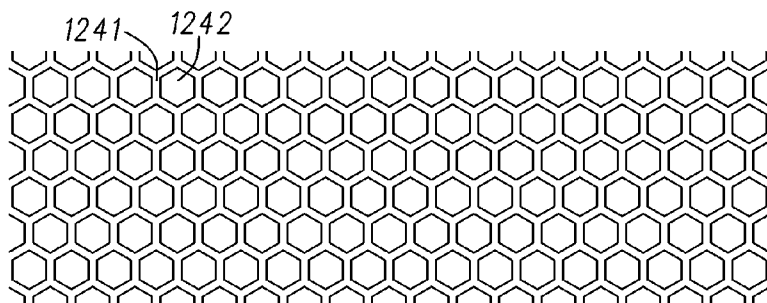

Fig. 7



1000

Fig. 10



1240

Fig. 12

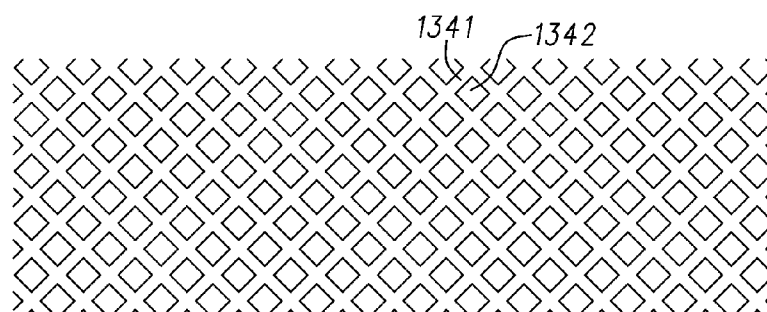

1340

Fig. 13

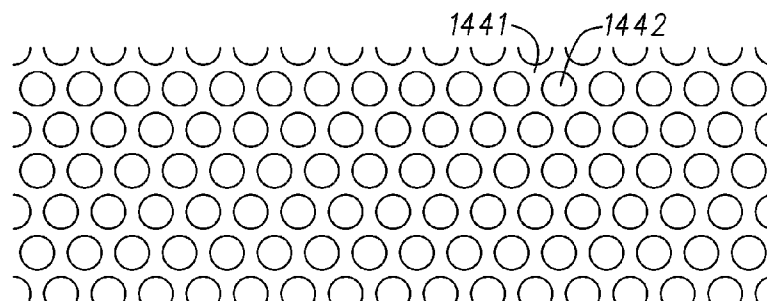

1440

Fig. 14

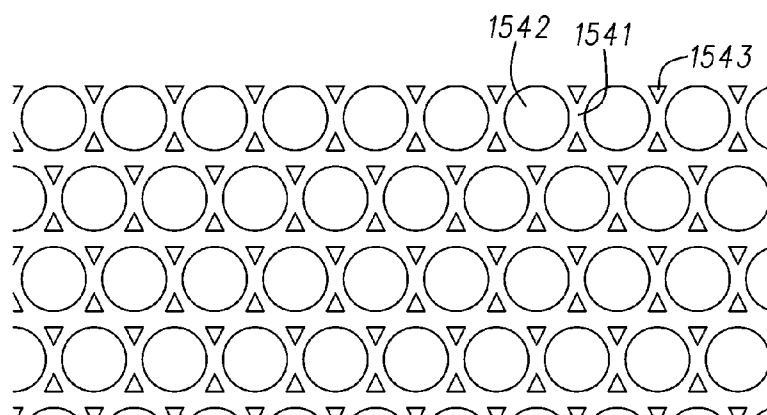

1540

Fig. 15

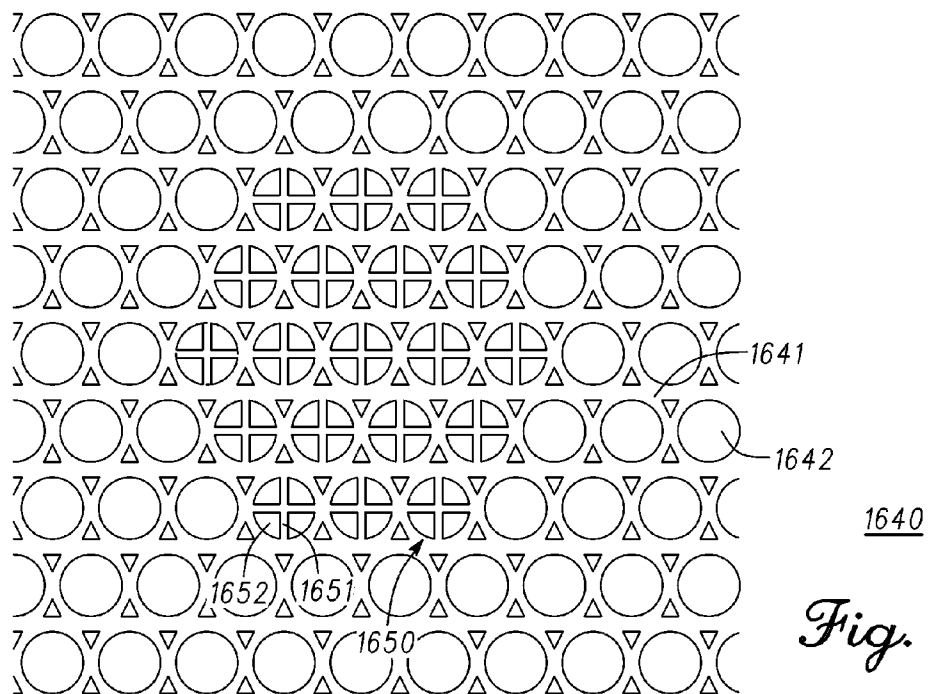

Fig. 16

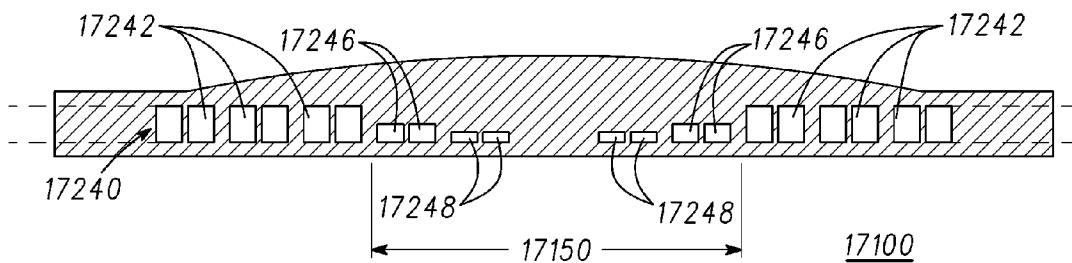

Fig. 17

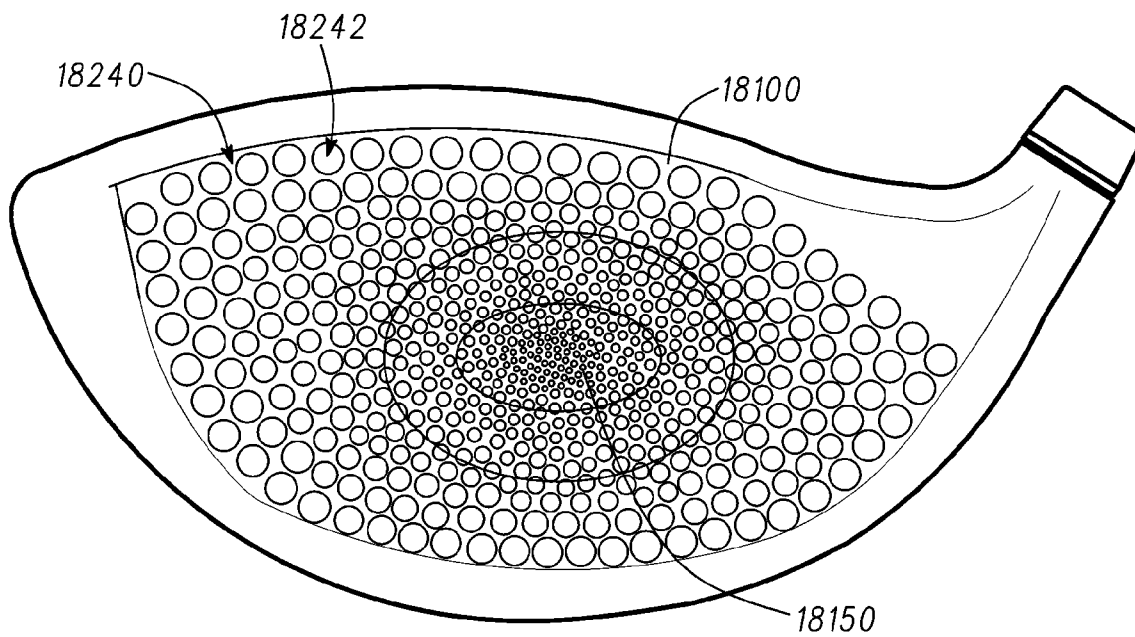

Fig. 18

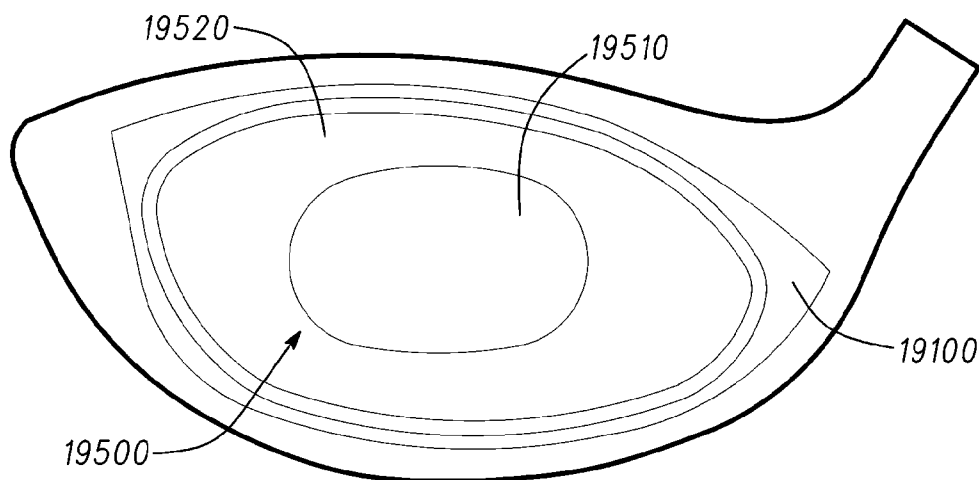

Fig. 19

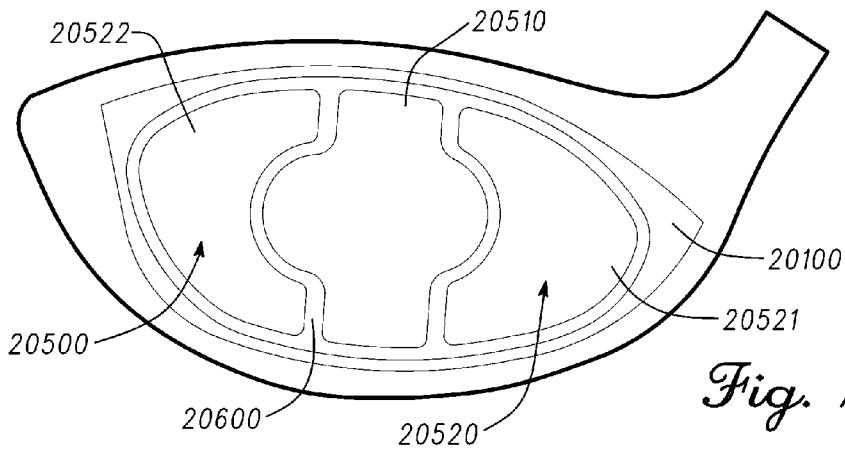

Fig. 20

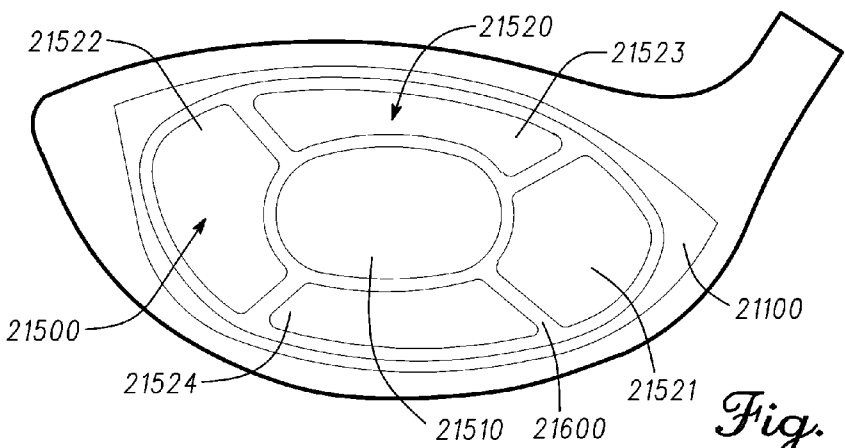

Fig. 21

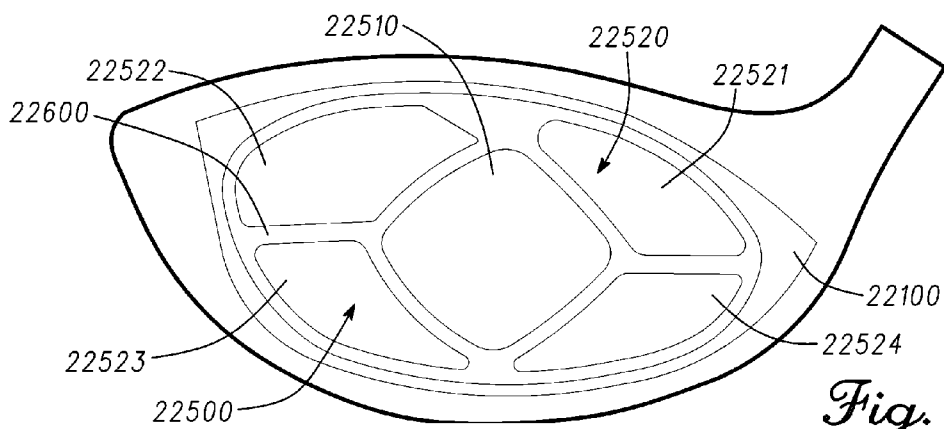

Fig. 22

GOLF CLUB FACE PLATES WITH INTERNAL CELL LATTICES AND RELATED METHODS

CROSS-REFERENCE TO RELATED APPLICATIONS

[0001] This is a non-provisional utility patent application claiming priority to U.S. Provisional Patent Application No. 61/537,278, filed on Sep. 21, 2011, and titled "Golf Club Face Plates With Internal Cell Lattices And Related Methods." The contents of the disclosure listed above are incorporated herein by reference.

TECHNICAL FIELD

[0002] The present disclosure relates generally to sports equipment, and relates, more particularly, to golf club face plates with internal cell lattices and related methods.

BACKGROUND

[0003] The development of golf club head technology has been characterized in part by the desire to enhance playability characteristics while managing weight and mass location considerations. The ability to alter or redistribute mass at or around locations of high stress and/or of limited thickness in a golf club head, however, has to be balanced with respect to structural resilience considerations. Considering the above, further developments in terms of weight redistribution will advance the playability characteristics of golf club heads.

BRIEF DESCRIPTION OF THE DRAWINGS

[0004] The present disclosure will be better understood from a reading of the following detailed description of examples of embodiments, taken in conjunction with the accompanying figures in the drawings.

[0005] FIG. 1 illustrates a front perspective view of a golf club head comprising a face plate coupled to a club head body.

[0006] FIG. 2 illustrates a cross-sectional view of the face plate of FIG. 1, cut along line II-II.

[0007] FIG. 3 illustrates a perspective view of portions of different layers comprising the face plate of FIG. 1 prior to being merged together.

[0008] FIG. 4 illustrates a front view of a midsection layer of the face plate of FIG. 1, comprising a lattice pattern and alignment elements.

[0009] FIG. 5 illustrates a finite element analysis graphic showing uneven stress distribution detrimentally concentrated in and around void portions of an exposed cell lattice in an embodiment of a face plate lacking an inner skin layer.

[0010] FIG. 6 illustrates a perspective view of a portion of the cell lattice of the face plate of FIG. 1.

[0011] FIG. 7 illustrates a front view of a portion of a cell lattice of a face plate.

[0012] FIG. 8 illustrates a side view of a portion of a cell lattice of a face plate.

[0013] FIG. 9 illustrates a side view of a portion of a cell lattice of a face plate.

[0014] FIG. 10 illustrates a flowchart for a method for providing a face plate for a golf club head.

[0015] FIG. 11 illustrates a portion of a cell lattice of a face plate.

[0016] FIG. 12 illustrates a portion of a cell lattice of a face plate.

[0017] FIG. 13 illustrates a portion of a cell lattice of a face plate.

[0018] FIG. 14 illustrates a portion of a cell lattice of a face plate.

[0019] FIG. 15 illustrates a portion of a cell lattice of a face plate.

[0020] FIG. 16 illustrates a portion of a cell lattice of a face plate.

[0021] FIG. 17 illustrates a cross-sectional view of a face plate having a cell lattice with cells that vary in height amongst each other.

[0022] FIG. 18 presents a front "x-ray" perspective view of a faceplate comprising a cell lattice variable cell dimensions.

[0023] FIG. 19 illustrates a front view of a faceplate subdivided into different cell lattice regions with one or more cell lattices therewithin.

[0024] FIG. 20 illustrates a front view of a faceplate subdivided into different cell lattice regions with one or more cell lattices therewithin.

[0025] FIG. 21 illustrates a front view of a faceplate subdivided into different cell lattice regions with one or more cell lattices therewithin.

[0026] FIG. 22 illustrates a front view of a faceplate subdivided into different cell lattice regions with one or more cell lattices therewithin.

[0027] For simplicity and clarity of illustration, the drawing figures illustrate the general manner of construction, and descriptions and details of well-known features and techniques may be omitted to avoid unnecessarily obscuring the present disclosure. Additionally, elements in the drawing figures are not necessarily drawn to scale. For example, the dimensions of some of the elements in the figures may be exaggerated relative to other elements to help improve understanding of embodiments of the present disclosure. The same reference numerals in different figures denote the same elements.

[0028] The terms "first," "second," "third," "fourth," and the like in the description and in the claims, if any, are used for distinguishing between similar elements and not necessarily for describing a particular sequential or chronological order. It is to be understood that the terms so used are interchangeable under appropriate circumstances such that the embodiments described herein are, for example, capable of operation in sequences other than those illustrated or otherwise described herein. Furthermore, the terms "include," and "have," and any variations thereof, are intended to cover a non-exclusive inclusion, such that a process, method, system, article, device, or apparatus that comprises a list of elements is not necessarily limited to those elements, but may include other elements not expressly listed or inherent to such process, method, system, article, device, or apparatus.

[0029] The terms "left," "right," "front," "back," "top," "bottom," "over," "under," and the like in the description and in the claims, if any, are used for descriptive purposes and not necessarily for describing permanent relative positions. It is to be understood that the terms so used are interchangeable under appropriate circumstances such that the embodiments of the apparatus, methods, and/or articles of manufacture described herein are, for example, capable of operation in other orientations than those illustrated or otherwise described herein.

[0030] The terms "couple," "coupled," "couples," "coupling," and the like should be broadly understood and refer to connecting two or more elements or signals, electrically, mechanically or otherwise. Two or more electrical elements may be electrically coupled, but not mechanically or other-

wise coupled; two or more mechanical elements may be mechanically coupled, but not electrically or otherwise coupled; two or more electrical elements may be mechanically coupled, but not electrically or otherwise coupled. Coupling (whether mechanical, electrical, or otherwise) may be for any length of time, e.g., permanent or semi-permanent or only for an instant.

[0031] “Mechanical coupling” and the like should be broadly understood and include mechanical coupling of all types. The absence of the word “removably,” “removable,” and the like near the word “coupled,” and the like does not mean that the coupling, etc. in question is or is not removable.

[0032] As defined herein, two or more elements are “integral” if they are comprised of the same piece of material. As defined herein, two or more elements are “non-integral” if each is comprised of a different piece of material.

DETAILED DESCRIPTION

[0033] In one embodiment, a method for providing a face plate for a golf club head can comprise providing an inner skin of the face plate, providing an outer skin of the face plate, providing a midsection of the face plate, and bounding the midsection between the inner skin and the outer skin. Providing the midsection can comprise providing a plurality of midsection layers comprising a first midsection layer and a second midsection layer, forming a first lattice pattern through the first midsection layer, and forming a second lattice pattern through the second midsection layer. Providing the inner skin, the outer skin, and the midsection can comprise providing each of the midsection, the inner skin, or the outer skin as separate distinct pieces. Bounding the midsection can comprise diffusion bonding the inner skin, the midsection, and the outer skin together, including the first and second midsection layers, into a single integral piece of material that is substantially seamless between the inner skin and the midsection and between the midsection and the outer skin. After the diffusion bonding, a midsection central area of the midsection can comprise a cell lattice, the cell lattice can comprise a plurality of walls defining a plurality of cells in a hexagonal pattern, the plurality of walls and the plurality of cells of the cell lattice can be defined at least in part by the first and second lattice patterns, the cell lattice can be fully bounded between the inner and outer skins of the face plate, and a midsection perimeter area of the midsection can bound the midsection central area and can be devoid of the cell lattice. Forming the first lattice pattern through the first midsection layer can comprise forming a first cutout through the first midsection layer, the first cutout configured to define a first volume portion of a first cell of the cell lattice. Forming the second lattice pattern through the second midsection layer can comprise forming a second cutout through the second midsection layer, the second cutout configured to define a second volume portion of the first cell. Bounding the midsection can comprise aligning the second midsection layer over the first midsection layer such that the first and second cutouts are centered about a first cell axis of the first cell.

[0034] In one embodiment, a method for providing a face plate for a golf club head can comprise providing an inner skin of the face plate, providing an outer skin of the face plate, providing a midsection of the face plate, and coupling the midsection between the inner skin and the outer skin such that an inner midsection end of the midsection is coupled to the inner skin of the face plate, and such that an outer midsection end of the midsection is coupled to the outer skin of the face

plate. Providing the midsection can comprise providing a cell lattice in the midsection, the cell lattice comprising a plurality of walls defining a plurality of cells.

[0035] In one embodiment, a face plate for a golf club head can comprise an inner skin, an outer skin, and a midsection. The midsection can comprise an inner midsection end coupled to the inner skin, an outer midsection end coupled to the outer skin, and a cell lattice comprising a plurality of walls defining a plurality of cells between the inner midsection end and the outer midsection end.

[0036] Other examples and embodiments are further disclosed herein. Such examples and embodiments may be found in the figures, in the claims, and/or in the present description.

[0037] Turning to the drawings, FIG. 1 illustrates a front perspective view of golf club head 10 comprising face plate 100 coupled to club head body 109. FIG. 2 illustrates a cross-sectional view of face plate 100 cut along line II-II of FIG. 1. As can be seen in FIG. 2, face plate 100 comprises inner skin 210, outer skin 120, and midsection 230 between inner skin 210 and outer skin 120, where midsection 230 comprises cell lattice 240 having walls 241 defining cells 242. In the present example, cell lattice 240 extends from inner midsection end 245 (where cell lattice 240 is coupled to inner skin 210), to outer midsection end 246 (where cell lattice 240 is coupled to inner skin 210). Cell lattice 240 is thus fully encapsulated within faceplate 100 in the present example, between inner skin 120 and outer skin 210, and by perimeter midsection area 232. Although inner midsection end 245 and outer midsection end 246 are represented along dotted lines in FIG. 2, in the present embodiment the interface between midsection 230 and inner skin 210 or outer skin 120 may be seamless or imperceptible visually and/or structurally.

[0038] The different portions of faceplate 100 can comprise different thicknesses. In the present example, the thickness of outer skin 120 is approximately 0.03 inches (approximately 0.08 millimeters (mm)); the thickness of midsection 230 is approximately 0.07 inches (approximately 1.78 mm); and the thickness of inner skin varies, being approximately 0.05 inches (approximately 0.13 mm) towards the center, and approximately 0.03 inches (approximately 0.08 mm) towards the perimeter. The thickness of inner skin 210 is greater than the thickness of outer skin 120 in the present example, where inner skin 210 faces away from the impact surface of faceplate 100, to better distribute impact stresses throughout the faceplate. In some examples, the thickness of inner skin 210 and outer skin 120 can be substantially similar to each other, and/or may not vary.

[0039] In the present example, face plate 100 is shown with inner skin 210, outer skin 120, and midsection 230 merged together into a single integral piece of material. In some examples, inner skin 210, outer skin 120, and/or midsection 230 may be merged together without using adhesives or fasteners, such as via a high-pressure and/or high-heat process. In the same or other examples, such process may comprise a diffusion bonding process. The ability to combine midsection 230 between inner skin 210 and outer skin 120 and into a single integral piece of material can provide many benefits, such as a reduction in the weight of face plate 100 via cell lattice 240. In some examples, encapsulating cell lattice 240 within face plate 100 can permit weight savings of approximately 8% to approximately 25%. Such results can be achieved without compromising the strength or durability of face plate 100, and without introducing detrimental bending,

elastic and/or flexing susceptibilities that would result from uneven stress distribution if, for example, face plate 100 were made with cell lattice 240 exposed and/or without one of inner skin 210 or outer skin 120. As an example, and skipping ahead in the figures, FIG. 5 illustrates a cross-sectional view of a finite element analysis graphic showing uneven stress distribution detrimentally concentrated, as denoted by the heavily-dotted center region, in and around the void portions of an exposed cell lattice in an embodiment comprising only a single skin coupled to the cell lattice.

[0040] Backtracking to FIG. 3, a perspective view is illustrated of portions of different layers 300 comprising face plate 100 prior to being merged together, including midsection layers 330. In the present example, midsection 230 comprises midsection layers 330 merged together into the single integral piece of material of face plate 100. In the same or other examples, the plurality of midsection layers 330 can be merged together via the high-pressure and high-heat process described above. As can be seen in FIG. 3, inner skin 210 and outer skin 120 can also be formed out of several layers, such as outer skin layers 320 and inner skin layers 310, which may be merged together into the single integral piece of material of face plate 100. Although in the present embodiment inner skin 210 comprises more inner skin layers 310 than outer skin 120 comprises outer skin layers 320, there can be other embodiments where such relationship is inverse, or where both skins comprise the same number of layers. There may be other embodiments, however, where one or more of inner skin 210, outer skin 120, and/or midsection 230 may originally comprise a single layer, rather than a plurality of layers coupled together.

[0041] FIG. 3 shows portions of layers 300 as sheets of metallic material, and illustrate midsection layers 330 with representative cutouts configured to form cell lattice 240 when merged together. FIG. 4 illustrates a front view of midsection layer 331 of midsection 230, comprising lattice pattern 341 and alignment elements 351-354. Lattice pattern 341 comprises a plurality of cutouts, such as cutout 342, that define a layer portion of walls 241 and a layer portion of the volume of cells 242 of cell lattice 240. In some examples, cell lattice 240 may be formed by one or more processes, such as by machining and/or by chemically etching the cutouts of the different lattice patterns of midsection layers 330 prior to merging layers 300 (FIG. 3) together. In examples involving the machining of cell lattice 240 or one or more of its elements, such machining can be carried out via one or more techniques, such as through computer numerical control (CNC) machining, waterjet cutting, and/or electrical discharge machining.

[0042] Although in the present example the cutouts of lattice pattern 341 are all similar to each other, there can be other examples where the cutouts can have different geometries, different dimensions, such as different radiuses, different perimeter lengths, different areas, and/or different volumes. The same or other examples may comprise other patterns, such as a pattern where a density in the number of cells 242 decreases towards target strike region 150 of face plate 100, and/or a pattern where a size or dimension of cells 242 decreases towards target strike region 150 of face plate 100.

[0043] Referring to FIG. 4, alignment elements 351-354 of midsection layer 331 is representative of corresponding alignment elements in other ones of layers 300 (FIG. 3). Alignment elements 351-354 are configured so that respective alignment elements 351-354 of different ones of layers

300 will align with each other only in a single orientation when layers 300 are stacked as shown in FIG. 3. Thus, when alignment elements 351-354 are aligned with each other throughout layers 300, walls 241 and the different lattice patterns of midsection layers 330, such as lattice pattern 341, will also be aligned to yield cell lattice 240 (FIGS. 2-3) once layers 300 are merged together. In the present example, by aligning alignment elements 351-354 throughout layers 300, the cutouts of the different layers 300 will also be aligned relative to each other. For instance, as can be seen in FIG. 3, cutouts 342 and 343 are located in different ones of midsection layers 330, but are both centered about cell axis 350 when alignment elements 351-354 are aligned throughout layers 300. Once layers 300 are merged together, the different cutouts of midsection layers 330 that are centered about cell axis 350 define a single cell of cells 242 of cell lattice 240. There can be other examples, however, where cutouts of different ones of midsection layers 330 may be offset from each other, rather than aligned or centered about a cell axis.

[0044] In the present example, each of layers 300 of face plate 100 comprises the same type of material. As an example, midsection 230, inner skin 210, and outer skin 120, and respective midsection layers 330, inner skin layers 310, and outer skin layers 320, comprise a metallic material such as a metallic alloy. In the present example, individual ones of layers 300, such as layer 331, can comprise a thickness of approximately 0.01 inch or approximately 0.25 mm. In the same or other embodiments, one or more of such layers 300 can comprise a thickness ranging from between approximately 0.25 mm to approximately 2.54 mm.

[0045] In the present embodiment, the metallic material for layers 300 of face plate 100 can comprise a titanium alloy comprising at least approximately 8% aluminum (by volume). In the same or other examples, the metallic alloy can comprise a titanium 8-1-1 alloy having approximately 8% aluminum, 1% vanadium and 1% chromium. Other materials may be used depending on their strength, considering their brittleness/elasticity as a beta-type crystal structure. For example, a titanium 6-4 alloy having approximately 6% aluminum and 4% vanadium, may be used in some embodiments, but can be from 5% to 12% less elastic than titanium 8-1-1 and may thus require further reinforcement or thickness for face plate 100 to properly withstand golf impact stresses. In contrast, other materials such as commercially pure titanium, may not be suitable to properly withstand the stresses to which face plate 100 is subjected.

[0046] There can be examples where the metallic alloy of layers 300 may comprise an alpha-type crystal structure prior to being merged together, and a stronger beta-type crystal structure after being merged together, such as via the high-heat and high pressure process described above. As an example, the alpha-type crystal structure may comprise a hexagonal crystal phase, and/or the beta-type crystal structure may comprise a body-centered cubic crystal phase. The transformation to beta-type crystal structure can permit the crystal structure of adjacent layers of layers 300 to be intermeshed together at a molecular level once the merging process is completed to yield the single integral piece of material for face plate 100.

[0047] As can be seen in FIGS. 3-4, the sheets of metallic material containing layers 300 are larger than face plate 100 in the present example. In the same or other examples, face plate 100 can be separated from the other portions of the sheets of metallic material once layers 300 have been merged

into the single integral piece of material, by water jetting or by otherwise cutting along a cut perimeter defining face plate edge **101** of face plate **100**, such as the cut perimeter depicted in dotted lines in FIG. 4.

[0048] In the present example, face plate **100** comprises cell lattice **240** in a central area of midsection **230**, as can be seen from the exemplary midsection layer **331** shown in FIG. 4. Midsection **230** also comprises perimeter midsection area **232** bounding cell lattice **240** and devoid of cells **242**. Cell lattice **240** is thus separated from face plate edge **101** by perimeter midsection area **232**. In some examples, separating cell lattice **240** from face plate edge **101** can permit cell lattice **240** to be distanced away from an interface or weld zone with club head body **109** when face plate **100** is coupled to a front end of golf club head **10**. In the same or other examples, such distancing of cell lattice **240** from face plate edge **101** and the interface with club head body **109** can be beneficial for permitting a better weld or bond between face plate **100** and club head body **109**. There can be other examples, however, where cell lattice **240** may extend within midsection **230** to face plate edge **101** or adjacent thereto.

[0049] Cell lattice **240** comprises a hexagonal isogrid pattern with six subcells per hexagon in the present example, as can be seen in FIG. 4, providing the strength-to-weight performance and versatility of a reinforced honeycomb structure. In the present embodiment, each of the six subcells comprise the same triangular shape. In the same or other examples, the depth of the walls of a cell or subcell (between inner skin **210** and outer skin **120**) can be approximately 0.07 inches (approximately 1.78 mm), the length of the walls of the cell or subcell can be approximately 0.06 inches (approximately 1.53 mm), and/or the thickness of the walls of the cell or subcell can be approximately 0.01 inches (approximately 0.25 mm). In the same or other examples, the depth of the walls of a cell or subcell can be approximately 1.27 mm to approximately 3.05 mm, the length of the walls of the cell or subcell can be approximately 1 mm to approximately 3.05 mm, and/or the thickness of the walls of the cell or subcell can be approximately 0.20 mm to approximately 0.76 mm. Other examples of cell lattices, however, may comprise different shapes and/or dimensions.

[0050] Continuing with the figures, FIG. 6 illustrates a perspective view of a portion of cell lattice **240** of face plate **100**, with inner skin **210**, outer skin **120**, and perimeter midsection area **232** removed for clarity. Cell lattice **240** comprises a plurality of cell junctions, such as cell junction **443**, where two or more of walls **241** couple together. In the present example, the cell junctions provide an arcuate transition between the walls of a cell. For example, walls **6412** and **6413** meet at cell junction **443**, and the interface between them at cell junction **443** is arcuate rather than pointed or sharp. In the present example, such arcuate interface comprises a radius of approximately 0.05 inch (approximately 0.13 mm), but there can be other examples where the arcuate interface can comprise a radius of approximately 0.025 mm to approximately 0.40 mm. Such arcuate features can be valuable, for example, to avoid sharp edges or corners that could concentrate stresses that could cause material fatigue and/or cracking within the cell lattice.

[0051] Also in the present example, one or more of the cell junctions can comprise respective junction channels, such as junction channel **4431** extending into cell junction **443** from inner midsection end **245** to outer midsection end **246**. Junction channel **4431** comprises a largest dimension or diameter

of approximately 0.015 inches (approximately 0.38 mm) in the present example, but there can be examples where similar junction channels can comprise a diameter and/or largest dimension of approximately 0.2 mm to approximately 0.66 mm.

[0052] In addition, cell lattice **240** also comprises one or more transverse passageways in the present example, such as transverse passageway **644** between at least two adjacent cells of cells **242**. Transverse passageway **644** comprises a largest dimension or diameter of approximately 0.05 inches (approximately 1.27 mm) in the present example, but there can be examples where similar transverse passageways can comprise a diameter and/or largest dimension of approximately 0.5 mm to approximately 1.27 mm.

[0053] The addition of features such as junction channel **4431** and transverse passageway **644** can permit additional reduction in weight without compromising the strength or integrity of face plate **100**. Also, the geometry and/or shape of junction channel **4431** and/or passageway **644** can be changed to be the same geometry and/or shape as cells **242** or another geometry and/or shape. Additionally, different ones of junction channel **4431** and/or passageway **644** can have different geometries and/or shapes.

[0054] FIG. 7 illustrates a portion of cell lattice **740**. In some examples, cell lattice **740** can be similar to cell lattice **240** (FIGS. 1-4, 6), and may be located between skins such as inner skin **210** and outer skin **120**, as described above with respect to face plate **100** in FIGS. 1-3. Cell lattice **740** comprises walls **741** and cells **742**, respectively similar to walls **241** and walls **242** (FIGS. 1-4, 6), but where walls **741** comprise varying wall dimensions. As an example, the wall thickness dimension of wall **7411** varies along its length, the wall thickness being thinner towards the center of its length and thicker towards the ends of its length. In the present example, such variation in wall thickness dimension also affects the dimensions of cells **742**, where the walls of the isogrid triangular cells comprise arcuate legs, and where the hexagonal shape defined by cells bounding a cell junction, such as cell junction **743**, is now arcuate and/or circular. In other examples, the wall thickness dimensions could vary otherwise, such as by being thicker towards the center of their respective lengths, and by being thinner towards the respective length ends thereof.

[0055] FIG. 8 illustrates a portion of cell lattice **840**. In some examples, cell lattice **840** can be similar to cell lattice **240** (FIGS. 1-4, 6) and/or cell lattice **740** (FIG. 7). Cell lattice **840** is located between skins **810** and **820**, which can be similar to inner skin **210** and/or outer skin **120**, respectively, as described above with respect to face plate **100** (FIGS. 1-4, 6). Cell lattice **840** comprises walls **841** and cells **842**, respectively similar to walls **241** and cells **242** (FIGS. 1-4, 6), and/or to walls **741** and cells **742** (FIG. 7). Walls **841** comprise varying wall dimensions in the present embodiment. As an example, the wall thickness dimension of wall **8411** varies along its height, the wall thickness being thinner towards the center of its height and thicker towards the ends of its height. In the present example, such variation in wall thickness dimension also affects the dimensions of cells **842**, which can thus comprise a greater volume and arcuate dimensions. In other examples, the wall thickness dimensions could vary otherwise, such as by being thicker towards the center of their respective heights, and by being thinner towards the respective height ends thereof.

[0056] Skipping ahead in the figures, FIG. 11 illustrates a portion of cell lattice 1140 with varying wall dimensions. In some examples, cell lattice 1140 can be similar to cell lattice 240 (FIGS. 1-4, 6), cell lattice 740 (FIG. 7), and/or cell lattice 840 (FIG. 8). Cell lattice 1140 is located between skins 1110 and 1120, which can be similar to inner skin 210 and/or outer skin 120, respectively, as described above with respect to face plate 100 (FIGS. 1-4, 6). Cell lattice 1140 comprises walls 1141 and cells 1142, respectively similar to walls 241 and cells 242 (FIGS. 1-4, 6), to walls 741 and cells 742 (FIG. 7), and/or to walls 841 and cells 842 (FIG. 8). Walls 1141 also comprise varying wall dimensions in the present embodiment, tapering in thickness between skin 1110 and skin 1120. As an example, wall 11411 is thicker towards skin 1120, and decreases to a thinner thickness towards skin 1110. In the same or other examples, skin 1120 is configured to comprise the external surface of the faceplate, such that the thicker portion of walls 1141 face towards the impact surface of the faceplate. There may be other embodiments, however, where the thinner portion of walls 1141 can face towards the impact surface of the faceplate.

[0057] Backtracking through the figures, FIG. 9 illustrates a portion of cell lattice 940. In some examples, cell lattice 940 can be similar to cell lattice 240 (FIGS. 1-4, 6), cell lattice 740 (FIG. 7), cell lattice 840 (FIG. 8), and/or cell lattice 1140 (FIG. 11). Cell lattice 940 is located between skins 910 and 920, which can be similar to inner skin 210 and/or outer skin 120, as described above with respect to face plate 100 (FIGS. 1-4, 6). Cell lattice 940 comprises cells 942, which can be similar to cells 242 (FIGS. 1-4, 6), to cells 742 (FIG. 7), to cells 842 (FIG. 8), and/or to cells 1142 (FIG. 11). Cells 942 are offset from each other in the present example. For instance, cell 9421 is offset from cell 9422, which is offset from cell 9423. In addition, in the present example, midsection layers 931-933 define midsection 930 comprising cell lattice 940. Midsection layers 931-933 can be similar to, and may be merged together as described above, with respect to midsection layers 330 of face plate 100 (FIG. 3). Each of midsection layers 931-933 can comprise multiple layers before being merged together to form midsection 930. In the present example, cell 9422 is at least partially capped or defined by solid portions of midsection layers 931, 932, and 933 and cell 9421 is at least partially capped or defined by solid portions of midsection layers 931 and 932 and skin 920.

[0058] There can be other examples, however, that can comprise cell lattices with other types of geometrical shapes, dimensions, or combinations thereof. For instance skipping ahead to FIG. 12, cell lattice 1240 is presented with walls 1241 defining hexagonal cells 1242. FIG. 13 presents cell lattice 1340 with walls 1341 defining diamond or square cells 1342. FIG. 14 presents cell lattice 1440 with walls 1441 defining round or circular cells 1442. Other shapes can also be implemented in the same or other cell lattice examples, such as pentagonal cells, octagonal cells, triangular cells, and/or combinations thereof, among others. For instance, FIG. 15 presents cell lattice 1540 with walls 1541 defining circular cells 1542 interspersed with triangular cells 1543.

[0059] There also can be examples where individual cells of a cell lattice can comprise subcells therewithin. For example, cells 242 (FIGS. 1-4, 6) can be considered in some examples as defining subcells of larger hexagonal cells of cell lattice 240. As another example, FIG. 16 presents cell lattice 1640 with walls 1641 defining cells 1642, where cell subset 1650 of cells 1642 comprise subcells 1652 defined by sub-

walls 1651 within individual cells of cell subset 1650. Cell subsets such as cell subset 1650 may be located at specific locations to reinforce against stresses expected thereat. In some examples, such cell subsets may be located at or by a target strike region of a faceplate, such as target strike region 150 of face plate 100 (FIG. 1). Other combinations of cells, subcells, shapes, and/or dimensions for a cell lattice may be formed by combining different cells, subcells, shapes, and/or dimensions disclosed herein or similar thereto.

[0060] Although cell lattices 1240 (FIG. 12), 1340 (FIG. 13), 1440 (FIG. 14), 1540 (FIG. 15), 1640 (FIG. 16), can differ in some aspects, they can be otherwise similar to one or more of cell lattices 240 (FIGS. 1-4, 6), cell lattice 740 (FIG. 7), cell lattice 840 (FIG. 8), and/or cell lattice 1140 (FIG. 11).

[0061] In some examples, the height of the cells of a cell lattice may vary from cell to cell. As an example, FIG. 17 presents a cross-sectional view of face plate 17100 with cell lattice 17240 similar to cell lattice 240 (FIGS. 1-4, 6). Cell lattice 17240, however, comprises cells that vary in height amongst each other. In the present example, the height of cells 17242 is greater than the height of cells 17246, and the height of cells 17246 is greater than the height of cells 17248. The cells of cell lattice 17240 are positioned in the present example such as to decrease in height towards a center of target strike region 17150, where greater stresses can be expected. In addition, the centermost portion of target strike region 17150 is devoid of any cell of cell lattice 17240 in the present example for further reinforcement. Other examples, however, may comprise cell lattices with cells whose heights vary in a different pattern.

[0062] FIG. 18 presents a front "x-ray" perspective view of a faceplate 18100 of a golf club head. Faceplate 18100 comprises cell lattice 18240 with variable cell dimensions. In the present example, cell lattice 18240 comprises a grid of cells 18242 that decrease in size towards a center of target strike region 18150. In the same or other examples, the walls between cells 18242 of cell lattice 18240 can increase in thickness towards the center of target strike region 18150. In other examples, the size of cells 18242, and/or the thickness of the walls therebetween, can increase or decrease in size towards another region of faceplate 18100, such as towards the crown region, the sole region, the heel region, and/or the toe region.

[0063] In the same or other examples, the size of cells 18242 can decrease or increase as a function of distance from the center of target strike region 18150. In other examples, however, the size and/or concentration of cells 18242 can change relative to another feature of the faceplate, such as by increasing or decreasing from top edge to bottom edge or the face plate, and/or such as by increasing or decreasing from heel end to toe end of the face plate. In some embodiments, cells 18242 can decrease in size or dimension between approximately 1% to approximately 10% from cell to cell as the distance to the center of target strike region 18150 shortens. In the same or other embodiments, a distance between cells 18242 can increase between approximately 1% to approximately 10% from cell to cell as the distance to the center of target strike region 18150 shortens. There can also be example where the change in size or concentration of cells 18242, relative to the center of target strike region 18150, can change in a non-linear and/or a step function fashion.

[0064] Although cells 18242 of cell lattice 18240 are illustrated in FIG. 18 as circular cells, cells 18242 can be representative of other shapes, sizes, or dimensions that can be

used to implement the varying cell size features described above. For instance, the cells of cell lattice **18240** could instead comprise other geometrical shapes such as triangles, hexagons, diamonds, octagons, pentagons, isogrids, and/or some combination thereof in some implementations while still varying in size or concentration across at least a portion of face plate **18100**.

[0065] FIG. 19 illustrates a front view of faceplate **19100** of a golf club head, where faceplate **19100** is subdivided into different cell lattice regions **19500** with one or more cell lattices therewithin. In the present example, cell lattice regions **19500** comprise center lattice region **19510** and periphery lattice region **19520**, where center lattice region **19510** is located at a center region of face plate **19100**, bounded by periphery lattice region **19520** around its perimeter. Center lattice region **19510** can be stiffer than periphery lattice region **19520**, which is more elastic in the present example, where the elasticity of cell lattice regions **19500** can be fine tuned by implementing appropriate cell patterns, features, and/or dimensions to achieve a desired elastic modulus range. In some examples, having center lattice region **19510** stiffer relative to periphery lattice region **19520** can allow more forgiveness for golf shots not hit at the target strike region of the face plate. In the same or other examples, a characteristic time (CT) of a golf club can also be adjusted or controlled by adjusting the flexibility or elasticity of different portions of the face plate such as cell lattice regions **19500**. There can be other examples, however, where the center lattice region **19510** need not be stiffer than periphery lattice region **19520**, and/or where center lattice region **19510** and periphery lattice region **19520** can comprise a substantially similar stiffness or modulus of elasticity.

[0066] In some examples, center lattice region **19510** may be similar to or correspond to target strike region **150** of face plate **100** (FIG. 1), or to other target strike regions of other face plates described herein. In the present example, cell lattice regions **19500** can comprise or be similar to one or more of the cell lattices described herein, but can differ from each other with respect to at least one feature. As an example, center lattice region **19510** can comprise a cell lattice similar to isogrid cell lattice **240** (FIGS. 1-4, 6), while periphery lattice region **19520** can comprise a cell lattice similar to hexagonal cell lattice **1240** (FIG. 12). As another example, center lattice region **19510** can comprise a cell lattice similar to circular cell lattice **1440** (FIG. 14), while periphery lattice region **19520** can comprise a cell lattice similar to multi-shaped cell lattice **1540** (FIG. 15). As yet another example, some cells of cell lattice regions **19500** can comprise subcells and/or subwalls. For instance, cells of center lattice region **19510** can comprise subcells and subwalls similar to cell subset **1650** (FIG. 16), while cells of periphery lattice region **19520** need not comprise subcells or subwalls. In the same or other examples, cell lattice regions **19500** can comprise cells of different heights. For instance, center lattice region **19510** can comprise cells of a reduced height, such as the cells of target strike region **17150** in FIG. 17, while periphery lattice region **19520** can comprise cells of greater height than those of periphery lattice region **19520**. In the same or other examples, center lattice region **19510** may be partially or totally devoid of cells, while surrounded by the cells of periphery lattice region **19520**.

[0067] FIG. 20 illustrates a front view of faceplate **20100** of a golf club head, where faceplate **20100** is subdivided into different cell lattice regions **20500** with one or more cell

lattices therewithin. In the present example, cell lattice regions **20500** comprise center lattice region **20510** and periphery lattice regions **20520**, where periphery lattice regions **20520** comprise heel lattice region **20521** and toe lattice region **20522**. Center lattice region **20510** is located at a center region of face plate **20100**, bounded at least partially by periphery lattice regions **20520**. Cell lattice regions **20500** can comprise or be similar to one or more of the cell lattices described herein, but can differ from each other with respect to at least one feature, such as in terms of stiffness, elasticity, and/or type of cell lattice comprised. As an example, center lattice region **20510** extends towards the top and bottom ends of faceplate **20100**, and can be otherwise similar to center lattice region **19510** (FIG. 19), while periphery lattice regions **20520** can be similar to periphery lattice region **19520** (FIG. 19). In the present examples, the cell lattices of periphery lattice regions **20520** can be similar to each other, but there can be other examples where such cell lattices may differ from each other.

[0068] In the present example, center lattice region **20510** can be stiffer than heel lattice region **20521** and toe lattice region **20522**, while the stiffnesses of heel lattice region **20521** and of toe lattice region **20522** can be similar to each other. There can also be examples, however, where the stiffnesses of heel lattice region **20521** can be greater than the stiffness of toe lattice region **20522**, or vice-versa. The ability to establish such different stiffness options for the different regions of faceplate **20100** can permit, for example, an optimization of ball speed due to differences in club head speed across the faceplate as induced by club head rotation about the golf shaft axis during swinging, the offsetting of a bias in average impact location, and/or the fine-tuning of the shape or position of the club head's target strike region. In addition, cell lattice regions **20500** are separated from each other by one or more boundary channels **20600** in the present example. Boundary channels **20600** are devoid of a cell lattice therewithin, but there also can be examples where boundary channels **20600** can comprise a cell lattice similar to one or more of the cell lattices described herein. In other examples, however, faceplate **20100** can be devoid of boundary channels **20600**, such that cell lattice regions **20500** contact or merge into each other.

[0069] FIG. 21 illustrates a front view of faceplate **21100** of a golf club head, where faceplate **21100** is subdivided into different cell lattice regions **21500** with one or more cell lattices therewithin. In the present example, cell lattice regions **21500** comprise center lattice region **21510** and periphery lattice regions **21520**, where periphery lattice regions **21520** comprise heel lattice region **21521**, toe lattice region **21522**, top lattice region **21523**, and bottom lattice region **21524**. Center lattice region **21510** is located at a center region of face plate **21100**, bounded at least partially by periphery lattice regions **21520**. Cell lattice regions **21500** can comprise or be similar to one or more of the cell lattices described herein, but can differ from each other with respect to at least one feature, such as in terms of stiffness, elasticity, and/or type of cell lattice comprised. As an example, center lattice region **20510** can be similar to center lattice region **19510** (FIG. 19) and/or to center lattice region **20510** (FIG. 20). Periphery lattice regions **21520** can be similar to periphery lattice region **19520** (FIG. 19) and/or to periphery lattice regions **20520** (FIG. 20). In the present example, the cell lattices comprised by periphery lattice regions **21520** differ from each other. For example, the cell lattices of top lattice

region **21523** and bottom lattice region **21524** differ from the cell lattices of heel lattice region **21521** and toe lattice region **21522**. In the same or other examples, the cell lattice of top lattice region **21523** can be similar to the cell lattice of bottom lattice region **21524**, while the cell lattice of toe lattice region **21522** can be similar to the cell lattice of heel lattice region **21521**. In other examples, however, the cell lattices of each of top lattice region **21523**, bottom lattice region **21524**, toe lattice region **21522**, and heel lattice region **21521** can all be similar to each other.

[0070] In the present example, center lattice region **21510** can be stiffer than periphery lattice regions **21520**. The stiffnesses of periphery lattice regions **21520** can be similar to each other or differ from each other, depending on the embodiment. For example, the stiffness of top lattice region **21523** and of bottom lattice region **21524** may be stiffer than the stiffnesses of heel lattice region **21521** and of toe lattice region **21522**, or vice-versa. There can also be examples where each of periphery lattice regions **21520** can comprise a different stiffness. The ability to establish such different stiffness options for the different regions of faceplate **21100** can permit further alternatives regarding benefits similar to those described above with respect to faceplate **20100**. In the present example, cell lattice regions **21500** are separated from each other by one or more boundary channels **21600**, which can be similar to boundary channels **20600** (FIG. 20).

[0071] FIG. 22 illustrates a front view of faceplate **22100** of a golf club head, where faceplate **22100** is subdivided into different cell lattice regions **22500** with one or more cell lattices therewithin. In the present example, cell lattice regions **22500** comprise center lattice region **22510** and periphery lattice regions **22520**, where periphery lattice regions **22520** comprise top-heel lattice region **22521**, top-toe lattice region **22522**, bottom-toe lattice region **22523**, and bottom-heel lattice region **22524**. Center lattice region **22510** is located at a center region of face plate **21100**, bounded at least partially by periphery lattice regions **22520**. Cell lattice regions **22500** can comprise or be similar to one or more of the cell lattices described herein, but can differ from each other with respect to at least one feature, such as in terms of stiffness, elasticity, and/or type of cell lattice comprised. In some examples, center lattice region **22510** can be similar to center lattice region **21510** (FIG. 21), while periphery lattice regions **22520** can be similar to periphery lattice regions **21520**, but shifted in terms of location across faceplate **22100**. In one example, the stiffnesses and/or cell lattices of top-heel lattice region **22521** and of top-toe lattice region **22522** may differ from the stiffnesses and/or cell lattices of bottom-heel lattice region **22524** and of bottom-toe lattice region **22523**. In another example, the stiffnesses and/or cell lattices of top-toe lattice region **22522** and of bottom-toe lattice region **22523** may differ from the stiffnesses and/or cell lattices of top-heel lattice region **22521** and of bottom-heel lattice region **22524**. There can also be embodiments where the stiffnesses and/or cell lattices of each of periphery lattice regions **22520** differ from each other. The ability to establish such different stiffness options for the different regions of faceplate **22100** can permit further alternatives regarding benefits similar to those described above with respect to faceplate **20100** and/or **21100**. In the present example, cell lattice regions **22500** are separated from each other by one or more boundary channels **22600**, which can be similar to boundary channels **20600** (FIG. 20).

[0072] Backtracking through the figures, FIG. 10 illustrates a flowchart for a method **10000** for providing a face plate for a golf club head. In some embodiments, the face plate can be similar to face plate **100** (FIGS. 1-4, 6), and or to a face plate comprising one or more cell lattices such as those described with respect to FIGS. 7-9, 11, and/or 12-11).

[0073] Block **10100** of method **10000** comprises providing an inner skin of the face plate. Block **10200** of method **10000** comprises providing an outer skin of the face plate. In some examples, the inner skin of block **10100** can be similar to inner skin **210**, while the outer skin of block **10200** can be similar to outer skin **120** (FIGS. 2-3). In the same or other examples, block **10100** may comprise providing first and second inner skin layers of the inner skin, where such first and second inner skin layers may be similar to inner skin layers **310** (FIG. 3). In the same or other examples, block **10200** may comprise providing first and second outer skin layers of the outer skin, where such first and second outer skin layers may be similar to outer skin layers **320** (FIG. 3).

[0074] Block **10300** of method **10000** comprises providing a midsection of the face plate. In some examples, the midsection can be similar to midsection **230** (FIGS. 1-4, 6) and/or midsection **930** (FIG. 9). In the same or other examples, block **10300** can comprise sub-block **10310** for providing first and second midsection layers of the midsection of block **10300**. There can be examples where the first and second midsection layers can be similar to midsection layers **330** (FIG. 3). In the present example, the inner skin of block **10100**, the outer skin of block **10200**, and the midsection of block **10300** are provided as separate distinct portions, although there can be other embodiments where two of them may be provided already combined together.

[0075] In some examples, block **10300** can also comprise sub-block **10320** for forming a cell lattice in the midsection, the cell lattice comprising a plurality of walls defining a plurality of cells. In some examples, the cell lattice can be similar to cell lattice **240** of midsection **230** (FIGS. 2-6), to one or more of cell lattices **740** (FIG. 7), **840** (FIG. 8), **940** (FIG. 9), **1140** (FIG. 11), **1240** (FIG. 12), **1340** (FIG. 13), **1440** (FIG. 14), **1540** (FIG. 15), **1640** (FIG. 16), **17240** (FIG. 17), and/or **18240** (FIG. 18), to one or more of the cell lattices comprised by the cell lattice regions of faceplate **19100** (FIG. 19), **20100** (FIG. 20), **21100** (FIG. 21), and/or **22100** (FIG. 22), and/or to other cell lattice variations similar to those described herein.

[0076] Sub-block **10320** may comprise sub-block **10321** for forming a first lattice pattern of the cell lattice through the first midsection layer, and/or sub-block **10322** for forming a second lattice pattern of the cell lattice through the second midsection layer. In some examples, the first lattice pattern of sub-block **10321** can be similar to cell lattice pattern **341** through midsection layer **331** (FIGS. 3-4). In the same or other examples, the second lattice pattern of sub-block **10322** can be similar to another lattice pattern of another midsection layer, such as lattice pattern **242** of midsection layer **332** (FIG. 3). There can also be examples where the first and second lattice patterns of sub-blocks **10321-10322** can correspond to lattice patterns for the cell lattices of FIG. 7-9 or 11-22, and/or to other cell lattice variations similar to those described herein.

[0077] Sub-block **10321** may comprise forming a first cutout through the first midsection layer, where the first cutout is configured to define a first volume portion of a first cell of the cell lattice. Similarly, sub-block **10322** may comprise form-

ing a second cutout through the second midsection layer, where the second cutout is configured to define a second volume portion of the first cell of the cell lattice. As an example, the first cutout may be similar to cutout 342 through midsection layer 331 (FIG. 3), and the second cutout can be similar to cutout 343 through midsection layer 332 (FIG. 3) so that, when midsection layers 330 are coupled together, such as through sub-block 10411 (below), the volumes defined by cutouts 342 and 343 will combine to define at least part of the volume of a cell of cell lattice 240. There can be examples where sub-block 10322 can comprise forming the second cutout to comprise a different dimension than the first cutout, such as a different radius, a different perimeter length, a different area, or a different volume. Accordingly, the first and second cutouts need not be equal to each other, thereby adding flexibility to further define desired features for the volume and/or shape of the cells of the cell lattice.

[0078] In some examples, forming the cell lattice in block 10320 can comprise aligning the second midsection layer over the first midsection layer such that the first and second cutouts are centered about a first cell axis of a cell of cell lattice 240. As an example, as described above with respect to FIGS. 3-4, midsection layers 300 comprise respective alignment elements 351-354, and can be aligned with each other by aligning respective alignment members 351-354 throughout the stack of midsection layers 300. Accordingly, cutout 342 of layer 331 and cutout 343 of layer 332 end up aligned relative to each other by being centered about cell axis 350, where cell axis 350 traverses through stacked cutouts of layers 330 to define a cell of cell lattice 240 in midsection 230. In some examples, the alignment elements can comprise features such as holes and/or indentions that can match each other for alignment by corresponding shape and/or by location. With respect to the example of FIGS. 3-4, alignment elements 351-354 are offset relative to each other to permit alignment of adjacent ones of layers 300 only in a single orientation.

[0079] There can also be examples where not all cutouts of stacked layers of the midsection need be aligned with each other centered about a cell axis. In some embodiments, the cutouts and/or cells of the cell lattice may be offset from each other. For instance, forming the first lattice pattern in block 10321 can comprise forming the first cutout through the first midsection layer to define a first volume portion of the first cell, and forming the second lattice pattern block 10322 can comprise forming the second cutout through the second midsection layer to define a second volume portion of a second cell of the cell lattice. In the same or other examples, the second cell can be at least partially capped or defined by solid portions of the first midsection layer and/or the outer skin, and/or the first cell can be at least partially capped or defined by solid portions of the second midsection layer and/or the inner skin. For instance, as shown in FIG. 9, midsection layers 931-933 can be aligned and stacked relative to each other such that cells 9421, 9422, and 9423 are offset from each other, such that cell 9421 is at least partially capped or defined by solid portion 9321 of layer 932, and cell 9422 is at least partially capped or defined by solid portion 9311 of layer 931. Although midsection 930 is shown in FIG. 9 as layers 931-933 for simplicity, layers 931-933 may each represent a plurality of midsection layers stacked together in the same or other embodiments.

[0080] Block 10400 of method 10000 comprises coupling the midsection of block 10300 between the inner skin of block

10100 and the outer skin of block 10200. In some examples, the midsection may comprise an inner midsection end coupled to the inner skin of block 10100, and an outer midsection end coupled to the outer skin of block 10200, such that the midsection is "sandwiched" therebetween. In the same or other examples, block 10400 can comprise sub-block 10410 for merging the inner skin, the midsection, and the outer skin together into a single integral piece of material without adhesives or fasteners. For instance, the inner skin, the midsection, and the outer skin may be merged together via a high-heat and high-pressure process as described above with respect to FIGS. 2-3, such as via a diffusion bonding process. There can be embodiments where sub-block 10410 can be carried out such that the single integral piece of material is seamless between the inner skin and the midsection, and between the midsection and the outer skin. In the same or other examples, sub-block 10410 can comprise sub-block 10411 for merging the first midsection layer and the second midsection layer together integrally into the single piece of material. As an example, sub-block 10411 can comprise merging midsection layers 330 together (FIG. 3) as described above. In the same or other examples, sub-block 10410 can also comprise merging inner skin layers 310 (FIG. 3) together, and/or merging outer skin layers 320 (FIG. 3) together into the single piece of material for the faceplate.

[0081] Such seamless and single-piece merging between the inner skin, the mid section and the outer skin, and/or between their respective layers, can occur when the merging occurs at the molecular level. For example, the inner skin, the midsection, and the outer skin can all be provided to comprise the same metallic material, where such material can be selected to be suitable for merging the different portions of the faceplate at the molecular level when exposed to a high heat and high-pressure process, such as through a diffusion bonding process. In some examples, the metallic material can comprise a metallic alloy, as described above, and the merging at the molecular level can take advantage of the crystal structure of the metallic material to achieve integral bonding to generate the single piece of material for the faceplate. As an example, the inner skin may be provided in block 10100 to comprise a first crystal structure of an alpha-type structure; the outer skin may be provided in block 10200 to comprise a second crystal structure of the alpha-type structure; and the midsection may be provided in block 10300 to comprise a midsection crystal structure of the alpha-type structure. Then, at block 10400, the first crystal structure of the inner skin, the second crystal structure of the outer skin, and the midsection crystal structure of the midsection can be transformed into a beta-type structure such that the midsection crystal structure is intermeshed with the first crystal structure, and the midsection crystal structure is intermeshed with the second crystal structure. In some examples, the alpha-type structure can comprise a hexagonal crystal phase, and the beta-type structure can comprises a body-centered cubic crystal phase.

[0082] Block 10500 of method 10000 can be optional, comprising coupling the face plate to a front end of the golf club head. In some examples, the golf club head can be similar to golf club head 10 as illustrated in FIG. 1. The faceplate can be coupled by mating a faceplate edge, such as faceplate edge 101 (FIGS. 1-2) to an opening at the front of the golf club head. In some examples, such mating can be achieved via a welding process and/or a brazing process.

[0083] In some examples, the cell lattice of the midsection, as formed in sub-block 10320, can be located in a central

midsection area of the midsection, such that a perimeter midsection area of the midsection bounding the central midsection area can be devoid of the cell lattice and/or of its cells. As an example, the perimeter midsection area can be similar to perimeter midsection area **232** of midsection **230** bounding the central area of midsection **230** comprising cell lattice **240** (FIGS. **1-4**). In some embodiments, perimeter midsection area **230** can separate the cell lattice **240** in the central midsection area away from faceplate edge **101** by at least approximately 0.1 inches (2.54 mm).

[0084] In the same or other examples, coupling the face plate in block **10500** can comprise coupling the front end of the golf club head to an inner skin perimeter area of the inner skin of block **10100**, such as to inner skin perimeter area **212** (FIG. **2**), or to an outer skin perimeter area of the outer skin of block **10200**, such as to outer skin perimeter area **222** (FIG. **2**), or to both. For instance, the inner skin perimeter area and/or the outer skin perimeter area can be aligned with the perimeter midsection area described above such as not to contact the cell lattice of the midsection central area. There can be other examples, however, where the cell lattice can extend throughout the midsection area of the faceplate, such that the inner and outer skin perimeter areas would thus contact the cell lattice.

[0085] The cell lattice formed in block **10320** can comprise one or more of several characteristics. For example, the plurality of cells of the cell lattice can be formed in a hexagonal pattern, such as seen in FIGS. **4** and **6-7** with respect to cell lattice **240**. In the same or other examples, the cell lattice can be formed in an isogrid pattern, as also seen with respect to cell lattices **240** and **740**. The cell lattice can comprise in the same or other examples a plurality of cell junctions where two or more of the plurality of walls couple together. For instance, the cell junctions can be similar to cell junction **443** (FIGS. **4**, **6**) and/or to cell junction **743** (FIG. **7**). One or more of the cell junctions may comprise a junction channel extending from the inner midsection end to the outer midsection end of the midsection, such as junction channel **4431** extended from inner midsection end **245** to outer midsection end **246** through cell junction **443**, as shown in FIG. **6**.

[0086] Continuing with examples of the one or more several characteristics for the cell lattice in block **10320**, there can also be embodiments where forming the cell lattice can comprise forming one or more walls of the cell lattice to comprise a varying dimension. As an example, the cell lattice can comprise a wall, such as one of walls **741** having varying length thickness dimensions (FIG. **7**), and/or such as one of walls **841** and/or **1141** having varying depth thickness dimensions (FIGS. **8** and **11**). In the same or other examples, forming the cell lattice can comprise forming the plurality of cells in a diminishing density pattern and/or in a diminishing size pattern. For instance, in the diminishing size pattern, the plurality of cells can decrease in size or dimension towards a target strike region of the face plate, such as shown and described with respect to FIGS. **17-18**. In the diminishing density pattern, the plurality of cells can decrease in density towards the target strike region of the face plate.

[0087] In the same or other examples, the cell lattice can comprise one or more transverse passageways between adjacent cells of the cell lattice. As an example, the cell lattice can comprise transverse passageways as shown in FIG. **6**, where transverse passageway **644** traverses through wall **6411** between adjacent cells of cells **242**. In the same or other examples, the formation of the transverse passageways can be

facilitated, for example, by the layered formation of midsection **230** (FIGS. **1-4**, **6**), where the features of transverse passageways such as transverse passageway **644** can be formed in block **10300** for each of midsection layers **330** prior to carrying out block **10400**.

[0088] There can also be examples where a single faceplate can comprise a plurality of cell lattice regions, such as described with respect to FIGS. **19-22**. In some examples, the cell lattice regions of the plurality of cell lattice regions can be similar to each other. In other examples, two or more of the cell lattice regions of the plurality of cell lattice regions can differ from each other with respect to at least one feature, such as in terms of stiffness, elasticity, and/or type of cell lattice comprised.

[0089] In some examples, one or more of the different blocks of method **10000** can be combined into a single block or performed simultaneously, and/or the sequence of such blocks can be changed. For example, the inner skin of block **10100** may be provided simultaneously with the midsection of block **10300**, and/or the outer skin of block **10200** may be provided simultaneously with the midsection of block **10300**. As another example, the sequence of sub-blocks **10321** and **10322** can be changed.

[0090] In the same or other examples, some of the blocks of method **10000** can be subdivided into several sub-blocks. For example, block **10500** may comprise a sub-block for fastening the face plate to the front end of the golf club head, and another sub-block for polishing the faceplate and/or the junction with the front end of the golf club head. There can also be examples where method **10000** can comprise further or different blocks. In addition, there may be examples where method **10000** can comprise only part of the steps described above. For instance, block **10500** can be optional in some examples. Other variations can be implemented for method **10000** without departing from the scope of the present disclosure.

[0091] Although the golf club face plates with internal cell lattices and related methods herein have been described with reference to specific embodiments, various changes may be made without departing from the spirit or scope of the present disclosure. For example, although golf club head **10** is illustrated in FIG. **1** as a driver club head, the disclosure herein is also applicable to other types of golf club heads, such as fairway woods, hybrids, and even club heads without internal cavities such as putters and irons. Additional examples of such changes have been given in the foregoing description. Other permutations of the different embodiments having one or more of the features of the various figures are likewise contemplated. Accordingly, the specification, claims, and drawings herein are intended to be illustrative of the scope of the disclosure and is not intended to be limiting. It is intended that the scope of this application shall be limited only to the extent required by the appended claims.

[0092] The golf club face plates with internal cell lattices and related methods discussed herein may be implemented in a variety of embodiments, and the foregoing discussion of certain of these embodiments does not necessarily represent a complete description of all possible embodiments. Rather, the detailed description of the drawings, and the drawings themselves, disclose at least one preferred embodiment, and may disclose alternative embodiments.

[0093] All elements claimed in any particular claim are essential to the embodiment claimed in that particular claim. Consequently, replacement of one or more claimed elements

constitutes reconstruction and not repair. Additionally, benefits, other advantages, and solutions to problems have been described with regard to specific embodiments. The benefits, advantages, solutions to problems, and any element or elements that may cause any benefit, advantage, or solution to occur or become more pronounced, however, are not to be construed as critical, required, or essential features or elements of any or all of the claims, unless such benefits, advantages, solutions, or elements are expressly stated in such claims.

[0094] As the rules to golf may change from time to time (e.g., new regulations may be adopted or old rules may be eliminated or modified by golf standard organizations and/or governing bodies such as the United States Golf Association (USGA), the Royal and Ancient Golf Club of St. Andrews (R&A), etc.), golf equipment related to the apparatus, methods, and articles of manufacture described herein may be conforming or non-conforming to the rules of golf at any particular time. Accordingly, golf equipment related to the apparatus, methods, and articles of manufacture described herein may be advertised, offered for sale, and/or sold as conforming or non-conforming golf equipment. The apparatus, methods, and articles of manufacture described herein are not limited in this regard.

[0095] While the above examples may be described in connection with a driver-type golf club, the apparatus, methods, and articles of manufacture described herein may be applicable to other types of golf club such as a fairway wood-type golf club, a hybrid-type golf club, an iron-type golf club, a wedge-type golf club, or a putter-type golf club. Alternatively, the apparatus, methods, and articles of manufacture described herein may be applicable other type of sports equipment such as a hockey stick, a tennis racket, a fishing pole, a ski pole, etc.

[0096] Moreover, embodiments and limitations disclosed herein are not dedicated to the public under the doctrine of dedication if the embodiments and/or limitations: (1) are not expressly claimed in the claims; and (2) are or are potentially equivalents of express elements and/or limitations in the claims under the doctrine of equivalents.

What is claimed is:

1. A method for providing a face plate for a golf club head, the method comprising:

- providing an inner skin of the face plate;
- providing an outer skin of the face plate;
- providing a midsection of the face plate; and
- bounding the midsection between the inner skin and the outer skin;

wherein:

- providing the midsection comprises:
 - providing a plurality of midsection layers comprising a first midsection layer and a second midsection layer;
 - forming a first lattice pattern through the first midsection layer; and
 - forming a second lattice pattern through the second midsection layer;

providing the inner skin, the outer skin, and the midsection comprises:

- providing each of the midsection, the inner skin, or the outer skin as separate distinct pieces;

bounding the midsection comprises:

- diffusion bonding the inner skin, the midsection, and the outer skin together, including the first and second midsection layers, into a single integral piece of material that is substantially seamless between the inner skin and the midsection and between the midsection and the outer skin;

wherein after the diffusion bonding:

- a midsection central area of the midsection comprises a cell lattice;
- the cell lattice comprises a plurality of walls defining a plurality of cells in a hexagonal pattern;
- the plurality of walls and the plurality of cells of the cell lattice are defined at least in part by the first and second lattice patterns;
- the cell lattice is fully bounded between the inner and outer skins of the face plate; and
- a midsection perimeter area of the midsection bounds the midsection central area and is devoid of the cell lattice;

forming the first lattice pattern through the first midsection layer comprises forming a first cutout through the first midsection layer, the first cutout configured to define a first volume portion of a first cell of the cell lattice;

forming the second lattice pattern through the second midsection layer comprises forming a second cutout through the second midsection layer, the second cutout configured to define a second volume portion of the first cell;

and

bounding the midsection comprises:

- aligning the second midsection layer over the first midsection layer such that the first and second cutouts are centered about a first cell axis of the first cell.

2. The method of claim 1, wherein:

bonding the midsection comprises forming the plurality of cells in an isogrid pattern;

diffusion bonding the inner skin, the midsection, and the outer skin together comprises intermeshing interfaces between the inner skin, the midsection, and the outer skin together via a high-pressure and high-heat process; providing the inner skin, the outer skin, and the midsection comprises;

- providing the midsection, the inner skin, and the outer skin to each comprise a titanium alloy with an alpha-type crystal structure;

and

diffusion bonding the inner skin, the midsection, and the outer skin together comprises

- transforming the alpha-type crystal structure of the midsection, the inner skin, and the outer skin to a beta-type crystal structure intermeshing the midsection, the inner skin, and the outer skin together;
- the alpha-type structure comprising a hexagonal crystal phase; and
- the beta-type structure comprises a body-centered cubic crystal phase.

3. A method for providing a face plate for a golf club head, the method comprising:

- providing an inner skin of the face plate;
- providing an outer skin of the face plate;
- providing a midsection of the face plate; and
- coupling the midsection between the inner skin and the outer skin such that:

- an inner midsection end of the midsection is coupled to the inner skin of the face plate; and
- an outer midsection end of the midsection is coupled to the outer skin of the face plate;

wherein:

providing the midsection comprises:

providing a cell lattice in the midsection, the cell lattice comprising a plurality of walls defining a plurality of cells.

4. The method of claim 3, wherein:

coupling the midsection comprises:

merging the inner skin, the midsection, and the outer skin together into a single integral piece of material without adhesives or fasteners.

5. The method of claim 4, wherein:

the single integral piece of material is seamless between the inner skin and the midsection and between the midsection and the outer skin.

6. The method of claim 4, wherein:

coupling the midsection comprises:

merging the inner skin, the midsection, and the outer skin together via diffusion bonding using a high-pressure and high-heat process.

7. The method of claim 3, wherein:

the midsection comprises a metallic material; and the inner skin and the outer skin comprise the metallic material.

8. The method of claim 6, wherein:

the metallic material comprises a titanium alloy comprising at least approximately 8% aluminum.

9. The method of claim 3, wherein:

prior to coupling the midsection between the inner skin and the outer skin;

the inner skin comprises a first crystal structure of an alpha-type structure;

the outer skin comprises a second crystal structure of the alpha-type structure; and

the midsection comprises a midsection crystal structure of the alpha-type structure; and

coupling the midsection between the inner skin and the outer skin comprises:

transforming the first crystal structure, the second crystal structure, and the mid-crystal structure to a beta-type structure such that:

the midsection crystal structure is intermeshed with the first crystal structure; and

the midsection crystal structure is intermeshed with the second crystal structure.

10. The method of claim 3, wherein:

providing the cell lattice comprises:

providing the cell lattice extended from the inner midsection end to the outer midsection end.

11. The method of claim 3, wherein:

providing the midsection comprises:

forming the cell lattice in a midsection central area of the midsection; and

providing a midsection perimeter area of the midsection bounding the midsection central area and devoid of the cell lattice.

12. The method of claim 11, further comprising:

coupling the face plate to a front end of the golf club head; wherein coupling the face plate to the front end of the golf club head comprises:

coupling the front end of the golf club head to at least one of:

an inner skin perimeter area of the inner skin; or

an outer skin perimeter area of the outer skin;

the inner skin perimeter area and the outer skin perimeter area being coupled to the midsection perimeter area without contacting the cell lattice at the midsection central area.

13. The method of claim 3, wherein:

providing the cell lattice comprises forming one or more of the plurality of cells with at least one of a hexagonal shape, a diamond shape, a rectangular shape, a circular shape, or a triangular shape.

14. The method of claim 3, wherein:

providing the cell lattice comprises:

providing cells of a first set of the plurality of cells with a first geometric shape; and

providing cells of a second set of the plurality of cells with a second geometric shape different than the first geometric shape; and

providing the first set of the plurality of cells interspersed with the second set of the plurality of cells.

15. The method of claim 3, wherein:

providing the cell lattice comprises forming one or more subcells within one or more of the plurality of cells.

16. The method of claim 3, wherein:

forming the cell lattice comprises forming the plurality of cells in an isogrid pattern.

17. The method of claim 3, wherein:

providing the cell lattice comprises:

providing a plurality of cell junctions where two or more of the plurality of walls couple together; and

forming a first junction channel into a first cell junction of the plurality of cell junctions, the first junction channel extending from the inner midsection end to the outer midsection end.

18. The method of claim 3, wherein:

providing the cell lattice comprises:

forming a first wall of the plurality of walls to comprise a transverse passageway between adjacent cells of the plurality of cells.

19. The method of claim 3, wherein:

providing the cell lattice comprises:

forming a first wall of the plurality of walls to comprise a varying wall dimension.

20. The method of claim 3, wherein:

providing the cell lattice comprises forming the plurality of cells in at least one of:

a first pattern where a density of the plurality of cells decreases towards a target strike region of the face plate; or

a second pattern where a size of the plurality of cells decreases towards the target strike region of the face plate.

21. The method of claim 3, wherein:

providing the midsection comprises:

providing a plurality of midsection layers comprising:

a first midsection layer; and

a second midsection layer;

providing the cell lattice in the midsection comprises:

forming a first lattice pattern of the cell lattice through the first midsection layer; and

forming a second lattice pattern of the cell lattice through the second midsection layer; and

coupling the midsection between the inner skin and the outer skin comprises:

merging the first midsection layer and the second midsection layer together integrally into a single piece of material.

22. The method of claim 21, wherein:

providing the cell lattice comprises forming a first cell of the plurality of cells;

forming the first lattice pattern through the first midsection layer comprises:
 forming a first cutout through the first midsection layer, the first cutout configured to define a first volume portion of the first cell;

and

forming the second lattice pattern through the second midsection layer comprises:
 forming a second cutout through the second midsection layer, the second cutout configured to define a second volume portion of the first cell.

23. The method of claim **22**, wherein:

forming the second cutout comprises:
 forming the second cutout to comprise a different dimension than the first cutout, the different dimension comprising at least one of:
 a different radius, a different perimeter length, a different area, or a different volume.

24. The method of claim **22**, wherein:

prior to merging the first midsection layer and the second midsection layer together:
 forming the cell lattice comprises:
 aligning the second midsection layer over the first midsection layer such that the first and second cutouts are centered about a first cell axis of the first cell.

25. The method of claim **21**, wherein:

providing the cell lattice comprises forming a first cell of the plurality of cells;
 forming the first lattice pattern through the first midsection layer comprises:
 forming a first cutout through the first midsection layer, the first cutout configured to define a first volume portion of the first cell;

prior to merging the first midsection layer and the second midsection layer together:

forming the second lattice pattern of the cell lattice through the second midsection layer comprises:
 forming a second cutout through the second midsection layer, the second cutout configured to define a second volume portion of a second cell of the cell lattice;

and

providing the cell lattice further comprises:
 aligning the first midsection layer over the second midsection layer such that:

the first and second cells are offset relative to each other;
 the second cell is at least partially capped by a solid portion of the first midsection layer; and
 the first cell is at least partially capped by a solid portion of the second midsection layer.

26. A face plate for a golf club head, the face plate comprising:

an inner skin;
 an outer skin; and
 a midsection comprising:
 an inner midsection end coupled to the inner skin;
 an outer midsection end coupled to the outer skin; and
 a cell lattice comprising a plurality of walls defining a plurality of cells between the inner midsection end and the outer midsection end.

27. The face plate of claim **26**, further comprising:

a face plate central area; and
 a face plate perimeter area between the face plate central area and a perimeter of the face plate;

wherein:

the inner skin comprises a first crystal structure;
 the outer skin comprises a second crystal structure;
 the midsection comprises a plurality of midsection layers having a midsection crystal structure;
 the inner skin, the outer skin, and the midsection, along with the plurality of midsection layers, comprise a single piece of material;
 the midsection comprises a metallic material;
 the inner skin and the outer skin comprise the metallic material;
 the cell lattice is located in the face plate central area without extending into the face plate perimeter area; and
 the cell lattice comprises a hexagonal pattern defined by the plurality of walls.

28. The face plate of claim **27**, further comprising:

the metallic material comprises a titanium alloy comprising at least approximately 8% aluminum;
 the first, second, and midsection crystal structures comprise a beta-type structure having a body-centered cubic crystal phase; and
 the cell lattice comprises an isogrid pattern defined by the plurality of walls and the plurality of cells.

* * * * *