



US 20130045816A1

(19) **United States**

(12) **Patent Application Publication**  
**Lewis et al.**

(10) **Pub. No.: US 2013/0045816 A1**

(43) **Pub. Date: Feb. 21, 2013**

(54) **GOLF CLUB GRIP**

**Related U.S. Application Data**

(75) Inventors: **James G. Lewis**, Carlsbad, CA (US);  
**Austin B. Oliveira**, San Marcos, CA  
(US); **Michael T. McDonnell**, Carlsbad,  
CA (US); **Jesse S. Bolane**, San Marcos,  
CA (US); **Robert A. Phillion**, Carlsbad,  
CA (US); **Thomas W. Preece**, San  
Diego, CA (US); **Douglas E. Roberts**,  
Carlsbad, CA (US)

(60) Provisional application No. 61/525,358, filed on Aug.  
19, 2011.

**Publication Classification**

(51) **Int. Cl.**  
*A63B 53/14* (2006.01)  
*A63B 53/02* (2006.01)  
(52) **U.S. Cl.** ..... **473/201; 473/300; 473/303; 473/314**

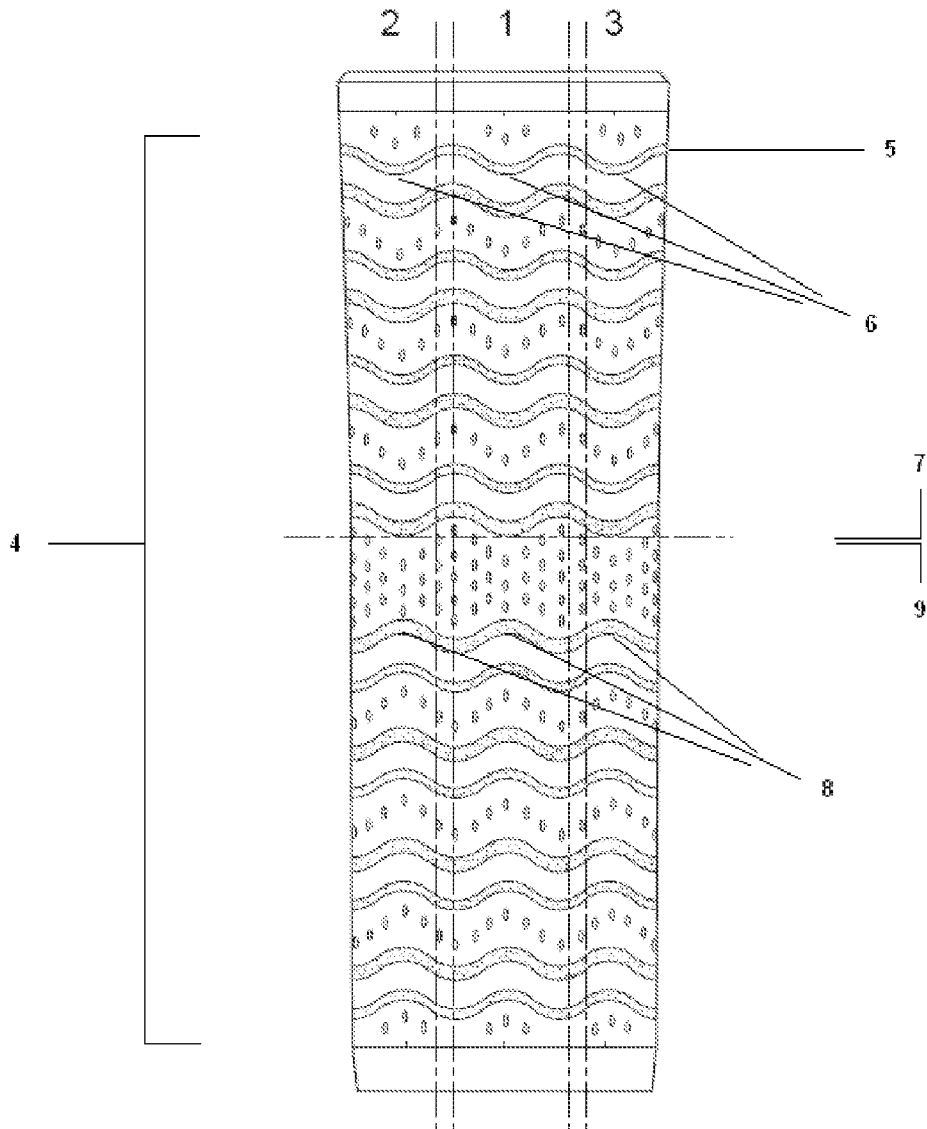
(73) Assignee: **COBRA GOLF INCORPORATED**,  
Carlsbad, CA (US)

(57) **ABSTRACT**

The invention generally relates to a grip for a golf club. In certain embodiments, the invention provides a golf club grip having a pattern such that a view of the grip is identical to a user for every position of a multi-positional club head of a golf club.

(21) Appl. No.: **13/366,778**

(22) Filed: **Feb. 6, 2012**



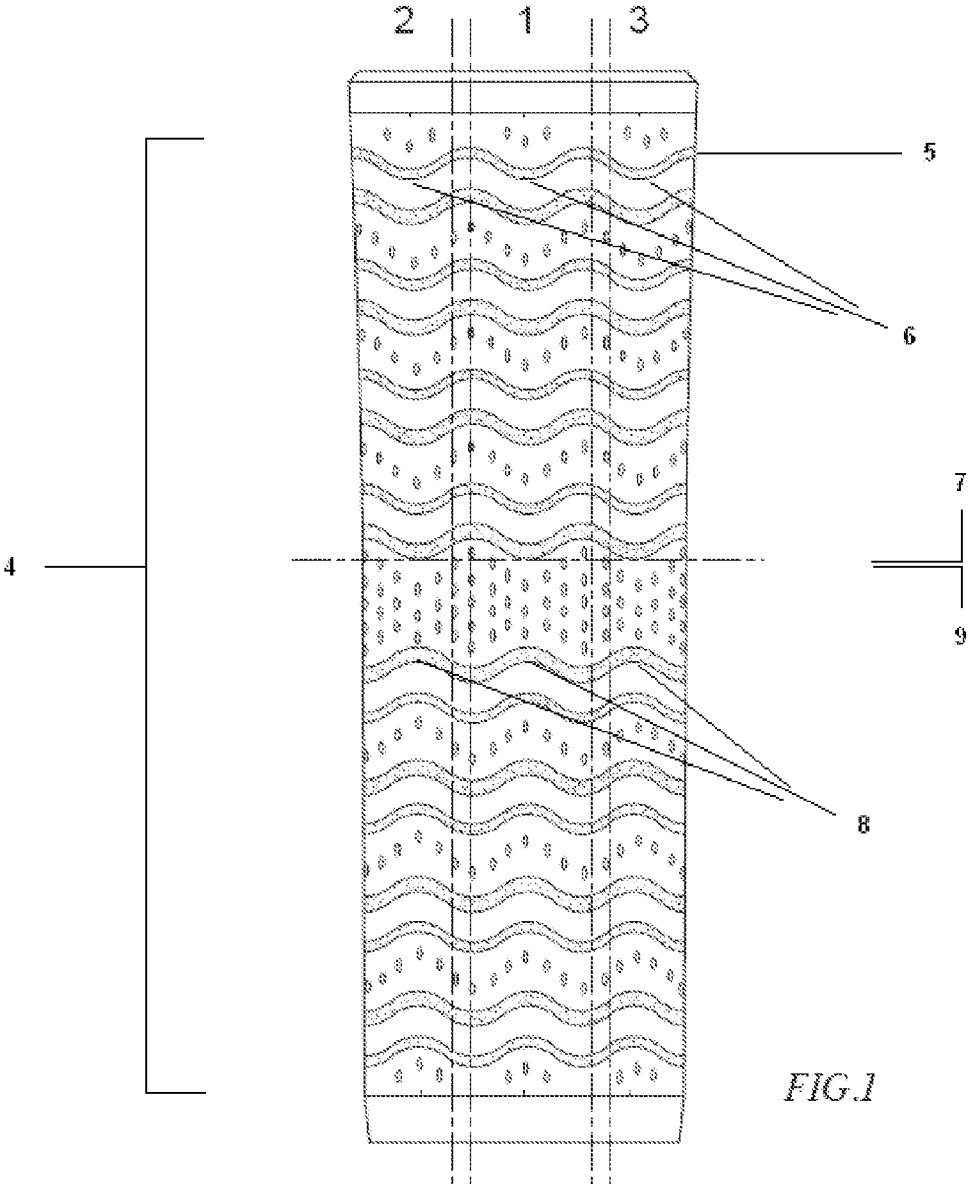


FIG. 1

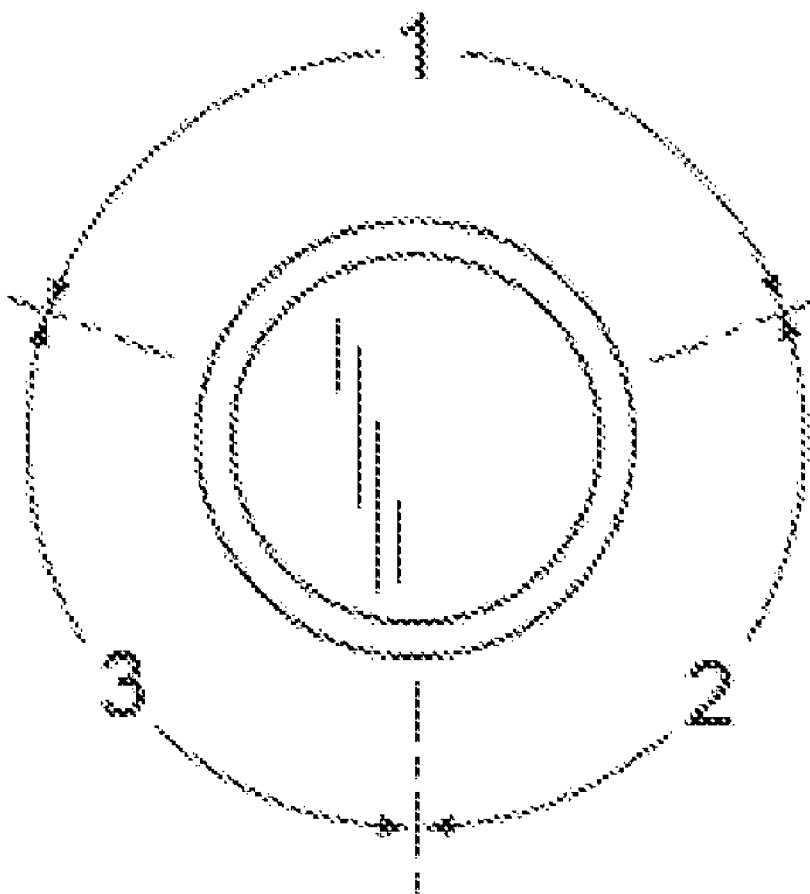
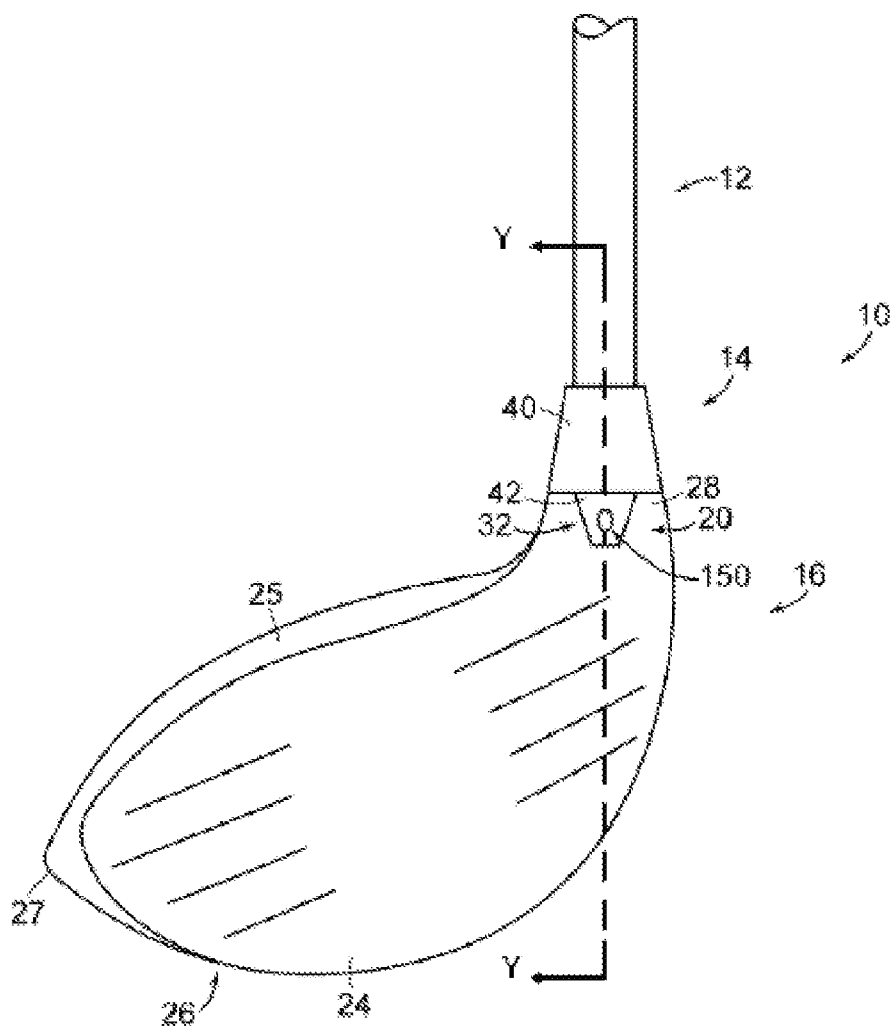
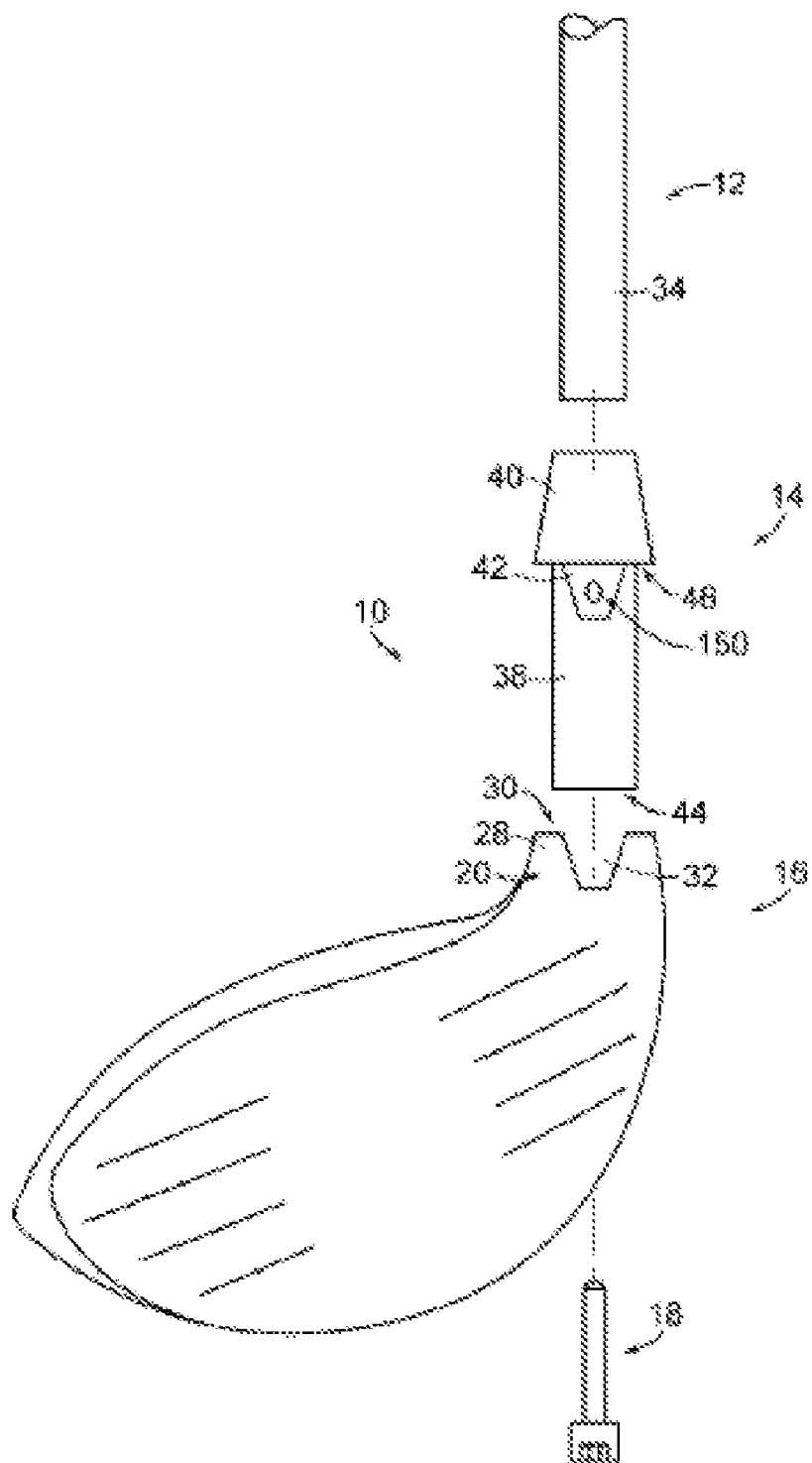


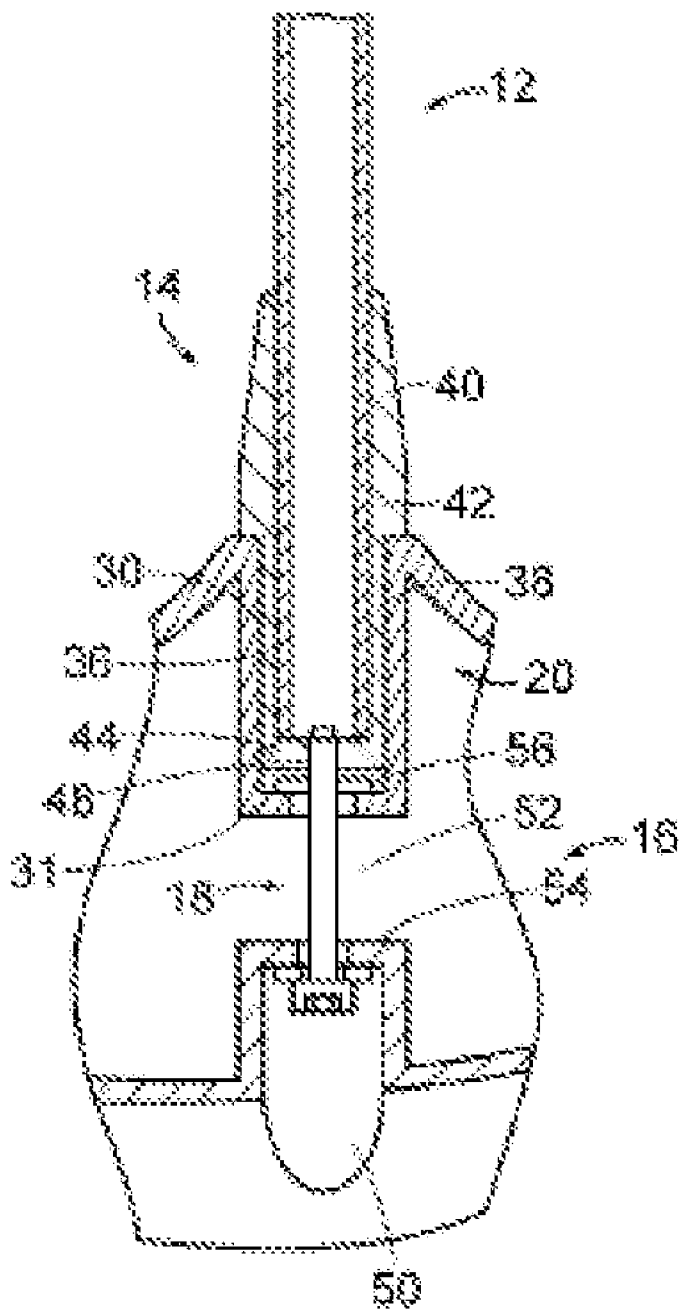
FIG 2



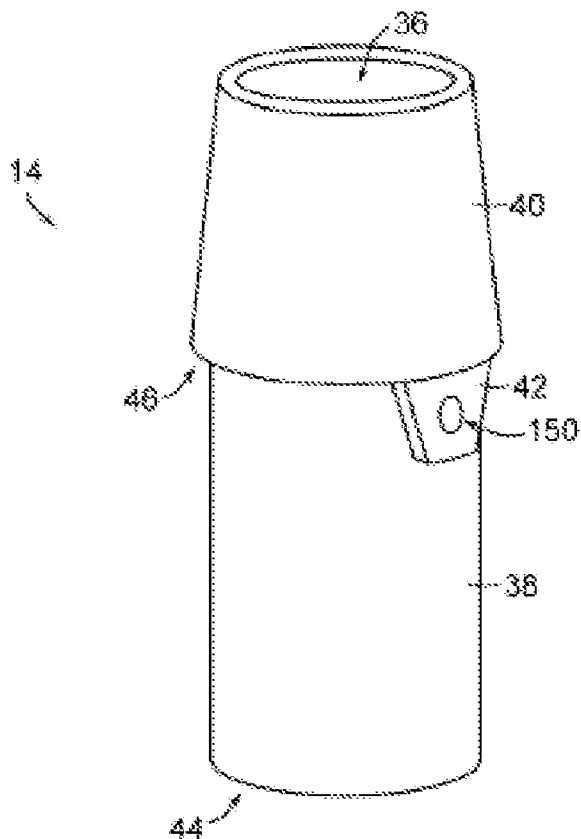
**FIG. 3**



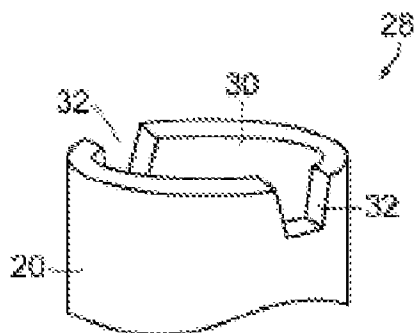
**FIG. 4**



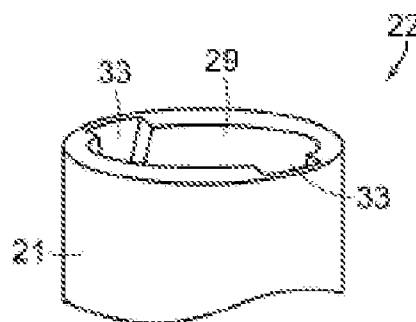
**FIG. 5**



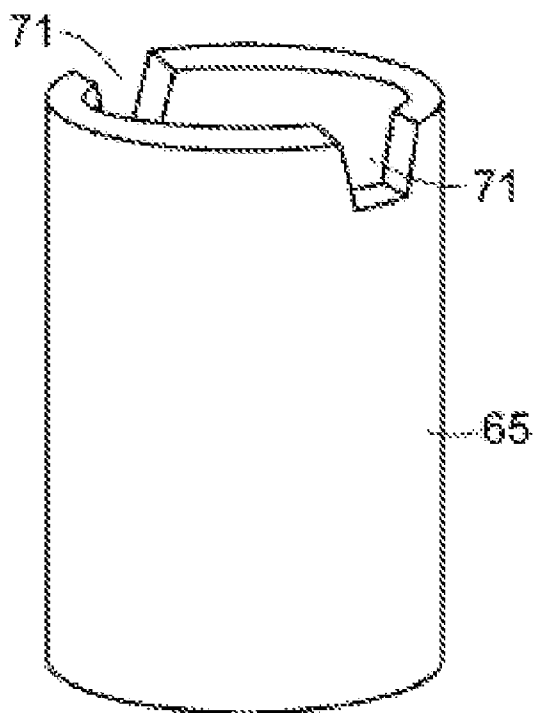
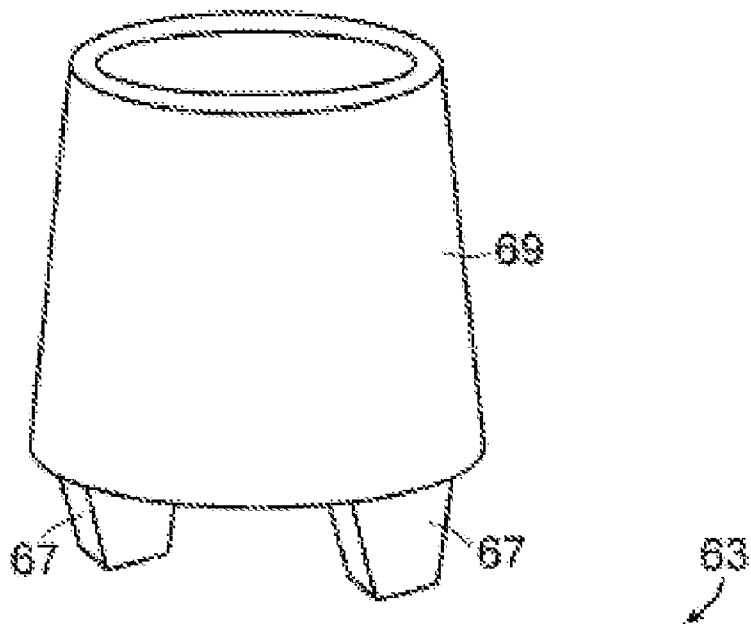
**FIG. 6**



**FIG. 7**

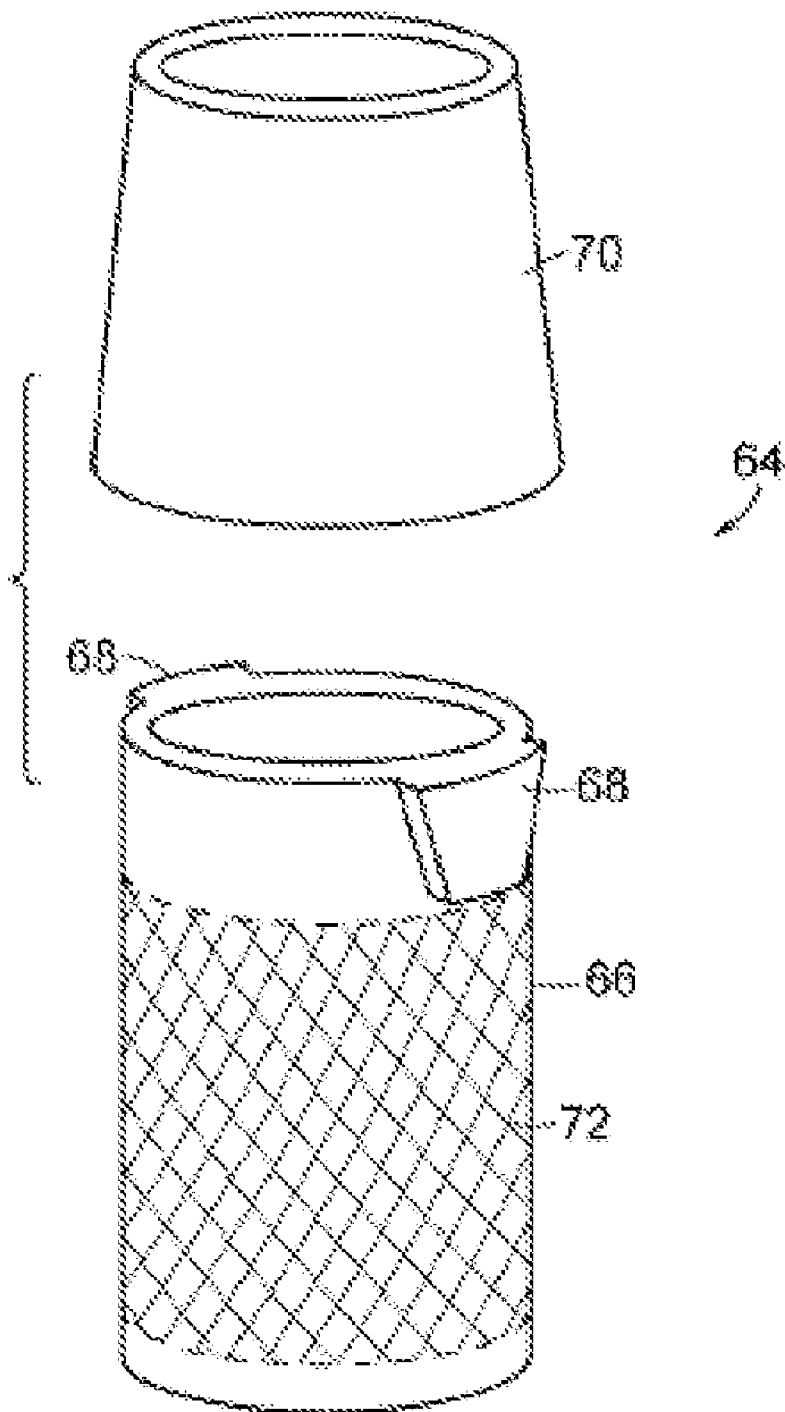


**FIG. 8**

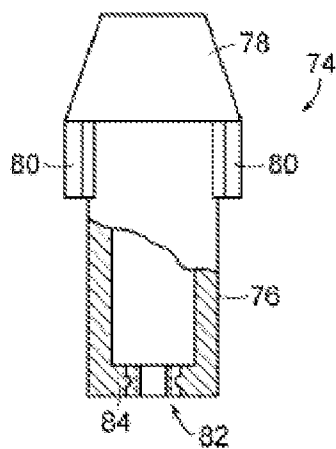


**FIG. 9**

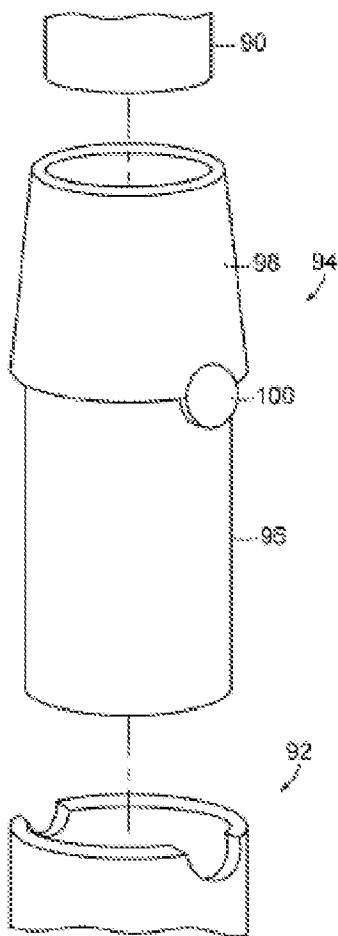




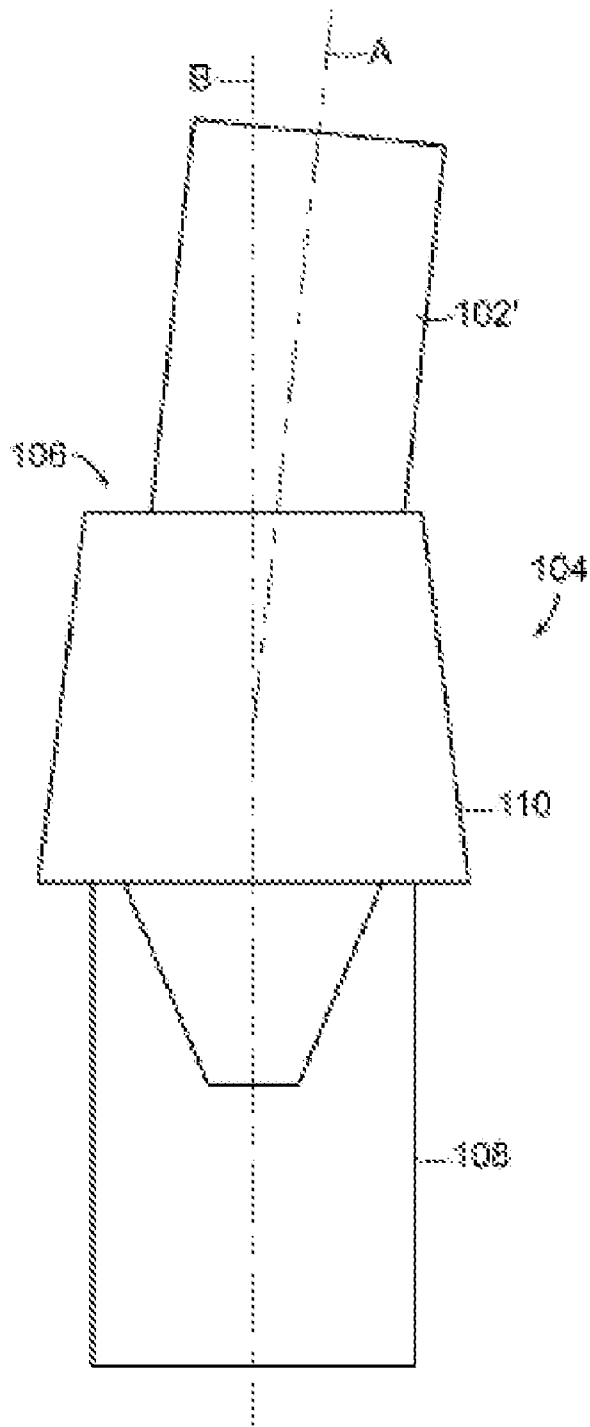
**FIG. 10**



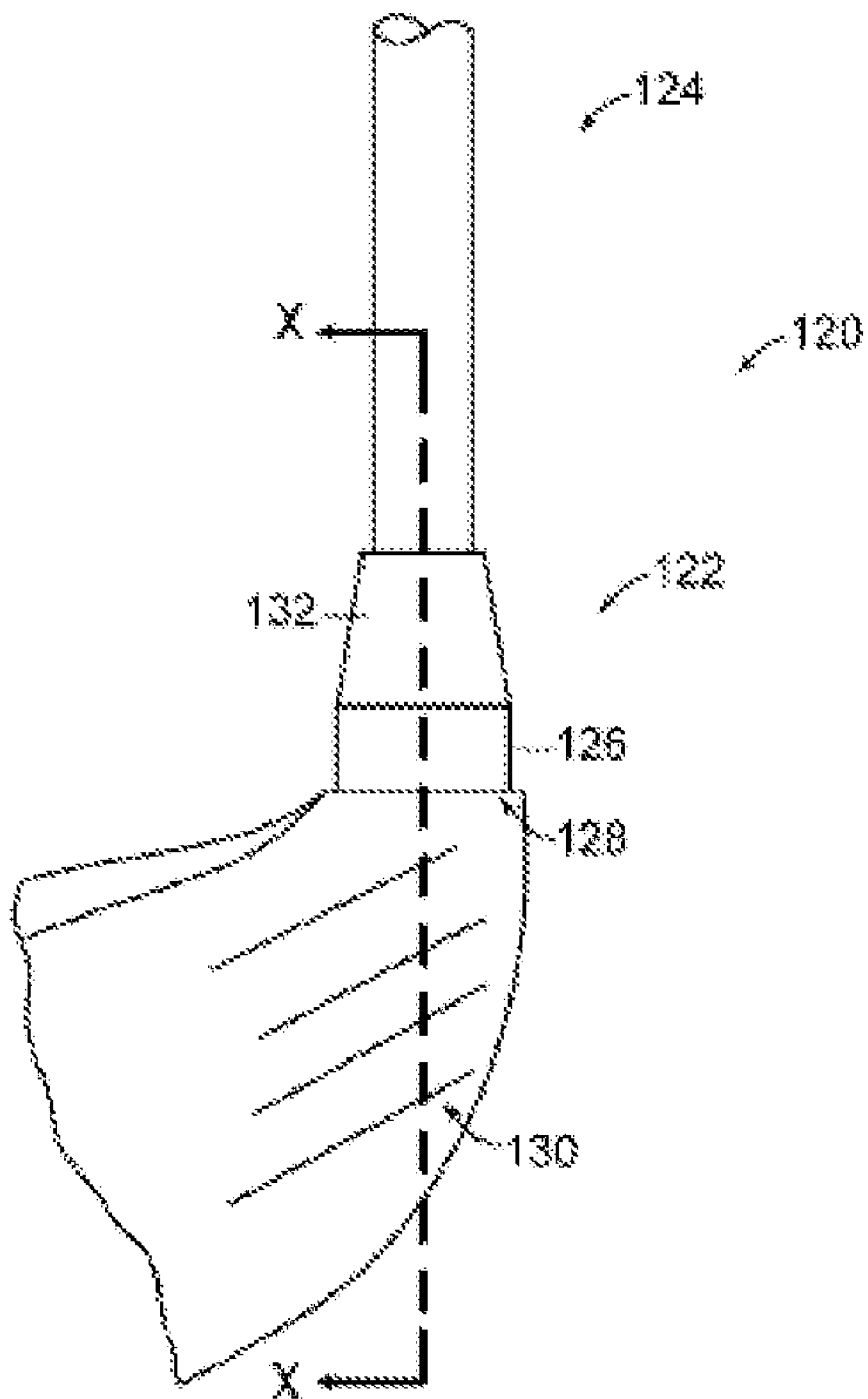
**FIG. 11**



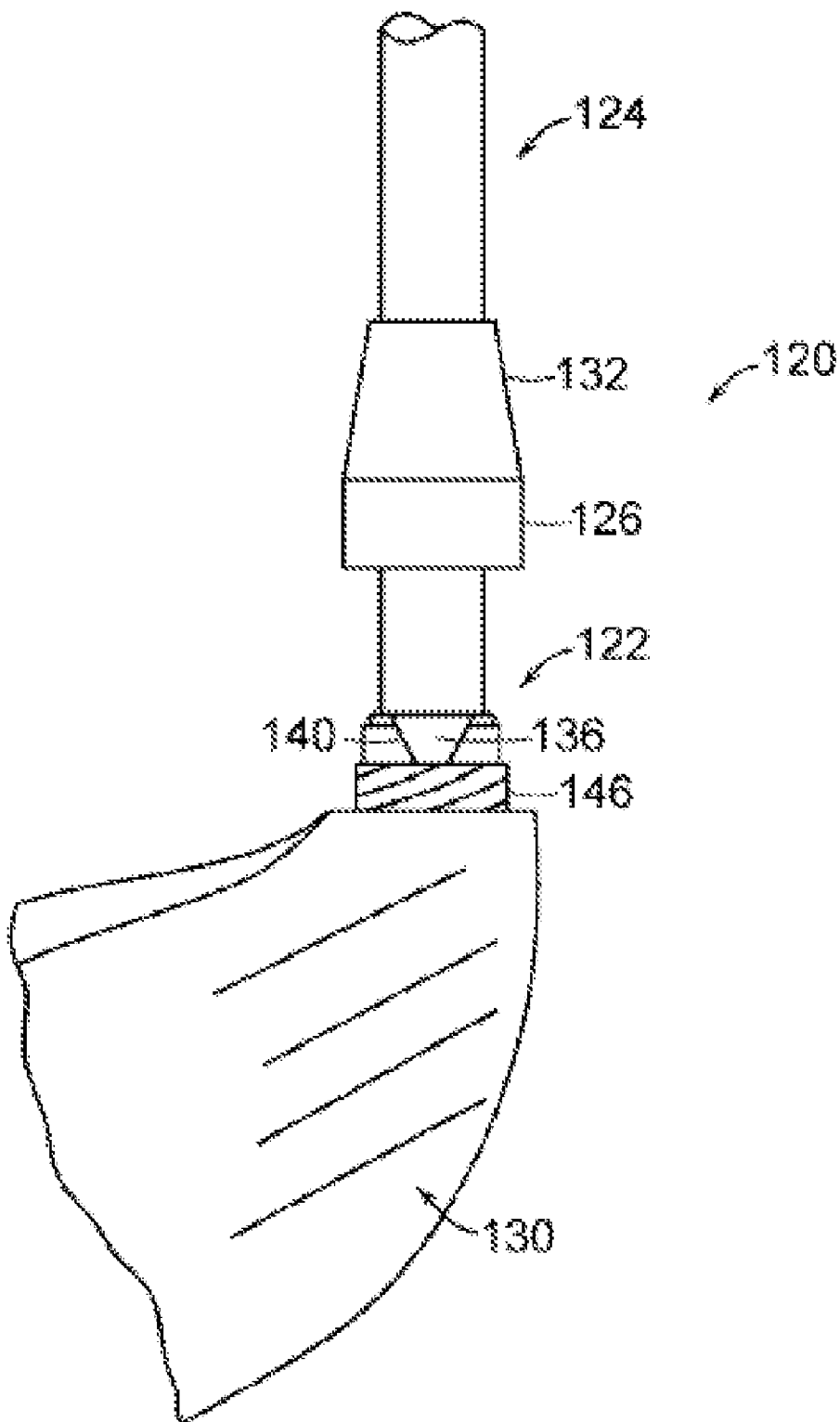
**FIG. 12**



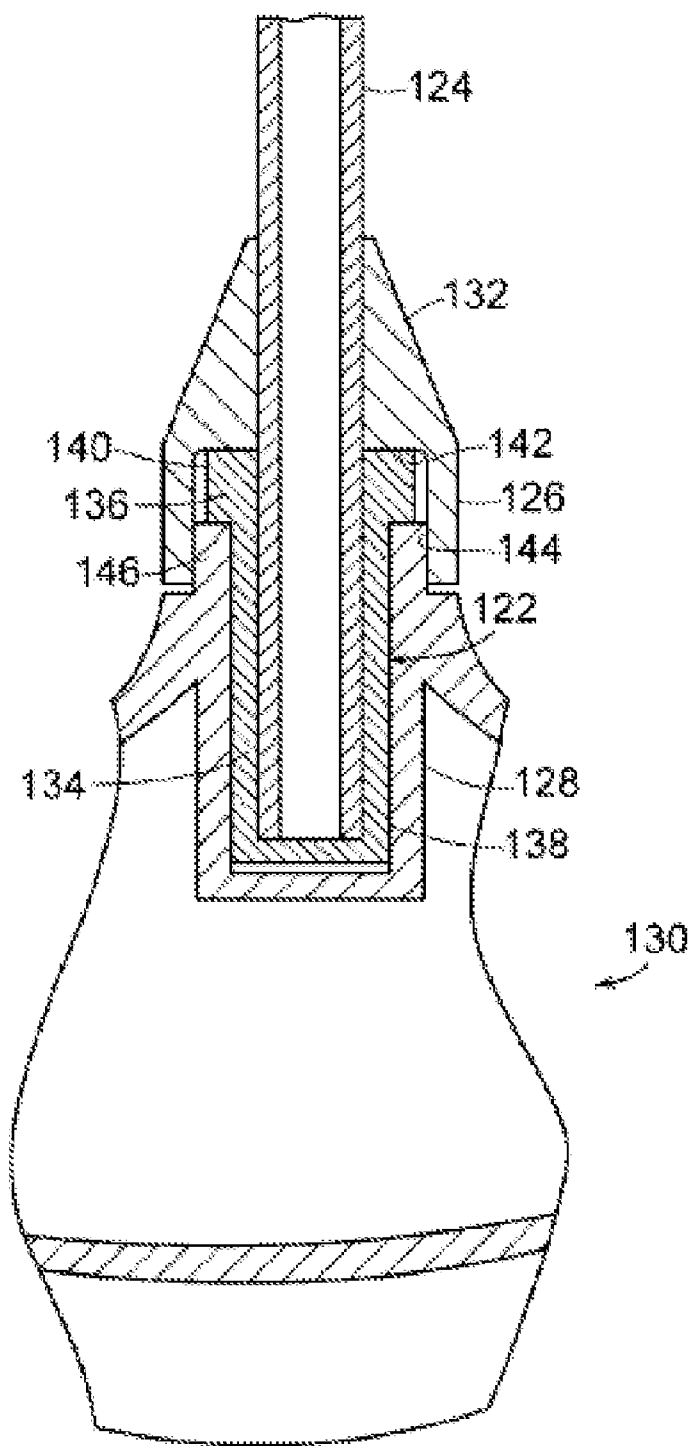
**FIG. 13**



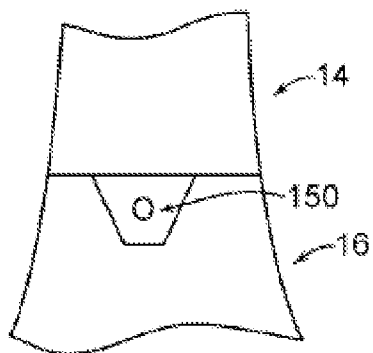
**FIG. 14**



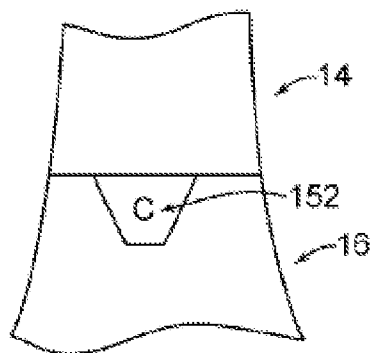
**FIG. 15**



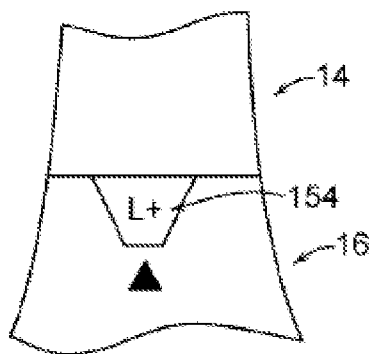
**FIG. 16**



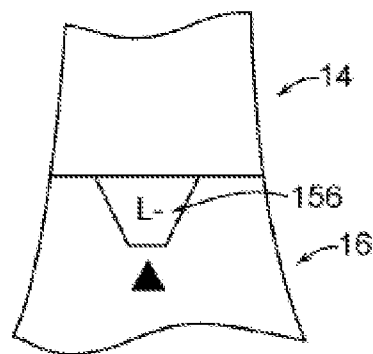
**FIG. 17**



**FIG. 18**



**FIG. 19**



**FIG. 20**

**GOLF CLUB GRIP**

**RELATED APPLICATION**

[0001] The present application claims the benefit of and priority to U.S. provisional application Ser. No. 61/525,358, filed Aug. 19, 2011, the content of which is incorporated by reference herein in its entirety.

**FIELD OF THE INVENTION**

[0002] The invention generally relates to a grip for a golf club.

**BACKGROUND**

[0003] In order to improve their game, golfers often customize their equipment to fit their particular swing. One such customization involves adjusting a position of a club head (e.g., open, closed, or neutral) to accommodate the golfer's particular swing. Such adjustment allows the golfer to compensate for any natural hook or slice that is produced by the golfer's swing. An adjustment of the club head can be easily accomplished with the advent of golf clubs in which the club head position can be manipulated or re-positioned with respect to the club shaft. See for example, Clausen et al. (U.S. Pat. No. 7,621,820) and Morris et al. (U.S. Pat. No. 7,699,717).

[0004] A problem with adjusting the club head in relation to the shaft is that it adjusts the position of the grip. A golf club grip is generally used by a golfer to align their hands on the club as they address the ball. The grip may include a marker or a particular pattern that the golfer utilizes to consistently position their hands each time they hold the club. Such a process allows a golfer to maintain a consistent and repeatable approach to a golf shot. By rotating the grip to accommodate the different club head positions, the golfer experiences a different view of the grip depending on the position of the club head. Changing the view of the grip disrupts the golfer's normal approach to grasping the club and the golfer loses the alignment points that they use to maintain a consistent and repeatable grip.

**SUMMARY**

[0005] The invention generally relates to a golf club grip having a pattern such that a view of the grip is identical to a user for every position of a multi-positional club head of a golf club. In this manner, a golfer is able to use the marker or particular pattern on the grip to consistently position their hands each time they hold the club regardless of the adjustment made to the position of the club head or any rotation of the club shaft. Thus, the golfer is able to maintain a consistent and repeatable approach to a golf shot. Grips of the invention may be used with any golf club and are particularly useful with a driver, fairway wood (e.g., 3-wood, 5-wood, or 7-wood) or hybrid club.

[0006] In certain embodiments, the grip further includes a universal texture such that the texture of the grip is identical to the user regardless of the position of the multi-positional club head. The grip can accommodate any number of club head positions. In certain embodiments, the club head has three different positions (e.g., open, closed, neutral), and the grip produces an identical view to a user in all three positions of the club head.

[0007] Grips of the invention may include any pattern so long as the pattern is such that the view of the grip is identical

to a user for every position of a multi-positional club head of a golf club. In certain embodiments, the pattern includes a plurality of waves. In particular embodiments, a trough of the waves is visible to the user on a top portion of the grip, and a crest of the waves is visible to the user on a bottom portion of the grip.

[0008] Another aspect of the invention provides a golf club grip having an alignment marker such that a view of the marker is identical to a user for every position of a multi-positional club head of a golf club. In certain embodiments, the grip further includes a universal texture such that the texture of the grip is identical to the user regardless of the position of the multi-positional club head.

[0009] Another aspect of the invention provides a golf club grip having a plurality of identical alignment markers, each marker corresponding to a position of a multi-positional club head such that a view of the marker is identical to a user for every position of the multi-positional club head. In certain embodiments, the grip further includes a universal texture such that the texture of the grip is identical to the user regardless of the position of the multi-positional club head.

[0010] Another aspect of the invention provides a golf club including a multi-positional club head, a shaft configured to accommodate the multi-positional club head, and a grip having a pattern such that a view of the grip is identical to a user for every position of the multi-positional club. In certain embodiments, the club is a driver.

[0011] Another aspect of the invention provides a golf club including a multi-positional club head, a shaft configured to accommodate the multi-positional club head, and a grip having an alignment marker such that a view of the marker is identical to a user for every position of the multi-positional club head. In certain embodiments, the club is a driver.

[0012] Another aspect of the invention provides a golf club including a multi-positional club head, a shaft configured to accommodate the multi-positional club head, and a grip having a plurality of identical alignment markers, each marker corresponding to a position of the multi-positional club head such that a view of the marker is identical to a user for every position of the multi-positional club head. In certain embodiments, the club is a driver.

**BRIEF DESCRIPTION OF THE DRAWINGS**

[0013] FIG. 1 is a diagram showing an exploded view of a grip of the invention.

[0014] FIG. 2 is a diagram showing an embodiment of a butt cap of a grip of the invention.

[0015] FIG. 3 is a side view of a portion of an exemplary golf club including an embodiment of the interchangeable shaft system of the present invention.

[0016] FIG. 4 is an exploded view of the golf club of FIG. 3.

[0017] FIG. 5 is a cross-sectional view taken along line Y-Y, shown in FIG. 3, of the golf club.

[0018] FIG. 6 is a perspective view of a shaft sleeve of the interchangeable shaft system.

[0019] FIG. 7 is a perspective view of a proximal end portion of the hosel of the golf club of FIG. 3.

[0020] FIG. 8 is a perspective view of another embodiment of a proximal end portion of a hosel of a golf club having an interchangeable shaft system.

[0021] FIG. 9 is a perspective view of another embodiment of the shaft sleeve of the interchangeable shaft system.



[0022] FIG. 10 is a perspective view of another embodiment of the shaft sleeve of the interchangeable shaft system.

[0023] FIG. 11 is a partial cross-sectional view of another embodiment of the shaft sleeve of the interchangeable shaft system.

[0024] FIG. 12 is an exploded view of a golf club including another embodiment of the interchangeable shaft system of the present invention.

[0025] FIG. 13 is a schematic of the connection between a shaft sleeve and a shaft of the interchangeable shaft system.

[0026] FIG. 14 is side view of a portion of a golf club including another embodiment of the interchangeable shaft system of the present invention.

[0027] FIG. 15 is a partial exploded view of the golf club of FIG. 14.

[0028] FIG. 16 is a cross-sectional view taken along line X-X, shown in FIG. 14, of the golf club.

[0029] FIGS. 17-20 are side views of various indicia that may be incorporated into a golf club including the interchangeable shaft system of the present invention.

#### DETAILED DESCRIPTION

[0030] The invention generally relates to a grip for a golf club. In certain embodiments, the invention provides a golf club grip having a pattern such that a view of the grip is identical to a user for every position of a multi-positional club head of a golf club. FIG. 1 shows an embodiment of grip of the invention. This figure shows an exploded view for a golf club having a club head that may be adjusted to three different positions (1, 2, and 3). The positions of the club head are closed, open, and neutral. A further description of a golf club having an adjustable club head position is shown for example, in Clausen et al. (U.S. Pat. No. 7,621,820) and Morris et al. (U.S. Pat. Nos. 7,699,717 and 7,789,766), the content of each of which is incorporated by reference herein in its entirety.

[0031] The grip includes a pattern 4, that wraps around the entirety of the grip. Such a pattern is an exemplary pattern and grips of the invention may include any pattern so long as the pattern is such that the view of the grip is identical to a user for every position of a multi-positional club head of a golf club. In this figure, the pattern 4 is shown as a plurality of waves 5. The grip is configured such that a trough 6 of the waves 5 is visible to the user on a top portion of the grip 7, and a crest 8 of the waves 5 is visible to the user on a bottom portion 9 of the grip.

[0032] Based upon adjustment of the club head in relation to the shaft, the user is always presented the same view of the grip as described above. Specifically, in the open position, the user is presented with a view of the grip in which the pattern 4 is shown as a plurality of waves 5 in which a trough 6 of the waves 5 is visible to the user on a top portion 7 of the grip, and a crest 8 of the waves 5 is visible to the user on a bottom portion 9 of the grip. In the closed position, the user is presented with a view of the grip in which the pattern 4 is shown as a plurality of waves 5 in which a trough 6 of the waves 5 is visible to the user on a top portion 7 of the grip, and a crest 8 of the waves 5 is visible to the user on a bottom portion 9 of the grip. In the neutral position, the user is presented with a view of the grip in which the pattern 4 is shown as a plurality of waves 5 in which a trough 6 of the waves 5 is visible to the user on a top portion 7 of the grip, and a crest 8 of the waves 5 is visible to the user on a bottom portion 9 of the grip.

[0033] In this manner, a golfer is able to use the marker or particular pattern on the grip to consistently position their hands each time they hold the club regardless of the adjust-

ment made to the position of the club head or any rotation of the club shaft. Thus, the golfer is able to maintain a consistent and repeatable approach to a golf shot.

[0034] The butt cap of the grip has no pattern or a pattern such that the view of the butt cap is identical to the user for every position of the multi-positional club head of the golf club (FIG. 2). Grips of the invention may be used with any golf club and are particularly useful with a driver.

[0035] In other embodiments, the grip includes at least one alignment marker. The markers are positioned on the grip to correspond with the positions of the club head. For example, a multi-positional golf club having three club head positions (e.g., closed, open, and neutral) would have a grip having three identical markers, each marker being aligned with a position of the club head for the multi-positional golf club. In this manner, a view of the marker is identical to a user for every position of a multi-positional club head of a golf club. The marker may be any type of identifier that denotes a position on a golf club to a user. Exemplary markers include symbols (e.g., +, -, l, °, etc.), a color identifier, a differentiated pattern, and the like.

#### Multi-Positional Golf Club Head

[0036] Grips of the invention are particularly useful with golf clubs in which the position of the club head can be adjusted relative to the shaft. Morris (U.S. Pat. No. 7,789,766, the content of which is incorporated by reference herein) shows an interchangeable shaft system for connecting the shaft of a golf club to a club head. Such a system can be utilized to provide for customized fitting of various shaft types to a club head and/or to provide adjustability between a shaft and a club head. Several embodiments of the present invention are described below.

[0037] A golf club incorporating an interchangeable shaft system 10 generally includes a shaft 12, a shaft sleeve 14, a club head 16 and a fastener 18. Interchangeable shaft system 10 may be used by club fitters to repeatedly change shaft 12 and club head 16 combinations during a fitting session. The system permits fitting accounts maximum fitting options with an assembly of parts that is easy to use. In an embodiment, after a desired shaft 12 and club head 16 combination is selected, interchangeable shaft system 10 may be semi-permanently fixed so that disassembly by the average consumer is prevented. Alternatively, interchangeable shaft system 10 may be configured so that a consumer may manipulate the connection to replace shaft 12 or club head 16 and/or to provide adjustability between shaft 12 and club head 16.

[0038] As illustrated, the interchangeable shaft system of the present invention is incorporated into a driver style golf club. However it should be appreciated that the interchangeable shaft system of the present invention may be incorporated into any style of golf club. For example, the interchangeable shaft system may be incorporated into putters, wedges, irons, hybrids and/or fairway wood styles of golf clubs.

[0039] Club head 16 generally includes a face 24, a crown 25, a sole 26 and a skirt 27 that are combined to form the generally hollow club head 16. Club head 16 also includes hosel 20 that is a structure providing for a secure attachment between shaft 12 and club head 16 during manufacture of the golf club.

[0040] Shaft 12 may be any shaft known in the art. For example, shaft 12 may be constructed of metallic and/or non-metallic materials and shaft may be hollow, solid or a combination of solid and hollow portions.

[0041] Referring to FIGS. 3-7, interchangeable shaft system 10 connects shaft 12 to club head 16 so that different shafts 12 can be selectively connected to different club heads 16.

[0042] Interchangeable shaft system 10 generally includes shaft sleeve 14 that is coupled to shaft 12 and at least partially received within hosel 20 of club head 16 and fastener 18 that releasably couples sleeve 14 to club head 16.

[0043] In the assembled interchangeable shaft system 10, a distal end portion 34 of shaft 12 is received within a shaft bore 36 of sleeve 14 and is securely attached thereto. Shaft 12 may be securely attached to sleeve 14 using any fastening method. For example, attachment methods such as welding, ultrasonic welding, brazing, soldering, bonding, etc., may be employed. Adhesives such as epoxies or other similar materials may be utilized to securely fasten shaft 12 and sleeve 14. Preferably, end portion 34 is bonded within shaft bore 36 using an adhesive, such as epoxy.

[0044] Sleeve 14 is inserted into hosel 20 in a selected orientation that assures that alignment features included on sleeve 14 and hosel 20 are engaged when the interchangeable shaft system is assembled. The orientation of the alignment features provides a desired relative position between shaft 12 and club head 16. Additionally, the engagement of the alignment features provides an anti-rotation feature that prevents relative rotation between sleeve 14 and hosel 20 about the longitudinal axis of hosel 20.

[0045] Hosel 20 is a generally tubular member that extends through crown 25 and at least a portion of club head 16. Hosel 20 defines a sleeve bore 30 that has a diameter selected so that a distal portion of sleeve 14 may be slidably received therein. Preferably, the diameter of sleeve bore 30 is selected so that there is minimal clearance between distal portion of sleeve 14 and hosel 20 to prevent relative lateral motion between sleeve 14 and hosel 20. Sleeve bore 30 terminates at a distal flange 31, which is located at a distal end of hosel 20. It should be appreciated, however, that the flange may be located at any intermediate position between the proximal and distal ends of the hosel.

[0046] In the present embodiment, a proximal end 28 of hosel 20 is disposed outward from club head 16 at a location spaced from crown 25 and includes at least one hosel alignment feature that extends through at least a portion of the sidewall of hosel 20. The hosel alignment feature provides at least one discrete alignment orientation between club head 16 and shaft 12 in the assembled golf club. In the present embodiment, hosel 20 includes alignment features in the form of a pair of notches 32 and each notch 32 extends through the sidewall of hosel 20 adjacent proximal end 28, i.e., each notch 32 extends from sleeve bore 30 to the outer surface of proximal end 28 of hosel 20.

[0047] It should be appreciated that the hosel alignment feature need not extend entirely through the sidewall of the hosel and may extend through only a portion of the sidewall, as shown in the embodiment illustrated in FIG. 8. In particular, a proximal end portion 22 of a hosel 21 may include notches 33 that extend only through a portion of the sidewall of hosel 21. For example, notches 33 of the present embodiment include a generally trapezoidal cross-section similar to the previously described embodiment, however, notches 33 extend radially from sleeve bore 29 through a portion of the sidewall of proximal portion 22 of hosel 21 and do not inter-

sect the outer surface of hosel 21. Such an embodiment may be preferred when it is desired to hide the alignment features from a user.

[0048] Notches 32 are diametrically opposed from each other in proximal end 28 at spaced locations about the proximal end of the generally tubular hosel 20. That configuration allows the combined shaft 12 and sleeve 14 to be coupled to club head 16 in two discrete positions rotated approximately 180° from each other. However, the hosel alignment features may be located in any desired position adjacent proximal end 28 of hosel 20 to provide any desired orientation between sleeve 14 and hosel 20. Although the present invention includes a pair of hosel alignment features, any number of hosel alignment features may be provided to provide any number of discrete orientations between shaft 12 and club head 16. Still further, a single hosel alignment feature may be provided when a single discrete orientation between the shaft and club head is desired.

[0049] Sleeve 14 includes a distal body 38, a proximal ferrule 40 and at least one sleeve alignment feature. The present embodiment includes a pair of sleeve alignment features (e.g., tangs 42). Body 38 is generally cylindrical and includes a proximal end that is coupled to a distal end of ferrule 40. The length of shaft sleeve 14 and the diameter of shaft 12 may be selected so that adequate surface area is provided for attachment to shaft 12. Shaft sleeve 14 and shaft 12 are configured to provide approximately 0.5-2.0 in<sup>2</sup> of bonding surface area. In an embodiment, shaft sleeve 14 and shaft are selected to provide approximately 1.2 in<sup>2</sup> of bonding surface area. In particular, in that embodiment, shaft sleeve 14 has a bonding length of approximately 1.1 inches to provide adequate bonding surface area on a shaft having a 0.335 inch diameter. In the present embodiment, body 38 and ferrule 40 are coupled so that they form a single integrated component, but it should be appreciated that body 38 and ferrule 40 may be separate components.

[0050] Tangs 42 extend laterally outward beyond an outer surface of body 38 adjacent the interface between body 38 and ferrule 40. The shape of tangs 42 is selected to complement the shape of notches 32 so that relative rotation about the longitudinal axis of hosel 20 in either direction between sleeve 14 and hosel 20 is prevented when tangs 42 engage notches 32. For example, tangs 42 have a generally trapezoidal cross-sectional shape and that trapezoidal shape is selected to complement and engage the trapezoidal shape of notches 32. Tangs 42 are configured so that they are tapered with the narrowest portion oriented toward the distal end of sleeve 14 and notches 32 are similarly tapered with the narrowest portion oriented toward sole 26 of club head 16. Additionally, the outer surfaces of tangs 42 are curved with a diameter that is substantially identical to the outer diameter of proximal end 28 of hosel 20 so that the outer surface of tangs 42 are substantially flush with the outer surface of hosel 20 in an assembled golf club. However, it should be appreciated that the outer surface of the tangs and the proximal end of the hosel need not be flush if desired.

[0051] The complementary shapes of notches 32 and tangs 42 assure that there is a secure fit between sleeve 14 and hosel 20 when interchangeable shaft system 10 is assembled. In particular, as sleeve 14 is inserted into sleeve bore 30 of hosel 20, the tapered side edges of tangs 42 forcibly abut the tapered side walls of notches 32 to provide a secure fit that assures consistent and repeatable positioning of sleeve 14 relative to hosel 20. The tapered surfaces also prevent rotational play

between sleeve 14 and hosel 20 resulting from manufacturing tolerances or wear. Alternatively, the hosel and sleeve alignment features may have curved edges and side walls that engage during assembly to provide a similarly secure fit.

[0052] In the present embodiment, the outer diameter of body 38 is smaller than the outer diameter of the distal end of ferrule 40 so that a shoulder 46 is created at the interface between body 38 and ferrule 40. During assembly, body portion 38 of sleeve is inserted into sleeve bore 30 until shoulder 46 is disposed adjacent the top edge of hosel 20. The size, taper and/or curvature of the hosel and sleeve alignment features (e.g., tangs 42 and notches 32) are preferably selected so that there is a small amount of clearance between shoulder 46 and hosel 20 when the golf club is assembled. Additionally, with respect to the present embodiment, the size and taper of tangs 42 and notches 32 are selected so that there is a small amount of clearance between the distal end surfaces of tangs 42 and the distal end surfaces of notches 32. That clearance allows the relative position between sleeve 14 and hosel 20 to be easily controlled by manipulating the dimensions of the respective alignment features. Preferably, the amount of clearance between shoulder 46 and hosel 20 is visually imperceptible, or at least not easily noticeable, in the assembled golf club. For example, the amount of clearance may range from 0.005-0.030 inches.

[0053] Sleeve 14 and hosel 20 may be constructed from any metallic or non-metallic material, such as, for example, titanium, steel, aluminum, nylon, fiber reinforced polymer or polycarbonate. Furthermore, sleeve 14 and hosel 20 may be constructed from the same or different materials and as discussed further below each of sleeve 14 and hosel 20 may alternatively have multi-material construction. Additionally, sleeve 14 and/or hosel 20 may be constructed from a material that is a combination of both metallic and non-metallic material, such as a polymer infused or plated with metallic material. In an embodiment, hosel 20 is constructed of titanium and sleeve 14 is constructed from aluminum. Preferably, hosel 20 is formed as an integral part of club head 16.

[0054] A coating or surface treatment may also be provided on sleeve 14 and/or hosel 20 to prevent corrosion and/or to provide a desired aesthetic appearance. For example, in embodiments utilizing sleeve 14 constructed from a first metallic material, such as aluminum, and hosel 20 constructed from a second metallic material, such as titanium, sleeve 14 may be anodized to prevent galvanic corrosion. As a further example, a non-metallic sleeve 14 may be coated with nickel to provide the appearance of metallic construction.

[0055] Sleeve 14 is securely fastened to club head 16 by fastener 18 to prevent disengagement of sleeve 14 from sleeve bore 30. Fastener 18 is primarily employed to prevent relative motion between sleeve 14 and club head 16 in a direction parallel to the longitudinal axis of hosel 20. Fastener 18 may be any type of fastener that restricts relative motion between sleeve 14 and hosel 20. For example, and as shown in the present embodiment, fastener 18 is an elongate mechanical fastener, such as a machine screw that engages a threaded hole in sleeve 14. Fastener 18 and sleeve 14 are dimensioned to provide sufficient thread length to withstand the axial forces placed upon interchangeable shaft system 10. In one exemplary embodiment, fastener 18 and sleeve 14 are dimensioned to provide ¼ inch of threaded engagement. Additionally, thread inserts may be provided if desired to increase the strength of the threads. For example, a thread insert such as

Heli-coil thread inserts (a registered trademark of Emhart, Inc. of Newark, Del.) may be installed into sleeve 14.

[0056] As shown in FIG. 5, hosel 20 extends only partially through club head 16. A separate fastener bore 50 is provided that extends into club head 16 proximally from sole 26 and is generally coaxially aligned with hosel 20. The proximal end of fastener bore 50 terminates at a proximal flange 54. Flange 54 is generally annular and provides a bearing surface for a head portion of fastener 18. A shank of fastener 18 extends through flange 54, across a gap 52 between fastener bore 50 and hosel 20, through flange 31 and engages flange 44 of sleeve 14.

[0057] During assembly, as fastener 18 is tightened, sleeve 14 is drawn into hosel 20. Simultaneously, tangs 42 of sleeve 14 are drawn into notches 32 of hosel 20 and the tapered side edges of tangs 42 forcibly abut the tapered side walls of notches 32. The tapered interface between tangs 42 and notches 32 assures that as fastener 18 is tightened in sleeve 14, the fit between sleeve 14 and hosel 20 becomes progressively more secure and sleeve 14 travels to a predetermined and repeatable position within hosel 20.

[0058] The depth of hosel 20 and sleeve bore 30 in club head 16 may be selected so that a desired length of shaft 12 and sleeve 14 are received therein. In the present embodiment, hosel 20 extends only partially into club head 16. It should, however, be appreciated that the hosel may extend through the entire club head so that it intersects the sole. In such embodiments, a flange providing a bearing surface for the head of the fastener may be located at any intermediate location within the hosel and a separate fastener bore need not be provided.

[0059] As previously described, the hosel alignment features are located adjacent proximal end 28 of hosel 20 and extend through at least a portion of the side wall of hosel 20. Locating the hosel alignment features adjacent proximal end 28 of hosel 20 greatly simplifies manufacture of the hosel alignment features and club head 16 because the area is easily accessible. In particular, alignment features having precise tolerances may be incorporated into hosel 20 by simple machining processes and using common tools. For example, a generally trapezoidal hosel alignment feature extending entirely through the sidewall of hosel 20, such as notch 32, may be machined using a tapered end mill that is passed diametrically across proximal end 28 of a cast club head 16. As a result of that location, hosel alignment features having tightly controlled dimensions may be easily constructed with any desired shape by using simple tooling and processes.

[0060] The alignment features may be positioned at any location around the circumference of sleeve 14 and hosel 20. Preferably, a pair of alignment features are disposed approximately 180° apart about the circumference of body 38 and hosel 20 (i.e., the alignment features are diametrically opposed) with one of the features being located adjacent face 24 of club head 16. That orientation results in the alignment features being obscured from sight when a user places the club in the address position and views the club along a line of sight that is generally parallel to the longitudinal axis of shaft 12. That orientation also allows the alignment features to be easily viewed by a user during adjustment by viewing club head 16 along a line of sight that is generally normal to face 24.

[0061] As an additional feature, a locking mechanism may be provided to prevent fastener 18 from disengaging from sleeve 14. Any locking mechanism may be employed. For

example, lock washers may be provided between the head of fastener **18** and the adjacent bearing surface. As a further alternative, a locking thread design, such as a Spiralock locking internal thread form (a registered trademark of Detroit Tool Industries Corp. of Madison Heights, Mich.) may be incorporated into threaded bore **48** of flange **44**. As a still further alternative, a thread locking material, such as Loctite thread locking adhesive (a registered trademark of the Henkel Corp. of Gulph Mills, Pa.) may be applied to fastener **18** or threaded bore **48**. Still further, fastener **18** may be provided with a locking feature such as a patch lock. Additionally, a bonding material, such as epoxy may be applied to the head of fastener **18** at an interface with club head **16** after assembly.

**[0062]** As a still further feature, a retainer **56** may be employed so that fastener **18** is retained within club head **16** when it is not engaged with sleeve **14**. During replacement of shaft **12** it is desired that fastener **18** is retained within club head **16** so that it is not misplaced. Retainer **56** is coupled to the shank of fastener **18** and located so that a flange is interposed between retainer **56** and the head of fastener **18**. Retainer **56** is sized so that it is not able to pass through the through hole of the respective flange. Retainer **56** may be a clip that is frictionally coupled to the shank of fastener **18** adjacent flange **31** of hosel **20** located so that flange **31** is interposed between retainer **56** and the head of fastener **18**.

**[0063]** Referring to FIGS. **9** and **10** embodiments of a multi-piece shaft sleeve will be described that may be substituted for shaft sleeve **14** in the previously described interchangeable shaft system. The multi-piece embodiments provide a configuration that allows for the use of alternative machining processes as compared to a single piece, machined or molded shaft sleeve. Additionally, it provides additional options for including multiple materials in a single shaft sleeve which may provide weight and/or manufacturing advantages. In an embodiment, shaft sleeve **63** includes a multi-piece construction that includes a body **65**, a pair of alignment features (e.g., tangs **67**) and a ferrule **69**. In the present embodiment, tangs **67** are integral with ferrule **69**, but body **65** is a separate component.

**[0064]** Body **65** is generally cylindrical and includes a proximal end that is located adjacent a distal end of ferrule **69** when assembled on a shaft. The proximal end of body **65** includes notches **71** that are sized and shaped to complement the size and shape of tangs **67**. In particular, notches **71** are preferably sized and shaped so that there are no gaps between the distal surface of ferrule **69** and the proximal end surface of body **65** or between the side surfaces of tangs **67** and the side surfaces of notches **71**. Additionally, the thickness of tangs **67** is selected so that when shaft sleeve **63** is assembled, portions of tangs **67** extend radially outward beyond the outer surface of body **65**. As a result, that portion of tangs **67** extending radially outward from body **65** is available to engage engagement features provided in the proximal end portion of the hosel of a golf club head as described above.

**[0065]** Referring to FIG. **10**, another alternative embodiment of the shaft sleeve will be described. Shaft sleeve **64** includes a body **66**, a pair of alignment features (e.g., tangs **68**) and a ferrule **70**. Tangs **68** are integral with body **66** and ferrule **70** is separate from tangs **68** and body **66**. Body **66** is generally cylindrical and includes a proximal end that is located adjacent a distal end of ferrule **70** when assembled on a shaft. Tangs **68** extend laterally outward from body **66** adjacent the proximal end of body **66**.

**[0066]** Body **66** and ferrule **70** may be constructed from any materials and they may be constructed from the same or different materials. For example, body **66** may be machined from a metallic material, such as aluminum, and ferrule **70** may be molded or machined from a non-metallic material, such as nylon. Different materials may be used to provide weight savings over an entirely metallic sleeve while still providing adequate structural qualities and bonding surface area. Additionally, different materials may be selected to provide desired aesthetic properties.

**[0067]** The body of any embodiment of the shaft sleeve may further include weight reducing features if desired. For example, and as shown in FIG. **10**, shaded portion **72** may include slots, depressions, through holes or any other feature that reduces the volume of material from which body **66** is constructed. The volume of body material may be reduced over any desired portion of the shaft sleeve body as long as sufficient surface area is provided for adequately coupling the shaft with the shaft sleeve.

**[0068]** A further embodiment of the shaft sleeve is illustrated in FIG. **11**. Similar to the previously described embodiments, shaft sleeve **74** includes a body **76**, a ferrule **78** and tangs **80** extending laterally outward from body **76**. Shaft sleeve **74** is illustrative of a single piece construction of the shaft sleeve that is molded from a non-metallic material, such as, for example, nylon, fiber reinforced polymer or polycarbonate. Because of that construction, shaft sleeve **74** also includes a threaded insert **82** that is molded into a distal flange **84** of sleeve **74**. Threaded insert **82** may include features that allow the insert to be securely molded in place, such as knurling and/or one or more ribs or flanges.

**[0069]** A still further embodiment of the shaft sleeve is shown in FIG. **12**, which illustrates an exploded view of a portion of another embodiment of a golf club including an interchangeable shaft system. Similar to the previously described embodiments, the golf club includes a shaft **90** that is coupled to a hosel **92** of a club head by an interchangeable shaft system that includes a shaft sleeve **94**.

**[0070]** In the present embodiment, sleeve **94** utilizes a multi-piece construction. Sleeve **94** includes body **96** that is integral with ferrule **98** and sleeve alignment features that are formed by a separate pin **100** that is coupled to body **96** and ferrule **98**. Pin **100** extends diametrically across the interface of body **96** and ferrule **98** and is securely coupled to body **96** and ferrule **98**. The length of pin **100** is selected so that the ends of pin **100** extend laterally outward beyond the outer surface of body **96**. Preferably, each end of pin **100** extends laterally outward of body **96** by a distance corresponding to the thickness of the side wall of hosel **92** of the club head so that the ends of pin **100** are generally flush with the outer surface of hosel **92**. Although pin **100** is illustrated as a generally cylindrical member, it should be appreciated that it may have any desired cross-sectional shape and hosel **92** may include hosel alignment features having any complementary shape. For example, pin **100** may be a key having any polygonal cross-sectional shape, such as a triangle, trapezoid, square, rectangle, diamond, etc.

**[0071]** The interchangeable shaft system of the present invention may be configured to provide adjustability for the angular attributes of an assembled golf club, including face angle, lie and loft. As described above, the configuration of the hosel and sleeve alignment features provide discreet orientations of the sleeve relative to the hosel. The shaft may be mounted to the sleeve so that the shaft is not coaxial with the

sleeve. That misalignment allows each of the discreet orientations of the sleeve relative to the hosel to correspond to a different orientation of the shaft to the club head. For example, by mounting the shaft to the sleeve so that the longitudinal axis of the shaft is rotated relative to the shaft, the angular attributes of the assembled golf club may be adjustable by changing the orientation of the shaft sleeve relative to the hosel.

[0072] As shown in FIG. 13, a shaft 102 is mounted to a sleeve 104 so that an angular attribute, or select combinations of angular attributes, may be adjusted between at least a first configuration and a second configuration. In particular, a longitudinal axis A of a shaft bore 106 of sleeve 104 may be rotated relative to a longitudinal axis B of a body 108 and a ferrule 110 of sleeve 104. As a result, when a shaft 102 is inserted into sleeve bore 106, the longitudinal axis of shaft 102 is coaxial with longitudinal axis A of sleeve bore 106. By rotating sleeve 104 approximately 180°, the orientation of shaft 102 relative to sleeve 104 changes from a positive to a negative angle relative to longitudinal axis B.

[0073] The direction of the rotational offset between axis A and axis B is positioned relative to the hosel and sleeve alignment features so that rotation of the sleeve within the hosel between the two positions alters the club face angle. In particular, the sleeve may be coupled to the hosel in a first position corresponding to a first configuration wherein the club face is opened. The sleeve may then be coupled to the hosel in a second position, e.g., the sleeve is rotated 180° from the first position, which corresponds to a second configuration wherein the club face is closed. It should be appreciated that shaft 102 and sleeve 104 may be coupled so that more than two configurations are provided. For example, the sleeve and accompanying golf club head may be configured so that there are more than two relative configurations thereby providing adjustability in multiple combinations of angular attributes.

[0074] Additionally, the depth of the hosel alignment features may be different and, as a result, a golf club including the interchangeable shaft system of the present invention may be adjustable for overall length by providing a plurality of hosel alignment features having different depths. For example, in an embodiment, a pair of hosel alignment features having different depths from the proximal end of the hosel are provided in a golf club head. A shaft sleeve is provided that includes a single sleeve alignment feature that is sized and shaped to engage either of the hosel alignment features. In a first configuration, the sleeve alignment feature is engaged with the deeper hosel alignment feature, which results in the sleeve being drawn into the hosel to a first depth and thereby providing a first overall golf club length. In a second configuration, the sleeve alignment feature is engaged with the shallower hosel alignment feature, which results in the sleeve being drawn into the hosel to a second depth that is less than the first depth and thereby providing a second overall golf club length that is less than the first.

[0075] Referring to FIGS. 14-16, another embodiment of the interchangeable shaft system of the present invention will be described. Interchangeable shaft system 120 is similar to the previously described embodiments in that it generally includes a shaft sleeve 122 that is coupled to a shaft 124 and a fastener 126 that retains sleeve 122 within a hosel 128 of a club head 130. In the present embodiment, however, fastener 126 is integral with a ferrule 132.

[0076] Sleeve 122 includes a body 134 and alignment features (e.g., tangs 136). Sleeve 122 includes a separate ferrule 132. In the assembled golf club, body 134 of sleeve 122 is at least partially received within a sleeve bore 138 of hosel 128. Body 134 is oriented so that tangs 136 engage complementary alignment features of hosel 128 (e.g., notches 140).

[0077] Fastener 126 is integrated into and forms a portion of ferrule 132. In particular, fastener 126 is a distal portion of ferrule 132 that is configured to mechanically engage a portion of hosel 128. For example, fastener 126 is a portion of ferrule 132 that includes a threaded internal 144 surface and is configured to threadably engage a threaded outer surface 146 of hosel 128.

[0078] Ferrule 132 also includes a bearing surface 142. Bearing surface 142 forcibly abuts a proximal end surface of sleeve 122 when interchangeable shaft system 120 is assembled. During assembly, shaft 124 is inserted through ferrule 132 so that ferrule 132 is able to slide on and rotate relative to shaft 124. Next, sleeve 122 is coupled to the distal end of shaft 124. The dimensions of sleeve 122 are selected so that ferrule 132 is prevented from sliding past sleeve 122 toward the distal end of shaft 124. Sleeve 122 is then inserted into sleeve bore 138 so that tangs 136 engage notches 140 with sleeve 122 in a desired rotational orientation. Finally, ferrule 132 is slid along shaft 124 until bearing surface 142 abuts sleeve 122 and fastener 126 is threaded on hosel 128.

[0079] Indicia may be provided to clearly indicate the configuration of the shaft relative to the club head in the assembled golf club. For example, and as described above, the shaft may be coupled to the shaft sleeve so that the club can be assembled in a first or second configuration. Indicia may be placed on the shaft sleeve and/or the hosel to indicate the assembled configuration. The indicia may be positioned so that they are visible only during assembly or during and after assembly, as desired.

[0080] Referring to FIGS. 17-20, any form of indicia may be provided. The indicia may be engraved, raised or painted and they may be one or more letters, numbers, symbols, dots and/or other markings that differentiate the available configurations of the golf club. The indicia may be included on any portion of the club head, shaft sleeve, or shaft of the assembled golf club. Preferably, indicia are provided on or adjacent the sleeve and/or hosel alignment features.

[0081] As shown in FIGS. 3, 17 and 18, the indicia may include letters corresponding to the configuration of the golf club. In an embodiment, indicium 150 is an "O" that is located on a sleeve alignment feature and corresponds to an opened face angle configuration of the golf club. Additionally, indicium 152, in the form of a letter "C," is provided on another sleeve alignment feature that corresponds to a closed face angle club configuration.

[0082] As shown in FIG. 1, the hosel and shaft sleeve alignment features (e.g., notches 32 and tangs 42) and/or indicia are positioned to reduce the visibility of those features during use. In particular, in the assembled golf club, tangs 42 are located so that they are diametrically opposed from each other about the circumference of hosel 20 on an axis that is generally normal to a plane defined by face 24 of club head 16. As a result, tangs 42 are visible along a line of sight generally normal to face 24 of club head 16. However, when a user holds the club in the address position, the tangs 42 are obscured from view, i.e., the alignment features are not visible along an axis generally parallel to the longitudinal axis of

the shaft, and the golf club has an appearance of a golf club lacking the interchangeable shaft system when the golf club head is at address.

[0083] Additional examples of indicia are illustrated in FIGS. 19 and 20. In FIG. 19 indicia 154 and 156 include both letters and symbols (e.g., “L+” and “L-”). Combinations of letters, symbols and/or numbers may be used to clearly indicate the configuration of the assembled golf club. In the present example, indicia 154 and 156 are particularly well-suited to indicate increased and reduced lie or loft angle of the club head, respectively. Additionally, indicium 158 may be provided to indicate to the user which of the indicia included on sleeve 14 corresponds to the assembled configuration of the golf club.

[0084] The interchangeable shaft system of the present invention provides advantages over conventional methods of club fitting. In a conventional fitting session a user is required to make test swings with a plurality of non-adjustable samples of a single golf club. For example, a conventional fitting cart, or bag, generally includes a plurality of sample 6-Irons having multiple configurations. The user is required to try many of those sample clubs to try to determine which sample includes the most appropriate configuration. However, because each sample club is not adjustable, differences between the individual components of the plurality of sample clubs introduce additional variables into the fitting process and the fitting cart, or bag, is required to include many separate and complete sample clubs.

[0085] The embodiments of the present invention are illustrated with driver-type clubs. However, it should be understood that any type of golf club can utilize the inventive interchangeable shaft system.

#### INCORPORATION BY REFERENCE

[0086] References and citations to other documents, such as patents, patent applications, patent publications, journals, books, papers, web contents, have been made throughout this disclosure. All such documents are hereby incorporated herein by reference in their entirety for all purposes.

#### EQUIVALENTS

[0087] The invention may be embodied in other specific forms without departing from the spirit or essential characteristics thereof. The foregoing embodiments are therefore to be considered in all respects illustrative rather than limiting on the invention described herein.

What is claimed is:

1. A golf club grip comprising a pattern such that a view of the grip is identical to a user for every position of a multi-positional club head of a golf club.

2. The grip according to claim 1, further comprising a universal texture such that the texture of the grip is identical to the user regardless of the position of the multi-positional club head.

3. The grip according to claim 1, wherein the club head comprises three positions.

4. The grip according to claim 3, wherein the positions are open, closed, and neutral.

5. The grip according to claim 1, wherein the pattern comprises a plurality of waves.

6. The grip according to claim 5, wherein a trough of the waves is visible to the user on a top portion of the grip.

7. The grip according to claim 6, wherein a crest of the waves is visible to the user on a bottom portion of the grip.

8. The grip according to claim 1, wherein the grip is for a driver.

9. A golf club grip comprising an alignment marker such that a view of the marker is identical to a user for every position of a multi-positional club head of a golf club.

10. The grip according to claim 9, further comprising a universal texture such that the texture of the grip is identical to the user regardless of the position of the multi-positional club head.

11. The grip according to claim 9, wherein the club head comprises three positions.

12. The grip according to claim 11, wherein the positions are open, closed, and neutral.

13. The grip according to claim 9, wherein the marker comprises a plurality of waves.

14. The grip according to claim 13, wherein a trough of the waves is visible to the user on a top portion of the grip.

15. The grip according to claim 14, wherein a crest of the waves is visible to the user on a bottom portion of the grip.

16. The grip according to claim 9, wherein the grip is for a driver.

17. A golf club grip comprising a plurality of identical alignment markers, each marker corresponding to a position of a multi-positional club head such that a view of the marker is identical to a user for every position of the multi-positional club head.

18. The grip according to claim 17, further comprising a universal texture such that the texture of the grip is identical to the user regardless of the position of the multi-positional club head.

19. The grip according to claim 17, wherein the club head comprises three positions.

20. The grip according to claim 19, wherein the positions are open, closed, and neutral.

21. The grip according to claim 17, wherein the marker comprises a plurality of waves.

22. The grip according to claim 21, wherein a trough of the waves is visible to the user on a top portion of the grip.

23. The grip according to claim 22, wherein a crest of the waves is visible to the user on a bottom portion of the grip.

24. The grip according to claim 17, wherein the grip is for a driver.

25. A golf club comprising:

a multi-positional club head;

a shaft configured to accommodate the multi-positional club head; and

a grip comprising a pattern such that a view of the grip is identical to a user for every position of the multi-positional club.

26. The club according to claim 25, wherein the club is a driver.

27. A golf club comprising:

a multi-positional club head;

a shaft configured to accommodate the multi-positional club head; and

a grip comprising an alignment marker such that a view of the marker is identical to a user for every position of the multi-positional club head.

28. The club according to claim 27, wherein the club is a driver.

**29.** A golf club comprising:  
a multi-positional club head;  
a shaft configured to accommodate the multi-positional club head; and  
a grip comprising a plurality of identical alignment markers, each marker corresponding to a position of the

multi-positional club head such that a view of the marker is identical to a user for every position of the multi-positional club head.

**30.** The club according to claim **29**, wherein the club is a driver.

\* \* \* \* \*