



US 20110065530A1

(19) **United States**

(12) **Patent Application Publication**
Molinari et al.

(10) **Pub. No.: US 2011/0065530 A1**

(43) **Pub. Date: Mar. 17, 2011**

(54) **ALIGNMENT GUIDE FOR A GOLF BALL**

(52) **U.S. Cl. 473/378**

(75) **Inventors:** **Arthur Molinari**, Beaverton, OR (US); **Michael F. Pai**, Lake Oswego, OR (US)

(57) **ABSTRACT**

(73) **Assignee:** **Nike, Inc.**, Beaverton, OR (US)

A golf ball with an alignment guide includes at least two lines of printing. A first line of printing includes arrows at opposite ends of the line of printing to act as the alignment guide. A second line of printing is printed with a different color than the first line of printing. The second line of printing is legible when viewed from a first angle and appears to fade when viewed from a second angle so that the second line of printing does not distract the golfer's eye from the alignment guide. The second line of printing may include metallic particles to enhance this effect.

(21) **Appl. No.:** **12/559,256**

(22) **Filed:** **Sep. 14, 2009**

Publication Classification

(51) **Int. Cl.**
A63B 37/12 (2006.01)

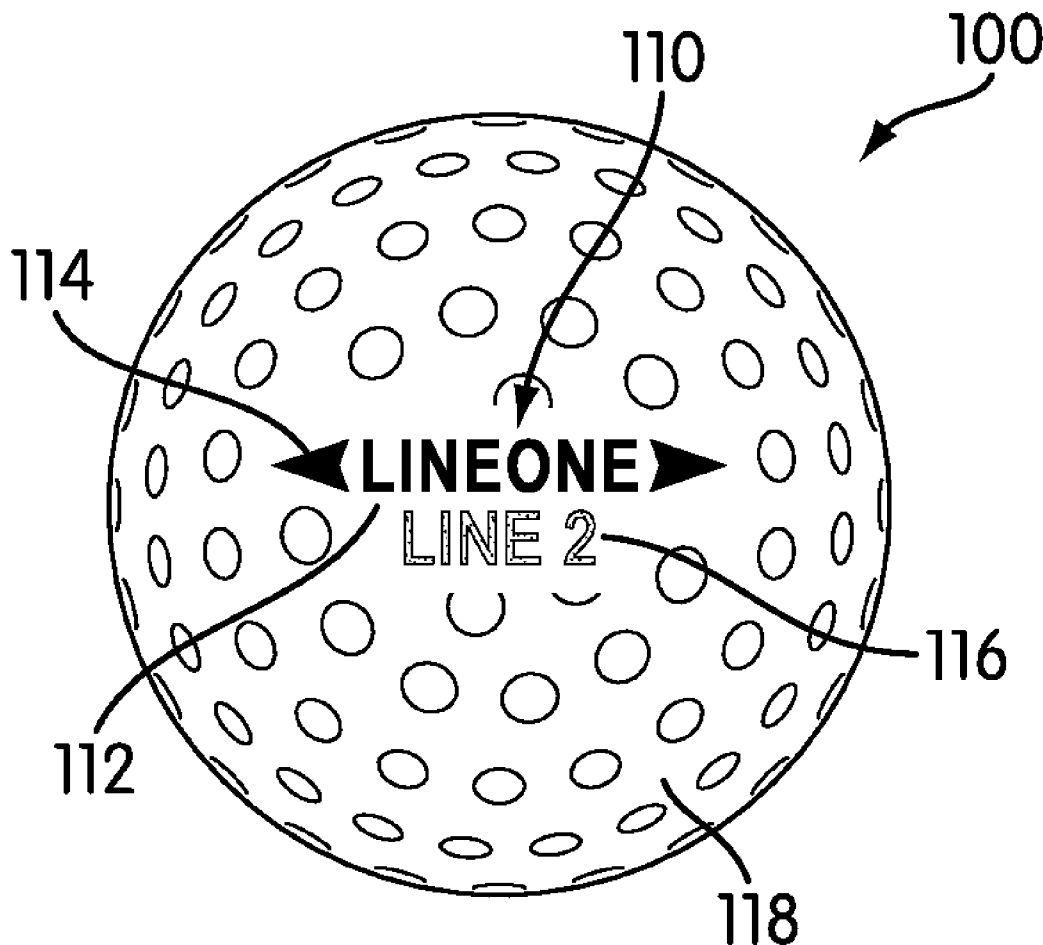

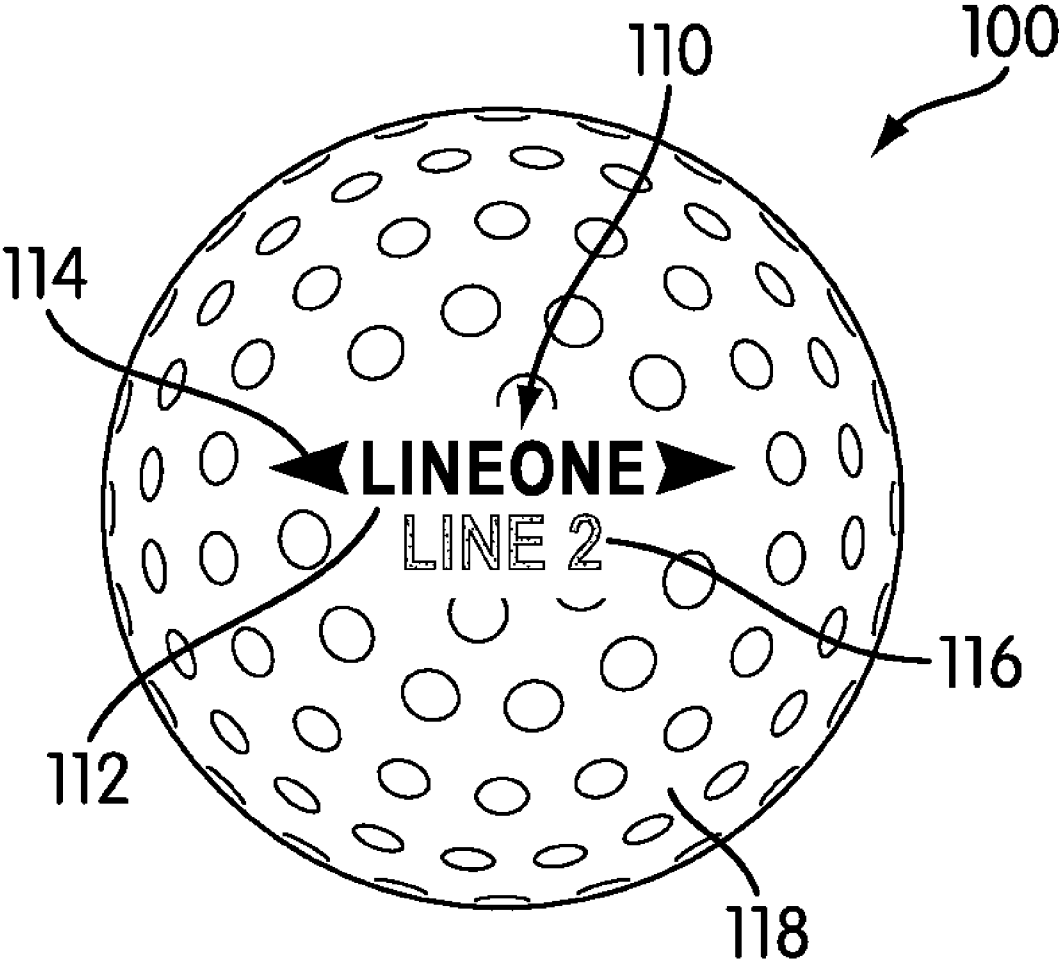

FIG. 1

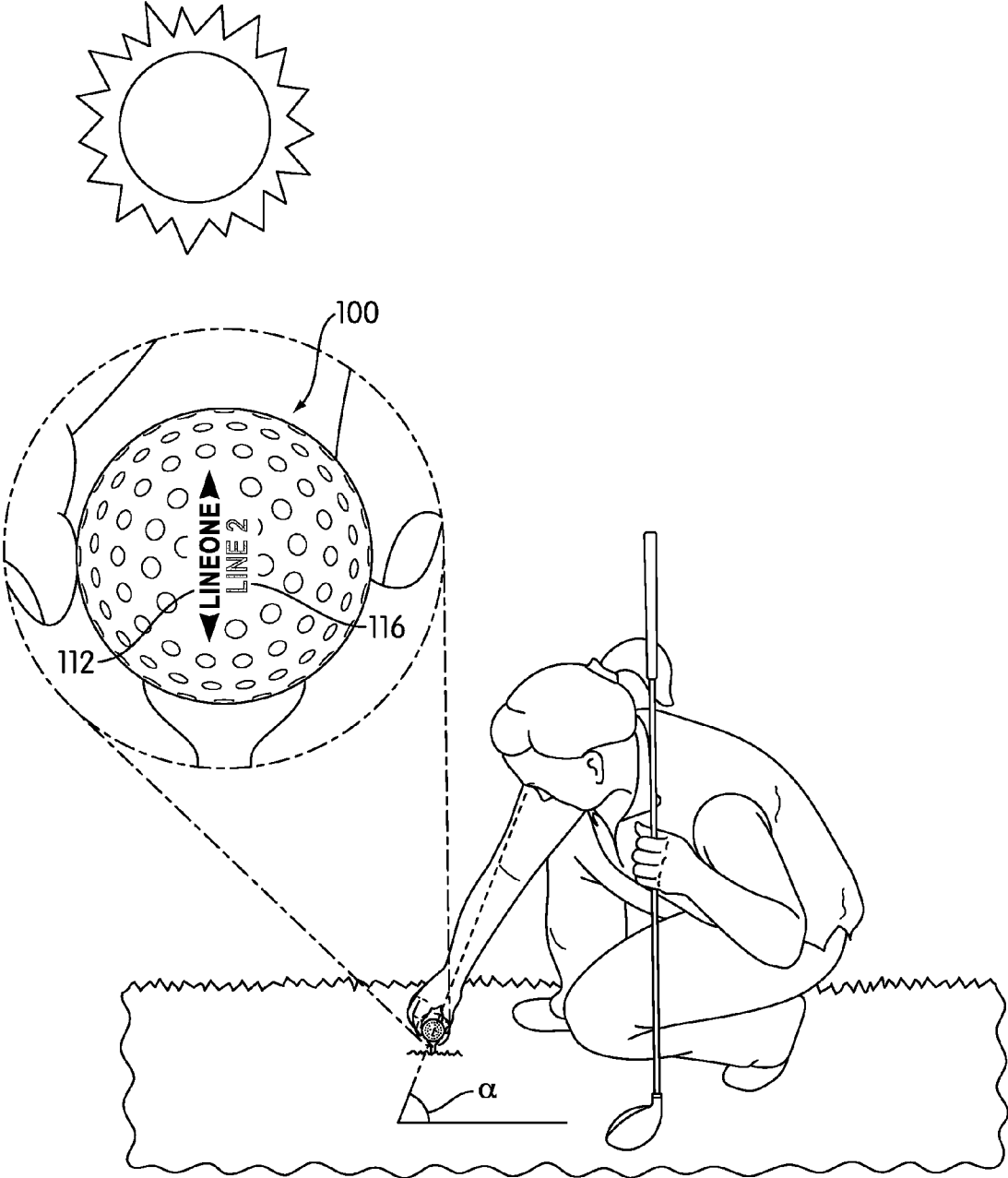

FIG. 2

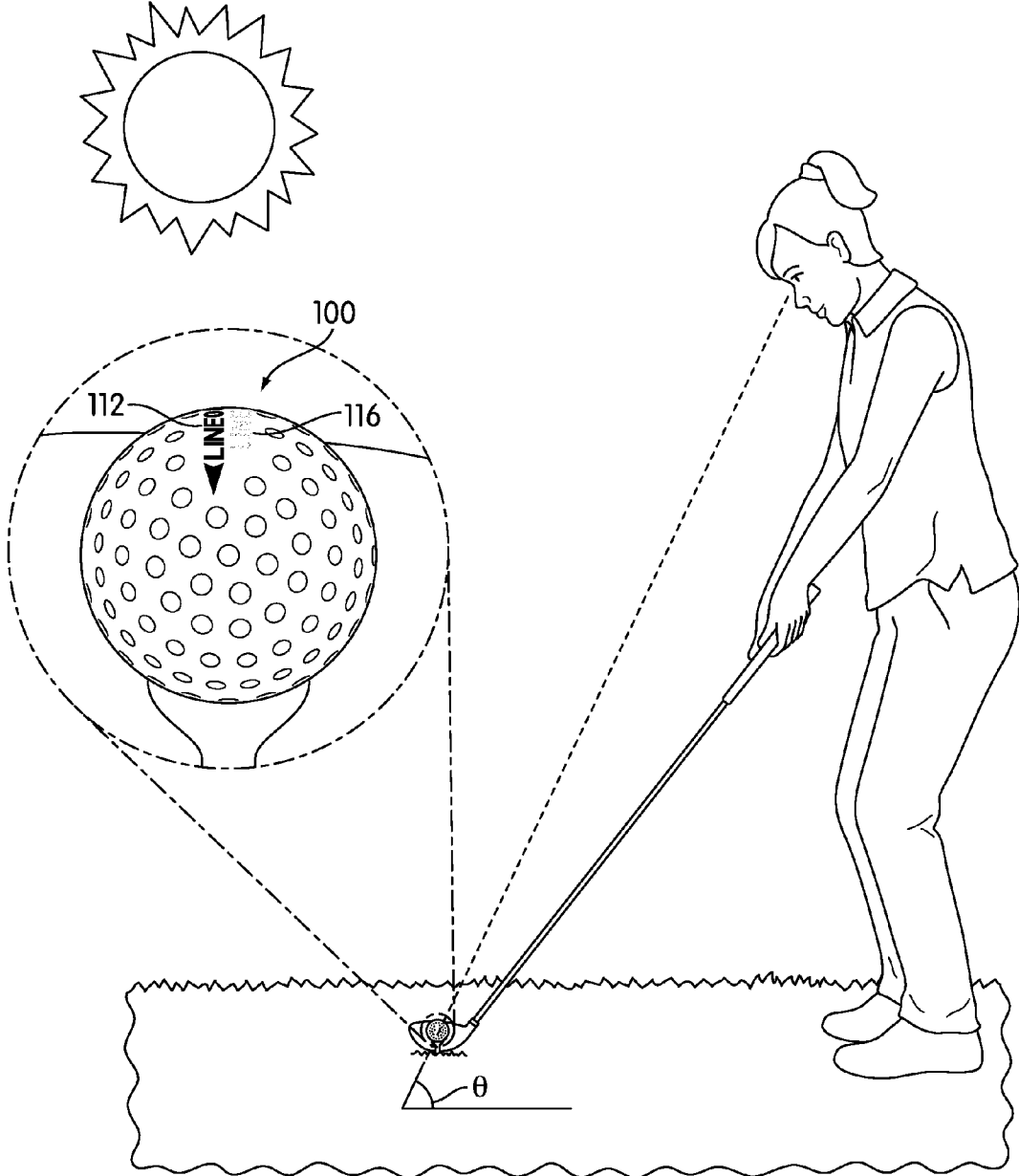

FIG. 3

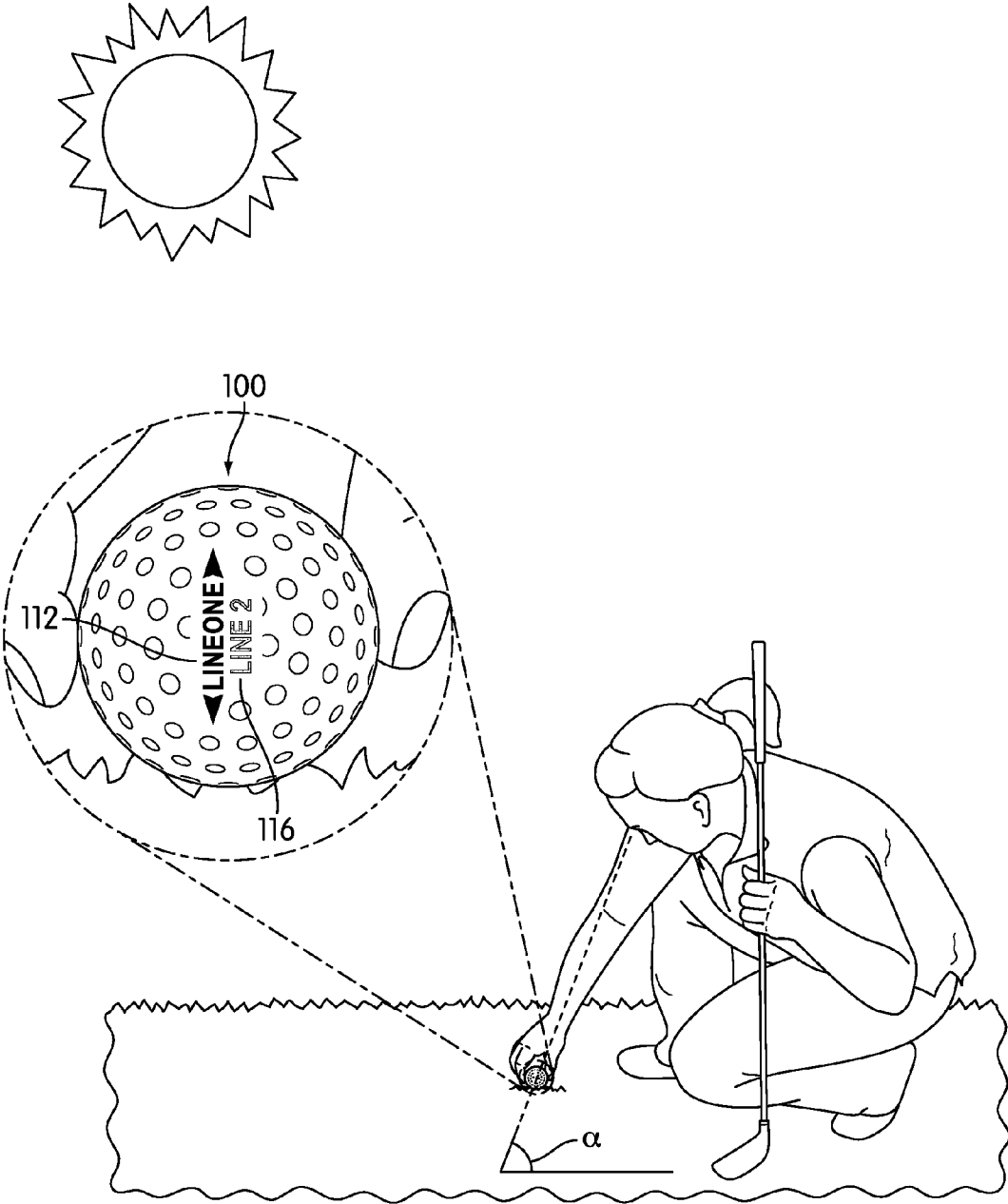

FIG. 4

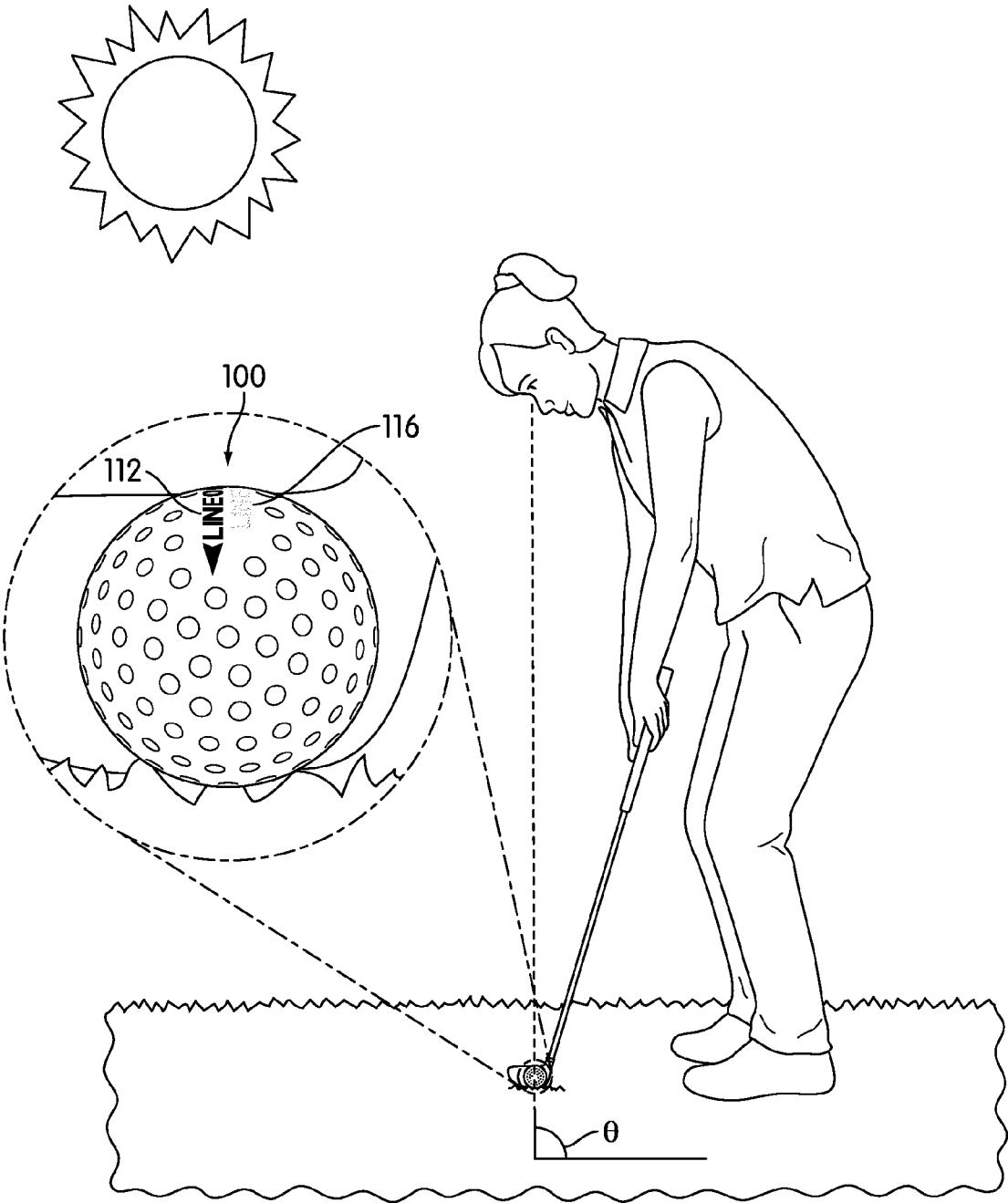

FIG. 5



FIG. 6

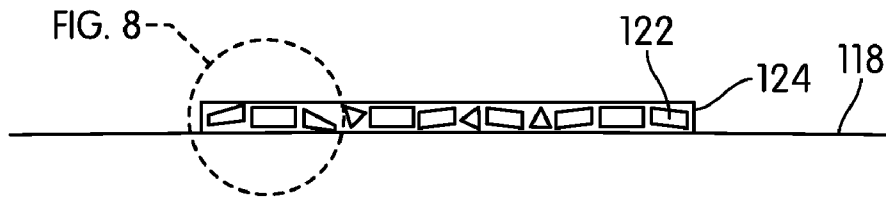

FIG. 7

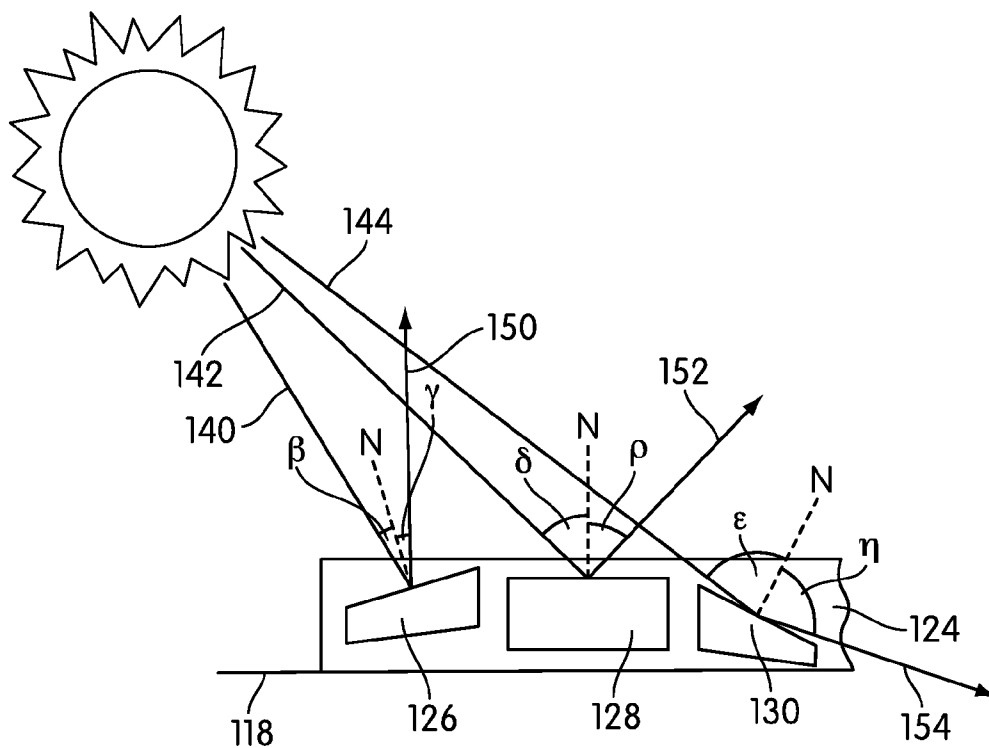

FIG. 8

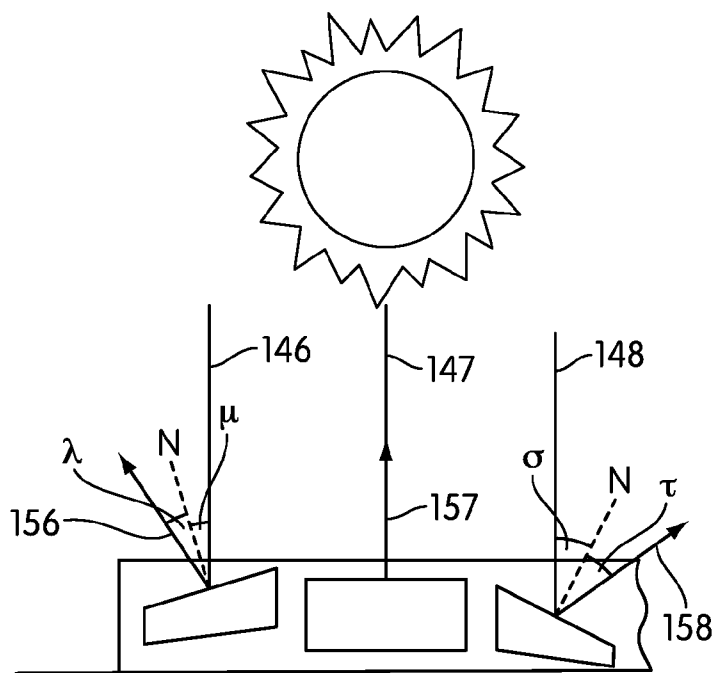

FIG. 9

$$\Delta E_{ab}^* = \sqrt{(L_2^* - L_1^*)^2 + (a_2^* - a_1^*)^2 + (b_2^* - b_1^*)^2}$$

Eq. 1

FIG. 10

ALIGNMENT GUIDE FOR A GOLF BALL

BACKGROUND

[0001] The present disclosure relates generally to indicia on a golf ball used as an alignment guide. More specifically, the present disclosure relates generally to two-line printing, where the first line is an alignment guide and the second line appears to fade when viewed from a pre-selected angle or group of angles.

[0002] Many golf balls include indicia. These indicia are often identifying words and/or graphics that assist a golfer in identifying the ball as her ball during play. Additionally, the indicia may also indicate the type of ball, such as the manufacturer's name, logo, or other identifying mark. The indicia may also indicate the specific brand name of the ball so that a golfer can readily select a desired ball from a group of balls.

[0003] Some balls use the indicia for the additional purpose of providing an alignment guide for the golfer when the golfer is able to rotate the ball. The alignment guide is typically printed words or graphics with arrows at the ends of the line. The printed words/graphics form a line so that the golfer's eye is drawn to the arrows to assist the golfer in aligning the golfer's shot.

[0004] The printed words/graphics are often the brand name of the ball and/or ball manufacturer so that a golfer can identify the golfer's ball throughout the round of golf. Many ball brand names are short enough to fit well on one line of printing. A single line of printing provides a clean basis for the "arrow" of the alignment guide, as the golfer's eye is not distracted from the alignment arrow. However, some ball brand names are longer and require two or more lines of printing. When two or more lines of printing are positioned proximate the alignment arrows, the golfer's eye may be distracted by the second line of printing, making the alignment guide less useful to the golfer or even unusable, depending upon the sensitivities of the golfer.

[0005] Therefore, a need exists in the art for an improved alignment guide that uses multiple lines of printing.

SUMMARY

[0006] In one aspect, the invention provides a golf ball comprising an indicia having a first line and a second line. The first line includes a graphic formed from a first color medium having a first color. The second line includes a second graphic formed from a second color medium having a second color, wherein the first color and the second color are different. The second color is selected so that the second line is legible when the indicia is oriented to the incident light at a first angle and appears to fade when the indicia is oriented to the incident light at a second angle.

[0007] In another aspect, the invention provides a golf ball having an alignment guide comprising an indicia having a first line and a second line, the indicia formed on a surface having a background color. The first line comprises a graphic formed from a first color medium having a first color, wherein the first line is the alignment guide. The second line comprises a second graphic formed from a second color medium having a second color, wherein the first color and the second color are different. The background color and the second color have low contrast, and the background color and the first color have high contrast.

[0008] Other systems, methods, features and advantages of the invention will be, or will become, apparent to one of

ordinary skill in the art upon examination of the following figures and detailed description. It is intended that all such additional systems, methods, features and advantages be included within this description and this summary, be within the scope of the invention, and be protected by the following claims.

BRIEF DESCRIPTION OF THE DRAWINGS

[0009] The invention can be better understood with reference to the following drawings and description. The components in the figures are not necessarily to scale, emphasis instead being placed upon illustrating the principles of the invention. Moreover, in the figures, like reference numerals designate corresponding parts throughout the different views.

[0010] FIG. 1 is a schematic plan view of an embodiment of a golf ball having an indicia with an alignment guide formed from a first line of and a second line of printing that will appear to fade when the alignment guide is being used at a selected angle or group of angles;

[0011] FIG. 2 is a schematic view of a golfer about to position on a tee an embodiment of a golf ball having an indicia with a line of printing that will appear to fade when an alignment guide is being used at a selected angle or group of angles;

[0012] FIG. 3 is a schematic view of a golfer having positioned on a tee an embodiment of a golf ball at a selected angle so that a line of printing of the golf ball indicia has appeared to fade;

[0013] FIG. 4 is a schematic view of a golfer about to position on a putting green an embodiment of a golf ball having an indicia with a line of printing that will appear to fade when an alignment guide is being used at a selected angle or group of angles;

[0014] FIG. 5 is a schematic view of a golfer having positioned on a putting green an embodiment of a golf ball at a selected angle so that a line of printing of the golf ball indicia has appeared to fade;

[0015] FIG. 6 is an enlarged schematic view of a line of printing with characteristics that will permit the line of printing to appear to fade when viewed from a selected angle or group of angles;

[0016] FIG. 7 is an enlarged partial cross-sectional view of an individual character of a line of printing with characteristics that will permit the line of printing to appear to fade when viewed from a selected angle or group of angles;

[0017] FIG. 8 is a schematic view of an enlarged partial cross-sectional view of an individual character of a line of printing with characteristics that permit the line of printing to appear to fade when viewed from a selected angle or group of angles showing how light hitting the individual character is reflected at a first angle;

[0018] FIG. 9 is a schematic view of an enlarged partial cross-sectional view of an individual character of a line of printing with characteristics that permit the line of printing to appear to fade when viewed from a selected angle or group of angles showing how light hitting the individual character is reflected at a second angle; and

[0019] FIG. 10 is an equation denoting the color difference between two colors in CIELAB color space.

DETAILED DESCRIPTION

[0020] A golf ball includes an indicia with multiple lines of printing, where only one of the lines of printing is used as an

alignment guide. The alignment guide is provided by arrows positioned at either end of only one line of the printing. The other line(s) of printing are printed with an ink that appears to fade or disappear when viewed by the golfer at a select angle or set of angles. This effect is an optical illusion that allows a golfer to ignore the lines of printing that are not part of the alignment guide so that the golfer can focus on the alignment guide without being distracted by other lines of printing proximate the alignment guide.

[0021] FIG. 1 shows an embodiment of a golf ball 100 with an indicia 110 disposed on a surface 118 of golf ball 100. Golf ball 100 may be any type of ball known in the art used for playing golf or training for golf, such as a solid ball or a wound ball. Golf ball 100 will typically include a core, one or more intermediate solid, viscous, or wound layers, and a cover.

[0022] Surface 118 may be any type of outer or outermost surface for a golf ball known in the art. Surface 118 may include the surface of the cover of golf ball 100, which cover may be made of a rubber, polymer, or plastic material. Surface 118 may also include any coating layers applied to the surface of the cover of golf ball 100. For example, the coating layer may include a paint layer, a sealing layer, or other type of coating. The cover of golf ball 100 may be any type of golf ball cover known in the art, such as a rubber, ionomer material, or a polyurethane material.

[0023] Surface 118 has a color visible to a golfer. The color of surface 118 may be considered to be the background color for indicia 110. For many golf balls, surface 118 has a white color. The precise shade of white of surface 118 may be selected from any shade of white. In other embodiments, surface 118 may have another color. Other common colors for golf balls include green, orange, and yellow, though any color may be used.

[0024] The color of surface 118 may be achieved by any means known in the art. For example, in some embodiments, the color of surface 118 may be provided by a paint layer, typically paint solids suspended in a polymer. The color of the paint layer is provided by the color of the paint solids or a mixture of colors provided by paint solids of multiple colors. In other embodiments, the color of surface 118 may be provided by particles mixed into the material of the cover layer of golf ball 100, such as titanium dioxide. In other embodiments, the color of surface 118 may be provided by a dye imparted to the cover layer of golf ball 100 using any method known in the art, such as sublimation or infusion dyeing techniques. In other embodiments, the perceived color of surface 118 by the golfer may be a combination of these and other colored outer layers of the ball. For example, the cover material may include titanium dioxide and a coating layer may include silvered metallic particles. The combination of these colored layers may impart a bright sparkling white color appearance to surface 118.

[0025] Indicia 110 may be marked on surface 118 or a coating disposed on surface 118 using any method known in the art, such as printing, dyeing, pad printing, stamping, ink jet printing, masking, screen printing, painting, adhered as a label, or the like. In some embodiments, indicia 110 may be locally integrated with surface 118 by a dyeing process such as sublimation dyeing or infusion dyeing. For clarity, in this discussion "printing" may be used to refer to any of the methods that may be used for depositing indicia 110, parts of indicia 110, and/or components of indicia 110 regardless of the

actual method used. For example, a "line of printing" may denote a series of printed characters, dyed characters, etc.

[0026] Indicia 110 may be formed from any type color medium known in the art, such as dye, paint, and ink. In some embodiments, more than one type of color medium may be used. Any subpart or component of indicia 110 may be monochromatic or include multiple colors, though it is contemplated that multiple colors will be used in different parts of indicia 110. For clarity, "color medium" will be used in this discussion to mean any type of color medium, such as ink, dye, paint, color particles, and combinations thereof, regardless of which type of color medium. Specific examples may discuss specific color medium materials.

[0027] Indicia 110 may be any type of marking made on the ball. Indicia 110 may include any type of graphic, such as alphanumeric characters, pictures, symbols, or combinations thereof. Indicia 110 may be an identifier so that the golfer may more readily identify a ball as the golfer's ball during play. For example, indicia 110 may include the ball manufacturer's name, trade name and/or logo, the ball name, trade name, brand name, and/or logo, a ball number, a custom graphic, and combinations thereof. For the purposes of clarity in this discussion, "character" may be used to denote any type of marking that is part of the indicia, regardless of the particular type of marking.

[0028] Many golf balls include an alignment guide to assist the golfer in lining up a shot. Alignment guides are particularly useful when on the green, as the golfer is permitted to rotate the golf ball as long as the ball's distance and vector to the hole is not changed. Alignment guides may take many forms, but are typically a line with arrows at either end of the line with the points of the arrows pointing away from each other. While a solid line may be provided, some indicia include alignment guides that utilize a line of printed graphics with arrows positioned at the ends of the line of printing. Such an alignment guide is shown in FIG. 1, as first printed line 112. Arrow graphics 114 are positioned at the beginning and terminus of first printed line 112, i.e., at the ends of first printed line 112. The golfer's eye readily interprets the line of printed graphics as a line comparable to a solid line so that the golfer can effectively use first printed line 112 as an alignment guide.

[0029] However, in many cases, the desired indicia may utilize multiple lines of printing. Indicia 110, as shown in FIG. 1, includes a second printed line 116. Any lines of indicia other than the alignment guide line are referred to in this disclosure as "additional lines". Indicia 110 may include any number of additional lines.

[0030] When indicia 110 includes multiple lines of printing or areas of coverage, the lines of printing not intended to serve as the alignment guide may distract the golfer's eye from the alignment guide. Therefore, indicia 110 provides a first color medium having a first color in the first printed line 112 and a second color medium having a second color in the second printed line 116. In some embodiments, the first color medium is the same as the second color medium, but the first color is different from the second color. In other embodiments, the first color medium is different from the second color medium, and the first color is different from the second color.

[0031] The color and/or color media of the additional lines of indicia 110 are selected so that the additional lines of indicia 110 appear to fade or disappear when the indicia is oriented at a selected angle or group of angles with respect to

the incident light and/or the viewing angle of the golfer. However, when viewed at any other angle, the additional lines of indicia **110** are clearly legible. The color and/or color media of the alignment guide line of indicia **110**, however, is selected to be clearly legible at all viewing angles.

[0032] FIGS. 2-5 show examples of how the visibility and/or legibility of the separate lines of printing on golf ball **100** change as the viewing angle of the golfer changes. FIGS. 2 and 4 show golf ball **100** being viewed at a first viewing angle α . At first viewing angle α , both first printed line **112** and second printed line **116** are clearly visible and/or legible. First viewing angle α may be any angle, but is in some embodiments any angle where golf ball **100** is not being viewed from the golfer's address position or putting stance. Additionally, golf ball **100** is rotated so that the incident light is not shining directly onto first printed line **112** and second printed line **116**.

[0033] FIGS. 3 and 5 show golf ball **100** being viewed at a second viewing angle θ , when the golfer is in the address position or in a putting stance. First viewing angle α is different from second viewing angle θ . Additionally, golf ball **100** is rotated so that the incident light is shining more directly onto first printed line **112** and second printed line **116**. When the golfer is viewing golf ball **100** from second viewing angle θ , second printed line **116** appears to fade or disappear.

[0034] While not being bound by any particular theory for why second printed line **116** appears to fade or disappear, the optical illusion of the fading print is likely linked to the color selection for second printed line **116** and/or the combination of the color selection of second printed line **116** and surface **118**. The color may be measured or described using any method, such as CIELAB, CIE XYZ, Pantone color chips and names, or the like. A high contrast color with surface **118** will tend to be visible and stay legible at most or all angles, while a low contrast color will tend to be legible at some angles and appear to fade or disappear at other angles. For example, if golf ball **100** is white, a lighter color (a gray, metallic silver, pale yellow, pink or the like) is a low contrast color that will tend to appear to fade or disappear at certain angles. A darker color (black, dark reds, dark blues, dark greens or the like) is a high contrast color that will tend to be visible and stay legible at all or nearly all angles.

[0035] In some embodiments, for example, second printed line **116** has a color selected to be similar to the color of surface **118** of golf ball **100** while the color of first printed line **112** is a highly contrasting color to that color of surface **118**. The color differential is sufficiently large so that second printed line **116** is legible and noticeable when viewed at some angles, but when the incident light hits second printed line **116** at a selected angle or group of angles, the difference in color between second printed line **116** and surface **118** is minimized so that second printed line **116** appears to blend in with the color of surface **118**. Because of the high contrast between the color of first printed line **112** and the color of surface **118**, first printed line remains highly visible and legible against the background of surface **118**. For example, for a typically white surface **118**, the color of first printed line may be black or a similarly dark hue while the color of second printed line **116** may be gray or silver.

[0036] One reason why the color of second printed line **116** appears to fade into the color of surface **118** may be that the angle of the incident light may change the proportion of the diffuse and specular reflection of light from the surface of golf ball **100** or the intensity of the specular reflection component

in the reflected light. In diffuse reflection, the reflected light is somewhat randomly scattered by imperfections in the surface (s) of golf ball **100**. A high proportion of diffuse reflection is familiarly known as a matte surface. In specular reflection, the reflected light is reflected in a single direction. A high proportion of specular reflection is familiarly known as a glossy surface. A very high proportion of specular reflection is a mirror or mirrored surface. This altering of the proportion of diffuse and specular reflection or the intensity of the specular reflection is particularly likely if reflective particles are used in the color medium for second printed line **116** or any of the additional lines of indicia **110** or if the color medium of second printed line **116** or any covering coatings has gloss or high gloss finish.

[0037] FIGS. 6-9 show how the alteration of the proportion of diffuse reflection to specular reflection could occur. FIG. 6 shows an enlarged view of second printed line **116**, where each individual character **120** of second printed line **116** is formed from a plurality of reflective particles **122** suspended in a matrix or base material **124**. In some embodiments, base material **124** may be clear or transparent, but in other embodiments base material **124** is provided with pigmentation so that base material **124** includes an opaque or translucent (partially opaque) color. For example, if the overall observed color of second printed line **116** appears to be silver, base material **124** may be provided with a gray color pigment. The metallic or glittery appearance is then provided by reflective particles **122**, which may be silvered particles with a metallic sheen and/or high luster. Reflective particles **122** may be any type of particle known to have a metallic sheen and/or high luster to cause a high amount of reflectivity. In other embodiments, all of the observed color of second printed line **116** is provided by the reflective particles **122**. For example, if second printed line **116** appears to be silver, the silvered particles with a metallic sheen and/or high luster provide the perceived color.

[0038] Reflective particles **122** may be randomly oriented within base material **124**, as shown in FIG. 7. In this configuration, the highest level of shine from the particles would not necessarily occur at the same angle. As shown in FIG. 8, three different reflective particles, first particle **126**, second particle **128**, and third particle **130** are hit, respectively, by first incident light ray **140**, second incident light ray **142**, and third incident light ray **144**. Each incident light ray is parallel to the other incident light rays. Because of the random orientation of the reflective particles, the incident light rays encounter the particles at different incident angles: first incident light ray **140** hits first particle at first incident angle β (measured from the normal line N to a particle surface); second incident light ray **142** hits second particle **128** at second incident angle δ ; and third incident light ray **144** hits third particle **130** at third incident angle ϵ , where each of these incident angles is different. Because the law of reflection requires that the reflected light rays are at the same angle to the normal line of the surface as the incident light rays, each particle produces reflected light rays at a slightly different angle: first particle **126** produces first reflected ray **150** at first reflected angle γ ; second particle **128** produces second reflected ray **152** at second reflected angle ρ ; and third particle **130** produces third reflected ray **154** at third reflected angle η . These different angles are all different, which produces diffuse reflection. Also, none of the particles is producing a reflected ray that travels back on the same path as the incident light ray. Such a ray is typically considered the highest level of reflection and can often "dazzle" the eye with a bright sheen or glare.

[0039] This dazzling effect is shown in FIG. 9, where the incident light hits at least one particle so that the highest level of reflection is achieved. Fourth incident ray 146 hits first particle 126 at a fourth incident angle λ which generates fourth reflected ray 156 at fourth reflected angle μ . Fifth incident ray 147 hits second particle 128 at a fifth incident angle of 0 degrees, which generates fifth reflected ray 157 which travels directly back on the same path as fifth incident ray 147 at a fifth reflected angle of 0 degrees. Sixth incident ray 148 hits third particle 130 at a sixth incident angle σ , which generates sixth reflected ray 158 at a sixth incident angle τ . While these reflections are also at slightly different angles so as to produce diffuse reflection, reflective particles 122 may settle within base material 124 so that many of reflective particles 122 may have the highest level of shine when the incident light shines at a specific angle or relatively small range of angles, such as when the light shines directly onto second printed line 116, as shown in FIG. 9. Further, having some particles achieve an extremely high level of reflection, such as when the angle of reflection is 0 degrees or between -15 and $+15$ degrees, the dazzle effect of this glare may be sufficient to shift the apparent proportion of diffuse and specular reflection.

[0040] Further, not every surface of reflective particles 122 may be highly reflective. For example, if reflective particles 122 are crystals, some facets of the crystal may have high luster and a metallic sheen while other facets of the crystal may have a more matte finish. Therefore, the reflective particles 122 may be more specifically oriented so that a high degree of reflection is only achieved when indicia 110 on golf ball 100 is oriented at a specific angle or a narrow range of angles with respect to the incident light. Additionally, the golf ball may include a coating with particles that can enhance this reflective effect, working in concert with the printing of second printed line 116.

[0041] Having the glare of reflected light impede the eye's ability to perceive details such as printing is familiar to anyone who has attempted to read a surface in bright sunlight. For example, when the sun shines directly onto the surface, the words on the surface are difficult or impossible to see. The characters on the surface are not clearly visible or legible. However, if the surface is oriented slightly differently, where the surface is not necessarily shaded but the angle of the sun incident to the surface is altered, such as when the observer moves with respect to the angle of the sun, the characters on the surface with higher contrast to the background of the screen become visible before the entire surface becomes legible. This effect is particularly common with backlit computer screens/displays.

[0042] Because the color of second printed line 116 is relatively similar to the color of surface 118, i.e., the color of second printed line 116 has a low contrast with the background color, the details of second printed line 116 become difficult to perceive when golf ball 100 is oriented so that a threshold level of glare is exceeded. However, because the color of the first printed line has a high contrast to the color of surface 118, first printed line 112 remains visible. This effect can be enhanced by the tendency of the eye to ignore low contrast objects when other objects in the field of view are much more high contrast. Thus, the alignment guide provided by first printed line 112 dominates the eye while the additional lines, such as second printed line 116 are effectively disregarded by the eye.

[0043] Thus, the golfer can readily read all lines of indicia 110 when golf ball is oriented to the incident light at angles that do not induce a high level of reflectivity and/or a high proportion of specular to diffuse reflectivity. Similarly, when golf ball 100 is oriented to the incident light at the relatively small range of angles or a specific angle that does induce a high level of reflectivity and/or a low proportion of specular to diffuse reflectivity, the additional lines of indicia 110 appear to fade or blend into the color of surface 118 of golf ball 100. This leaves only first printed line 112, the alignment guide, visible and legible to the golfer. This effect facilitates the golfer's ability to effectively utilize the alignment guide and not be distracted or disturbed in that use by the additional lines.

[0044] Table 1 provides CIELAB (formally, CIE 1976 L^* , a^* , b^* color space) color space values for various shades that are effectively disregarded by the eye when positioned on a curved white background and viewed as a selected angle or range of angles. Table 1 also provides the CIELAB value for the white shade. As is well-known in the art, CIELAB is a three-dimensional mathematical expression of color based upon the CIE 1931 color space chromaticity diagram. In CIELAB, L^* denotes the lightness of the color (0 indicating black and 100 indicating white), a^* denotes the position between red/magenta and green (negative values indicating green and positive values indicating magenta), and b^* denotes the position between yellow and blue (negative values indicating blue and positive values indicating yellow.) Table 1 is provided as an example only; Table 1 is not intended to be a comprehensive table of values for which the optical illusion of disregarding additional lines of printing is effective. Many other colors and color combinations are contemplated by the various embodiments of the invention.

TABLE 1

| Selected CIELAB Values | | | | |
|------------------------|-------|-------|-------|------------------------------|
| Color | L^* | a^* | b^* | ΔE^*_{ab} with White |
| White | 99.79 | -0.03 | -2.13 | NA |
| Light Gray | 96.21 | 0.07 | -0.03 | 4.15 |
| Metallic Silver | 96.92 | 1.10 | 0.35 | 3.79 |
| Dark Gray | 93.37 | 0.33 | 0.41 | 5.62 |

[0045] Using the example values as a guide, the relative perceptual differences (ΔE^*_{ab}) between White and the other colors was approximated by taking the Euclidean distance between them using the color difference equation Eq. 1 shown in FIG. 10. ΔE^*_{ab} is the metric used by the CIE to denote the color difference in CIELAB color space. As is known in the art, using this metric, a "just noticeable difference" (JND) is approximately 2.3 for CIELAB. The JND indicates the minimum difference in the color space that is perceived by the eye. In other words, a ΔE^*_{ab} of less than 2.3 results in the eye interpreting the two colors as the same color. Therefore, it was anticipated that the ΔE^*_{ab} for the colors shown in Table 1 would be relatively close to the JND.

[0046] As is shown in Table 1, the ΔE^*_{ab} values for Light Gray, Metallic Silver, and Dark Gray range from about 3.79 to about 5.62, all values within about 4 units of the JND. Therefore, in some embodiments, it is anticipated that the ΔE^*_{ab} for two colors that are effective for the optical illusion of having the eye disregard the additional lines of printing will be between about 2.3 and about 7. In other embodiments, this

range may be narrower or larger, for example between about 2.3 and about 15. Of note is that the ΔE^*_{ab} will, in most embodiments, be equal to or greater than the JND so that the print of the additional line is legible at some angles. Also, notably, the Metallic Silver color has the smallest ΔE^*_{ab} with respect to White, suggesting that inclusion of metallic particles will assist in the optical illusion of having the additional lines appear to fade so that they can be disregarded by the eye when viewed at some angles.

Example

[0047] A solid golf ball is manufactured with a cover made of an ionomer resin. A white paint layer is applied to the cover. Two indicia are provided on the cover, where the indicia is provided according to an embodiment of the invention. The indicia include an alignment guide which is provided in a black color. The alignment guide comprises a partial brand name for the ball with arrow graphics at the beginning and end of the partial brand name. Additional lines of the indicia are provided in a first indicia in Cool Gray 10 (a metallic gray tone with bluish undertones), NB 9522. In a second indicia on the opposite side of the ball, the additional lines are provided in PMS 877 Silver. The ball was then coated with a clear polyurethane coating.

[0048] The finished ball was observed with the light source positioned directly overhead by holding the ball so that the first indicia was facing the observer. Both lines of printing of the first indicia were visible and legible, though the additional line of printing was observed to be somewhat difficult to read. The finished ball was then rotated so that the first indicia faced upward, so that the first indicia faced the light source while the position of the observer did not change. The alignment guide was visible while the additional line appeared to fade and was no longer legible.

[0049] The ball was again rotated so that the second indicia faced the observer with the light source positioned directly overhead. Both lines of printing of the second indicia were visible and legible. The additional line of printing was observed to be the easier to read than the first indicia additional line of printing. The finished ball was then rotated so that the second indicia faced upward, so that the second indicia faced the light source. The alignment guide was visible while the additional line appeared to fade and was no longer legible.

[0050] While various embodiments of the invention have been described, the description is intended to be exemplary, rather than limiting and it will be apparent to those of ordinary skill in the art that many more embodiments and implementations are possible that are within the scope of the invention. For example, if surface 118 is provided with a color other than white, the color of the additional lines may be selected to have a similar color space value, such as having similar "a" and "b" values for CIELAB, but with a higher "L" value. Accordingly, the invention is not to be restricted except in light of the attached claims and their equivalents. Also, various modifications and changes may be made within the scope of the attached claims.

What is claimed is:

1. A golf ball comprising:

an indicia having a first line and a second line, the indicia formed on a surface having a background color;
the first line comprising a graphic formed from a first color medium having a first color;

the second line comprising a second graphic formed from a second color medium having a second color, wherein the first color and the second color are different; and wherein the second color is selected so that the second line is legible when the indicia is oriented to the incident light at a first angle and appears to fade when the indicia is oriented to the incident light at a second angle.

2. The golf ball according to claim 1, wherein the first color medium is selected so that the first line of printing is legible when the indicia is oriented to the incident light at the first angle and the second angle.

3. The golf ball according to claim 1, wherein the first line has a first end and a second end, wherein at least one of the first end and the second end includes an arrow graphic.

4. The golf ball according to claim 1, wherein at least one of the first line and the second line include alphanumeric characters.

5. The golf ball according to claim 4, wherein at least one of the first line and the second line includes a brand name.

6. The golf ball according to claim 1, wherein the first color has a first CIELAB value and the second color has a second CIELAB value.

7. The golf ball according to claim 6, wherein the second color includes reflective particles.

8. The golf ball according to claim 6, wherein the background color has a third CIELAB value which is different from the first CIELAB value of the first color and the second CIELAB value of the second color.

9. The golf ball according to claim 6, wherein a color difference between the second CIELAB value and the third CIELAB value is less than a pre-determined amount, and wherein the color difference is a relative perceptual difference as approximated by taking the Euclidean distance between the second CIELAB value and the third CIELAB value.

10. The golf ball according to claim 9, wherein the color difference is between a just noticeable difference value and about 15.

11. The golf ball according to claim 10, wherein the color difference is between about 2.3 and about 15.

12. The golf ball according to claim 9, wherein the color difference is between about 2.3 and about 7.

13. The golf ball according to claim 9, wherein the color difference is within about 4 units of a just noticeable difference.

14. The golf ball according to claim 9, wherein the color difference is between about 3.79 and about 5.62.

15. The golf ball according to claim 1 further comprising at least one additional line in the indicia, the at least one additional line comprising at least one additional graphic formed from a third color medium having a third color, wherein the first color and the third color are different; and

wherein the third color is selected so that the at least one additional line is legible when the indicia is oriented to the incident light at the first angle and appears to fade when the indicia is oriented to the incident light at the second angle.

16. The golf ball according to claim 15, wherein the second color is approximately the same as the third color.

17. A golf ball having an alignment guide for a golfer, the golf ball comprising:
an indicia having a first line and a second line, the indicia formed on a surface having a background color;

the first line comprising a graphic formed from a first color medium having a first color, wherein the first line is the alignment guide;

the second line comprising a second graphic formed from a second color medium having a second color, wherein the first color and the second color are different;

wherein the background color and the second color have low contrast; and

wherein the background color and the first color have high contrast.

18. The golf ball according to claim **17**, wherein the background color and the second color are within a predetermined distance in a color space.

19. The golf ball according to claim **17**, wherein the background color is a shade of white, and wherein the second color is lighter than the first color.

20. The golf ball according to claim **19**, wherein the second color comprises a metallic silver color and the first color comprises a black color.

* * * * *