



US 20110047830A1

(19) **United States**

(12) **Patent Application Publication**  
**Francello et al.**

(10) **Pub. No.: US 2011/0047830 A1**

(43) **Pub. Date: Mar. 3, 2011**

(54) **EXTENDABLE SPIKES FOR SHOES**

**Publication Classification**

(76) Inventors: **Gene A. Francello**, Escondido, CA (US); **Eric Nelson**, Canyon Country, CA (US); **Helen K. Park**, La Habra, CA (US)

(51) **Int. Cl.**  
*A43B 5/00* (2006.01)  
*A43B 13/20* (2006.01)  
*A43C 15/00* (2006.01)

(52) **U.S. Cl.** ..... **36/134; 36/29; 36/61**

(21) Appl. No.: **12/802,899**

(57) **ABSTRACT**

(22) Filed: **Jun. 16, 2010**

**Related U.S. Application Data**

(63) Continuation-in-part of application No. 12/583,670, filed on Aug. 25, 2009.

Golf shoe sole 10 having extendable spikes 71 activated by compressed air from a pump 42 located inside sole of shoe. Pump 42 is operated by weight of wearer's heel on a bladder 41 located in heel of sole and check valves 51 maintain pressure in pneumatic system. Pushbutton switch 58 selects movement of spikes 71 between retracted and extended modes.

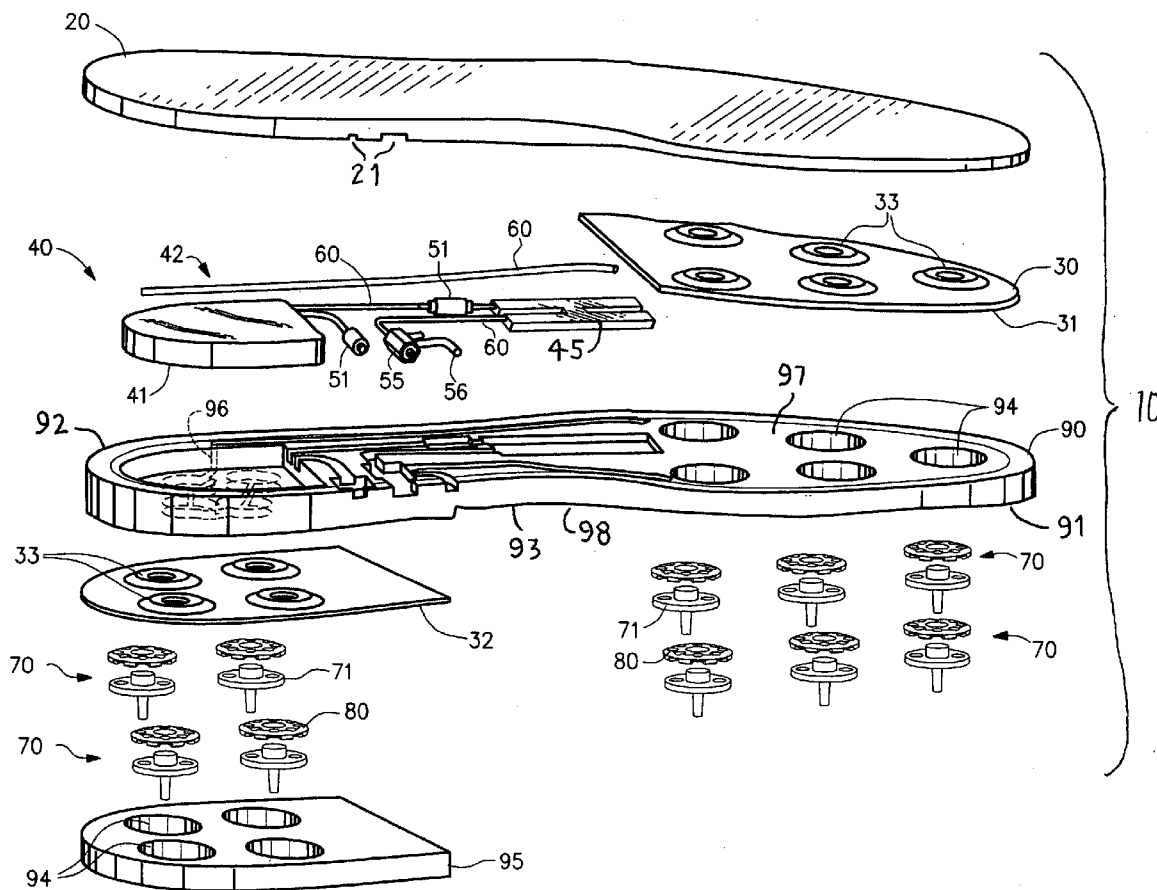

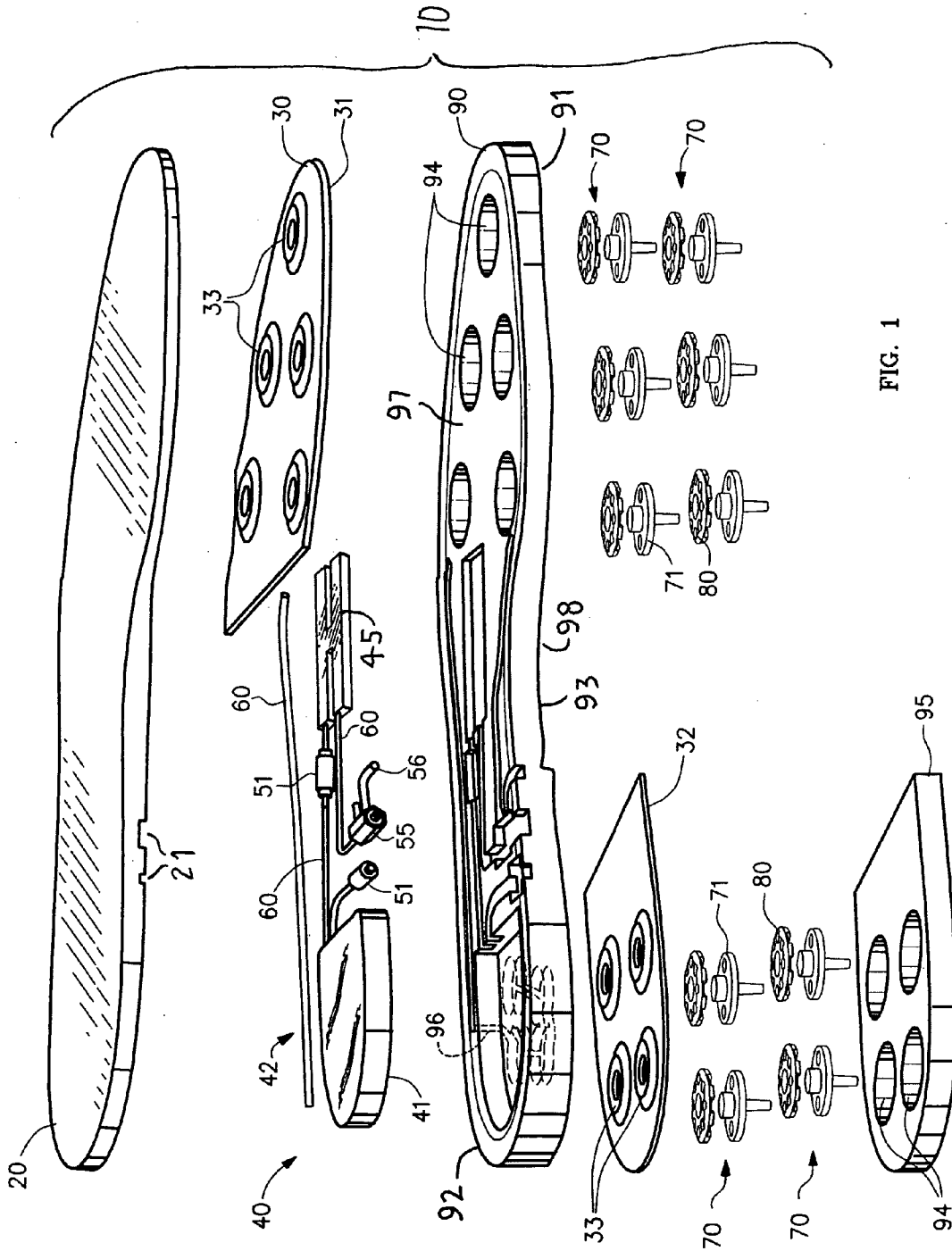

FIG. 1

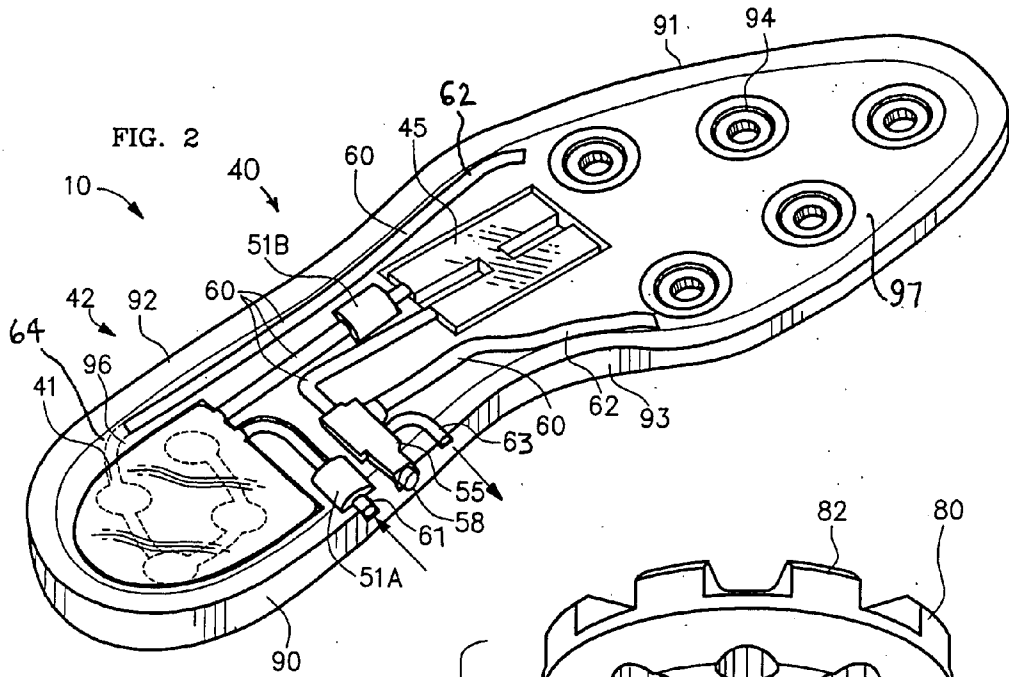

FIG. 4

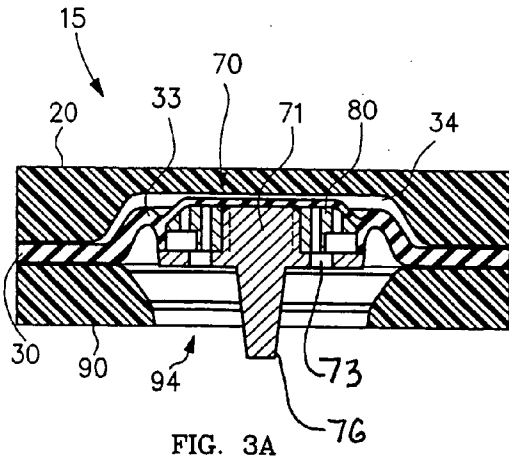
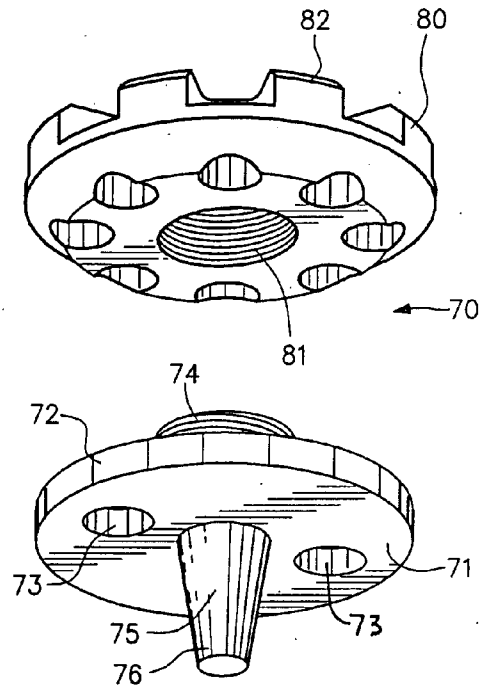

FIG. 3A

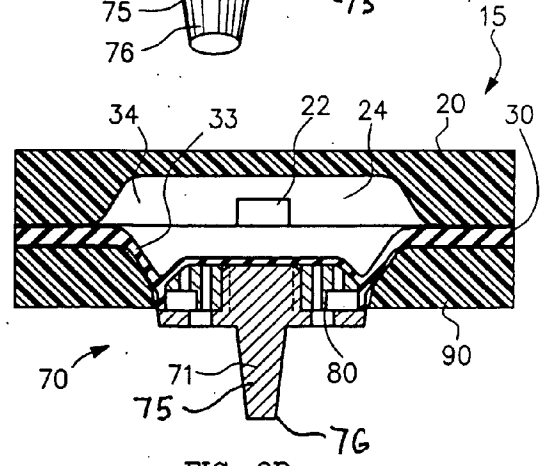
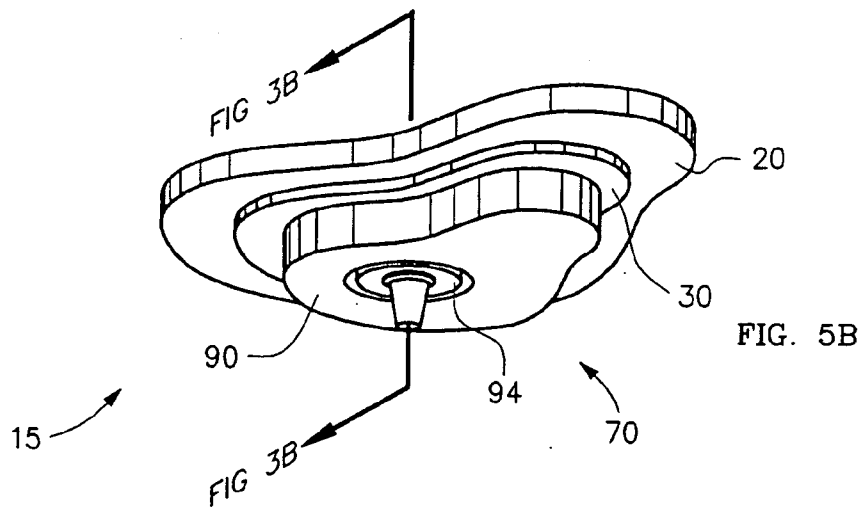
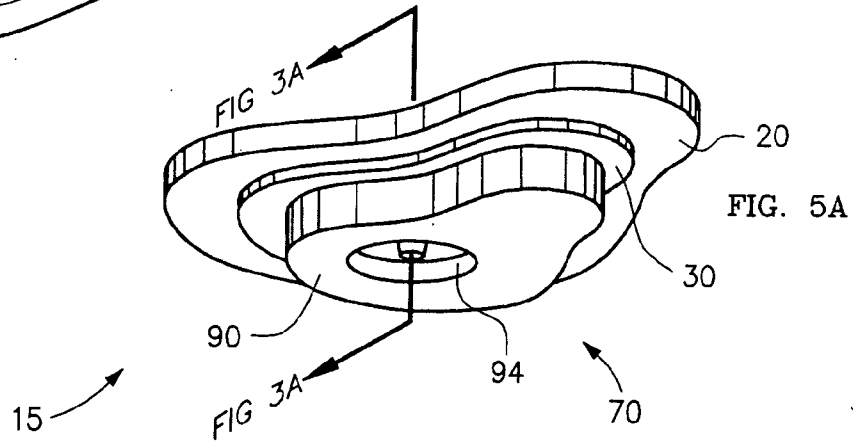
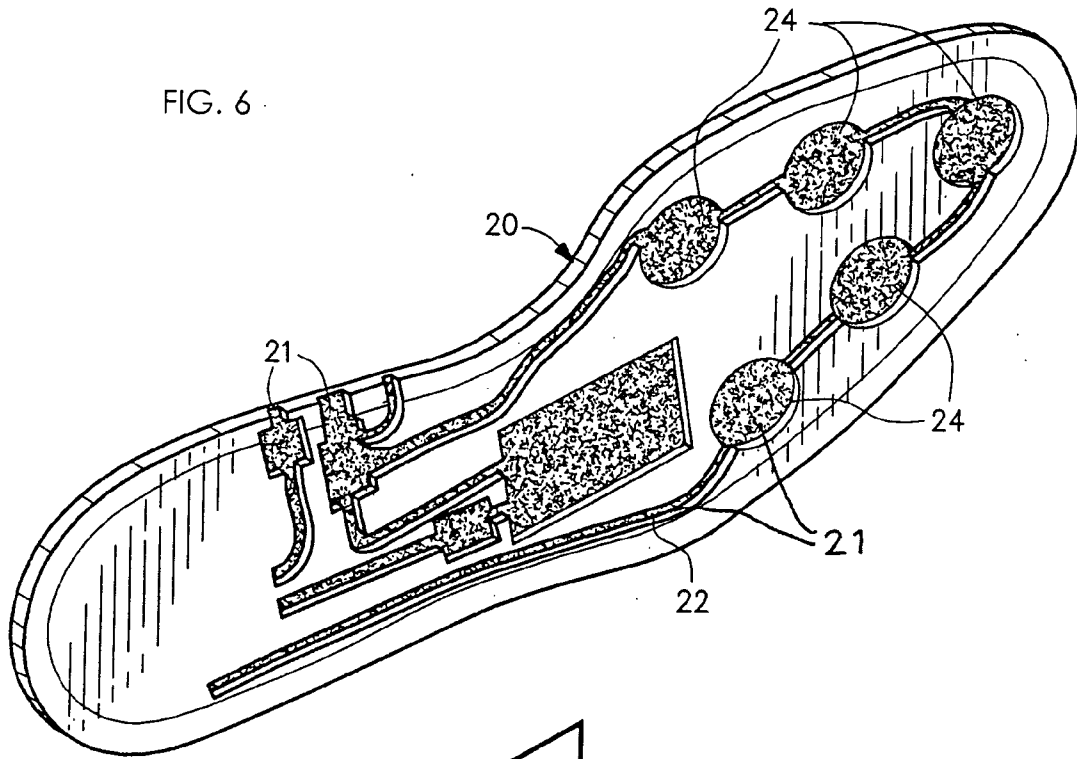
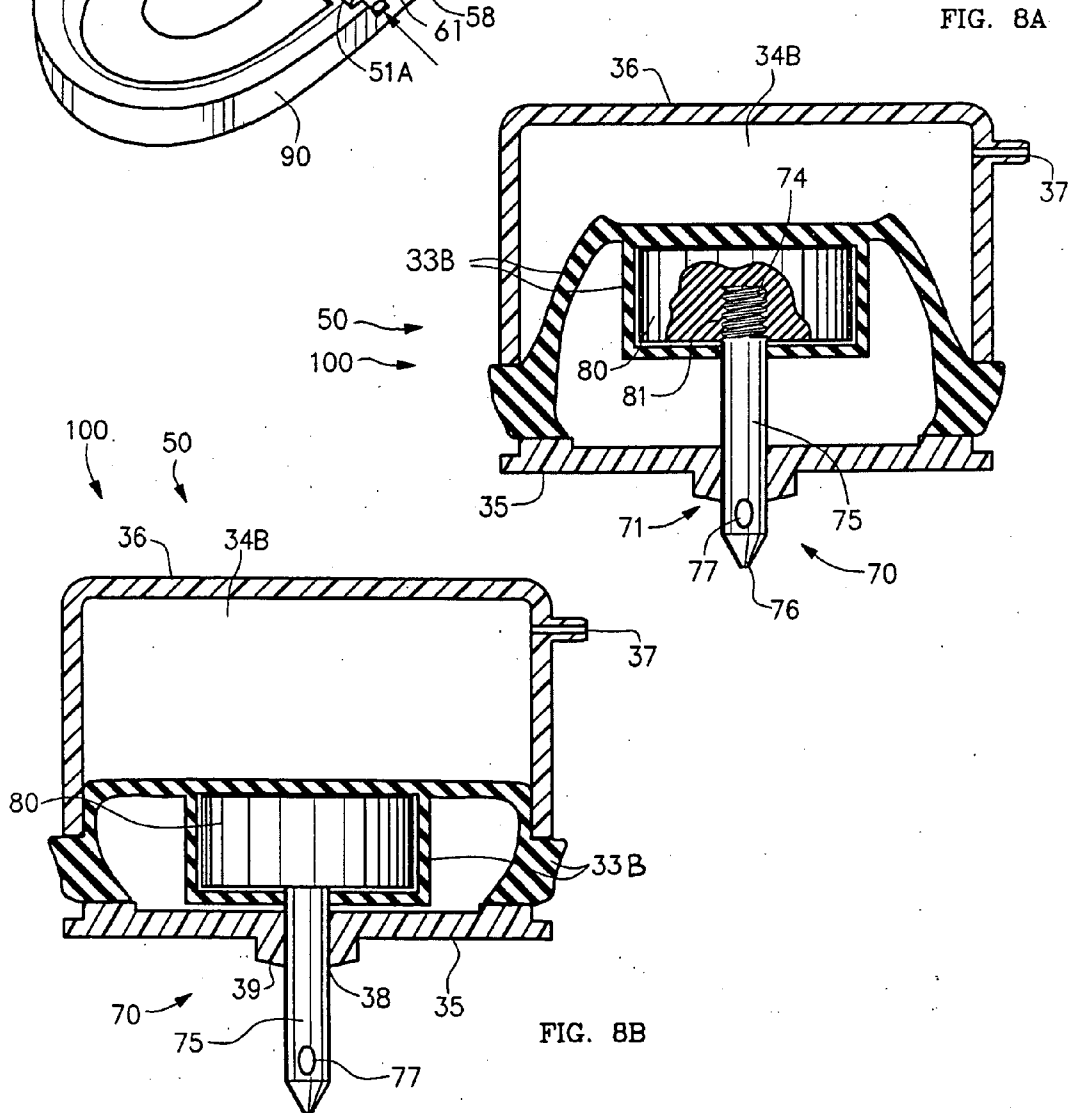
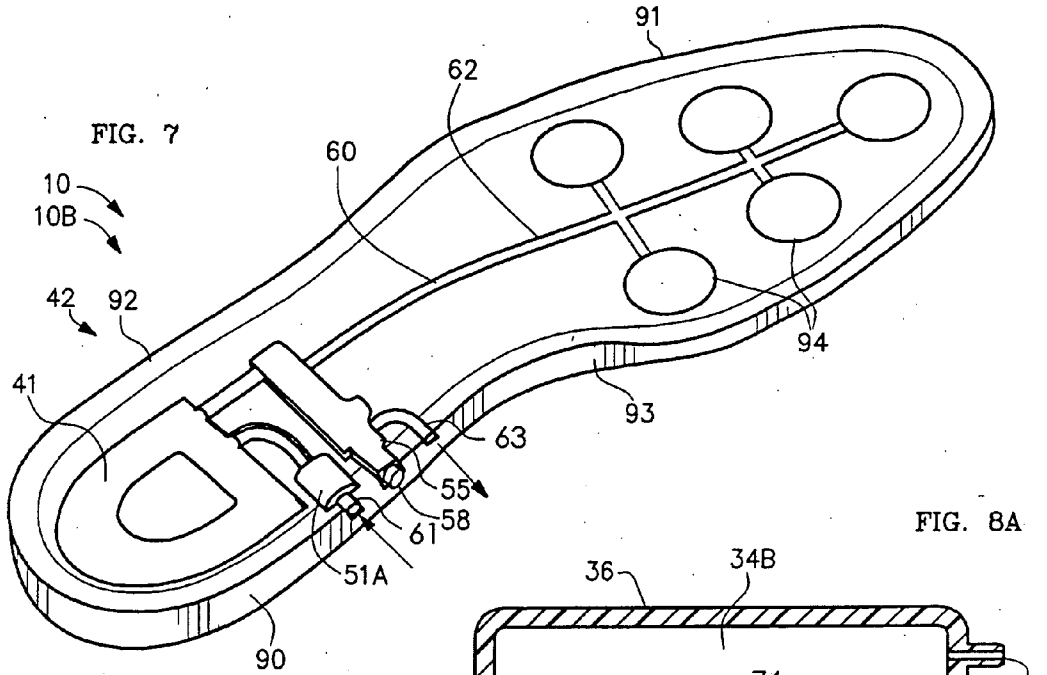

FIG. 3B

FIG. 6





**EXTENDABLE SPIKES FOR SHOES**

**CROSS-REFERENCE TO RELATED APPLICATIONS**

[0001] This application is a continuation-in-part of and claims the benefit of co-pending U.S. patent application Ser. No. 12/583,670, filed Aug. 25, 2009, the disclosures of which are hereby expressly incorporated by reference.

**FIELD OF THE INVENTION**

[0002] This invention relates generally to sports shoes and more specifically involves spikes for a shoe, which are extended or retracted by the wearer's footsteps.

**BACKGROUND OF THE INVENTION**

[0003] Shoes with spikes or cleats are often worn for sports that require good foot traction. For example, golf players use spiked shoes for safer and more stable walking and standing on wet grass and slopes. Other conditions where shoes with retractable spikes are desirable include walking or climbing on ice or snow.

[0004] Historically, golf shoes had small metal spikes attached to the soles, such as by a threaded connection in the sole. Such spikes were durable and provided good traction, but damaged the grass of golf courses and scratched or gouged interior floors. Golf players were typically required to remove their spiked shoes before entering offices or clubhouses associated with golf courses. Most golf courses have now even banned or restricted use of metal spikes altogether.

[0005] Another type of golf spike that is less damaging to grass and floors is a blunt spike of hard plastic, which may be single- or multi-pronged. Most golf courses allow these plastic spikes to be used both on grassy fairways and on most interior surfaces.

[0006] Plastic spikes have four main disadvantages. First, they can still damage the finely groomed grass of the greens, and even leave a slight indentation.

[0007] Second, on some surfaces, plastic spikes are more slippery than most conventional shoes. For example, on a smooth or wet floor or exterior walking surface, plastic spikes can cause the wearer to slip and fall.

[0008] Third, plastic spikes are not as durable as metal ones. Although the grass of the actual golf course does not wear out plastic spikes too quickly, walking on concrete sidewalks and parking lots, for example, does shorten the life of plastic spikes greatly.

[0009] Fourth, plastic spikes collect grass and mud that reduces their ability to provide good traction with the ground.

[0010] Attempts have been made to provide non-damaging shoes for golf by including mechanisms to extend the spikes only when needed. Such mechanisms include cleats that are cranked by hand or moved by one or more levers. These retracting spikes have been found to have certain disadvantages of their own. For example, the mechanism may be prone to becoming jammed by mud or rust. The mechanism may be so difficult to operate that it is necessary to sit down to safely extend or retract the spikes. The inevitable mud and grass that creep into the moving parts cause wear and corrosion, shortening the useful life of the mechanism. Mechanical mechanisms add to the weight of the shoe and make the sole less flexible. Thus, despite attempts to create better shoes, golf players still have considerable inconvenience associated with their footwear.

[0011] There is a great need for shoes that provide traction when needed but that do not have the disadvantages of conventional golf spikes. There is further a need for spikes that do not damage golf greens or other fine-textured grass. There is a need for a golf shoe that can be worn on the course, in the clubhouse or other buildings, and for walking on sidewalks and across parking lots without excessive wear. There is a need for a durable spiked shoe that is safe to walk in on all surfaces.

[0012] In the case of retracting spikes, there is a need for a shoe that is easy enough to operate that it does not interrupt the game unduly or require the user to sit. Such a shoe would preferably be self-contained and not require the wearer to carry auxiliary equipment or replace expendable parts.

**SUMMARY OF THE INVENTION**

[0013] The present invention is a sole assembly for a shoe for golf or other sports, with plastic or metal spikes that may be easily extended when needed and retracted when not needed. The spikes are activated by pneumatic pressure that is generated by the wearer's own walking action. The selection mechanism for extending or retracting the spikes is a switch that can be operated with a single click.

[0014] The sole assembly includes an integral pump that selectively compresses air, powered by the wearer's weight. The compressed air expands plenum chambers that exert downward force on spike assemblies. Air pressure is maintained by check valves. The spikes protrude from apertures in the outsole then retract when air pressure is released. Mud and grass are scraped from the spikes as they retract.

[0015] Plenum chambers are embedded between midsole and outsole. Each spike is attached to a rigid ferrule, which moves like a piston inside the complementarily-shaped chamber. The ferrule is connected to, or embedded within, a flexible plenum membrane. The chamber walls support the plenum membrane such that over-distortion of the material does not occur, thereby prevent cracking of the rubber from stress.

[0016] The plenum membranes are biased in an upward position. When air pressure is released by actuating the switch, membranes, ferrules, and attached spikes retract into the sole.

[0017] All components of the sole assembly, including valves, may be constructed from synthetic polymeric materials to avoid corrosion and any need for external lubrication. The pump device consists of a compressible bladder and an optional pressure reservoir, both made of resilient rubber. They are designed to flex with the sole assembly and not create discomfort to the wearer. All materials are selected for durability and reliability of the sole assembly.

**BRIEF DESCRIPTION OF THE DRAWINGS**

[0018] FIG. 1 is an exploded side perspective view of a first preferred embodiment of the sole assembly of the present invention.

[0019] FIG. 2 is a top perspective view of the outsole portion of the sole assembly of FIG. 1, with most pneumatic components in place.

[0020] FIGS. 3A and 3B are cross sectional views taken along lines 3A-3A and 3B-3B of FIGS. 5A and 5B, respectively, of a first preferred embodiment of plenum chambers and spike assemblies shown in retracted and extended positions, respectively.

[0021] FIG. 4 is an enlarged, exploded perspective of the spike assembly of FIG. 1.

[0022] FIGS. 5A and 5B are top, side perspective views, partly cut away, of the sole assembly of FIG. 1 in the retracted and extended positions, respectively.

[0023] FIG. 6 is a bottom perspective view of the midsole portion of the sole assembly of FIG. 1.

[0024] FIG. 7 is a top perspective view of the outsole portion of a second preferred embodiment of the sole assembly of the present invention.

[0025] FIGS. 8A and 8B are cross-sectional views showing an alternative preferred embodiment of plenum chambers and spike assemblies in retracted and extended positions, respectively.

#### DETAILED DESCRIPTION OF THE INVENTION

[0026] The present invention is a system of extendable spikes for a sole assembly 10 that may be attached to many styles of shoe upper (not shown) to create a shoe with cleats or spikes that may be extended or retracted depending on need.

[0027] FIG. 1 is an exploded side perspective view of sole assembly 10 of a first preferred embodiment 10A of the present invention. Sole assembly 10A generally includes a midsole 20 for attaching to a shoe upper, an outsole 90 for providing a durable walking surface, spike assemblies 70 that selectively protrude from the bottom of outsole 90, and a pneumatic system 40 that activates the movement of spike assemblies 70 by compressed gas, such as air.

[0028] Outsole 90 includes a front portion 91 for supporting the front part of a foot, a rear portion 92 for supporting the heel of a foot, and an arch portion 93 for supporting the arch of a foot. Typically, a shoe heel 95 of especially durable material is attached to the bottom of rear portion 92. With shoe heel 95 attached, heel 95 and front portion 91 contact the ground when the wearer walks; arch portion 93 either does not contact the ground or does not bear much weight.

[0029] Outsole 90 preferably includes shallow cut-outs in its upper face, to accommodate components of pneumatic system 40. A plurality of apertures 94 pierce outsole 90 from upper face 97 to bottom face 98. Apertures 94 also pierce shoe heel 95 in like manner. Pneumatic system 40 further includes heel pneumatic subsystem 43, which activates the movement of spike assemblies 70 through shoe heel 95.

[0030] Midsole 20 and outsole 90 are attached together, such as by adhesive as is well known in the art, with a plenum membrane 30 sandwiched between. Midsole 20, outsole 90, and plenum membrane 30 when attached together collectively form a sole body 15. Plenum membrane 30 is a sheet of strong resilient material such as nitrile, Viton, silicone rubber, or other suitable material, which includes a plurality of plenum members 33 formed into it, such as by a molding process. Plenum membrane 30 may be front plenum membrane 31, adapted to be sandwiched between midsole 20 and front portion 91 of outsole 90; or may be heel membrane 32, adapted to be sandwiched between rear portion 92 of outsole 90 and shoe heel 95.

[0031] Sole assembly 10 further includes a plurality of spike assemblies 70, consisting of a spike body 71 for providing traction and a ferrule 80, which might also be comprehended as a thrust bearing for moving spike body 71 between a retracted and an extended position.

[0032] FIG. 2 is a top perspective view of outsole 90, with many of the components of pneumatic system 40 installed in their respective cut-outs. Looking at FIGS. 1 and 2, pneu-

matic system 40 includes pump means 42 for supplying compressed air to activate spike assemblies 70, switch valve 55, and sections of tubing 60 connecting the components such that compressed gas can be conducted to spike assemblies 70 or released to the atmosphere, as needed.

[0033] Pump means 42 is for supplying compressed air to activate movement of spike assemblies 70 from retracted to extended position. In the first preferred embodiment 10A shown and described in FIGS. 1-5, pump means 42 consists of a hollow, compressible bladder 41, a compressed air reservoir 45 in pneumatic communication with bladder 41, such as being connected by tubing 60, and two check valves 51A, B for maintaining air pressure within pneumatic system 40 at a selected value. Compression of bladder 41, such as by the wearer's weight during walking, forces air into reservoir 45, where pressure builds with each step.

[0034] Other means for providing compressed air through a wearer's walking movement are envisioned but not illustrated, such as a flexible hollow pipe arranged in serpentine fashion within sole body 15 so as to be compressed progressively from rear to front as the wearer steps first on heel 95 then transfers weight toward front portion 95.

[0035] Bladder 41 has a resilient bias toward being in an expanded position. Bladder 41 is compressed by the weight of the wearer's downward step and the air inside bladder 41 is forced into reservoir 45. As the wearer steps forward and lifts weight from above bladder 41, bladder 41 returns to the expanded position, drawing in additional air through inlet tube 63.

[0036] Bladder 41 is most efficiently shaped to conform to the outline of the bottom of wearer's heel, although design details may vary. Reservoir 45 may be of the same shape as bladder 41 or of other shapes chosen for efficient operation and fit within sole assembly 10. In the preferred embodiment illustrated herein, reservoir 45 is shown as a pair of elongate tubes that are connected together. The reason for separating reservoir 45 into two elongate halves is to provide a shape that flexes with the wearer's foot so as not to impede walking.

[0037] A plurality of apertures 94 disposed in front portion 91 of outsole 90 are shaped to receive plenum members 33 and ferrules 80 from above and spike bodies 71 from below. In the preferred embodiment shown and described herein, plenum members 33 are portions of plenum membrane 30 that are formed during the molding process to be in the shape of dome springs that are upwardly biased. The complex shape of plenum members 33 can best be understood from FIG. 3, as will be explained below.

[0038] FIG. 4 is a bottom perspective view of spike assembly 70. Spike assembly 70 includes spike body 71 and ferrule 80. Spike body 71 includes a threaded connector 74, and ferrule 80 includes a threaded hole 81 for accepting threaded connector 74. Ferrule 80 has a top surface 82.

[0039] Spike body 71 further includes a flange 72 and a spike shaft 75 including a tip 76 for contacting the ground and increasing traction. Flange 72 includes a plurality of engagement holes 73 for accepting a pronged tool (not shown) to aid connecting and disconnecting spike body 71 to and from ferrule 80, such as to replace spike body 71 if tip 76 is damaged.

[0040] Each plenum member 33 is attached to top surface 82 of one ferrule 80. This may be accomplished by gluing. In the most preferred embodiment, plenum members 33 are created by molding suitable material in the shape of front membrane 31 and heel membrane 32. Furthermore, it is most

preferred to attach ferrules **80** to plenum members **33** by the process of co-molding, as is well known. That is, an appropriate number of ferrules **80** are placed into a prepared mold then the molten rubber material is forced into the mold to create front and heel membranes **31**, **32** in which each ferrule **80** is embedded strongly beneath ene-its associated plenum member **33**.

[0041] Plenum members **33** may alternatively be individual units that are not connected together. Plenum members **33** may take various forms other than the one illustrated and described herein, as may be readily appreciated by those skilled in the art.

[0042] FIGS. **5A** and **5B** are top, side perspective views, partly cut away, of sole assembly **10A** of FIG. **1** in the retracted and extended positions, respectively. FIG. **6** is a bottom perspective view of the midsole portion of the sole assembly of FIG. **1**.

[0043] As seen in FIG. **6**, the bottom face of midsole **20** includes plenum cutouts **24** that mirror the position of apertures **94** in outsole **90**. However, plenum cutouts **24** are relief cutouts only and do not pass through midsole **20**. Plenum cutouts **24** are connected in series by air channel **22**. Air channel **22** is disposed so as to align with the outlet of supply tube **62**, best seen in FIG. **2**.

[0044] When outsole **90**, plenum membrane **30**, and midsole **20** are attached together to create sole body **15**, air channel **22** cooperates with supply tube **62** to supply compressed air to all plenum members **33** of front plenum membrane **31**. After passing through air channel **22**, compressed air enters heel tubing **64** and is conducted downwardly through borehole **96** to activate plenum members **33** of heel membrane **32**.

[0045] Looking especially now at FIGS. **3A** and **3B**, it can be seen that spike assembly **70** is moved from a retracted position (FIG. **3A**) to an extended position (FIG. **3B**) by expansion of plenum (or "expansion") chamber **34**. In FIG. **3A**, plenum chamber **34** is in contracted position, plenum member **33** of plenum membrane **30** and ferrule **80** are almost entirely retracted within plenum cutout **24**, and spike tip **76** barely protrudes below the bottom surface of outsole **90**.

[0046] In FIG. **3B**, plenum chamber **34** is in expanded position due to introduction of compressed air through air channel **22**, the end of which is seen at the back of plenum chamber **34**. Plenum chamber **34** is defined by plenum cutout **24** forming its upper wall and the upper portion of the side walls and by plenum member **33** forming its bottom wall and bottom portion of side walls. Plenum cutout **24** is relatively rigid and is unaffected by introduction of compressed air. Plenum member **33** is resilient and movable, and everts downward when the pressure within plenum chamber exceeds its design value, typically about 5-45 psi. When plenum member **33** is forced downward as in FIG. **3B**, it pushes spike assembly **70** to its extended position in which the entire spike shaft **75** protrudes below the bottom of outsole **90**.

[0047] In FIG. **3A**, plenum member **33**, in contracted position, can be seen to be a generally dome-shaped portion of plenum membrane **30**, with spike assembly **70** attached beneath the upwardly-biased dome. In FIG. **3B**, plenum member **33** has been moved to an everted position by the pressure of compressed gas or air introduced between midsole **20** and plenum membrane **30** through tubing **60**, connected to pump means **42**. In the everted position of FIGS. **5B**

and **3B**, a plenum cavity **34** is created, which is maintained in the expanded position by being filled with compressed air from pump means **42**.

[0048] Plenum member **33** functionally resembles what is known as a "dome spring." However, plenum member **33** has a more complex shape than a simple dome to allow it to fit tightly around ferrule **80** and also adapt plenum member **33** to move spike assembly **70** a longer downward distance than a simple dome would allow. When plenum member **33** moves from its contracted to its everted position, plenum member **33** "pops" from contracted to everted position without significant stretching of any portion of plenum member **33**. In the everted position, the walls of plenum member **33** are supported by the shaped walls of aperture **94** and by rigid ferrule **80** so as to protect plenum member **33** against over-expansion. The shape of plenum member **33** and support from aperture **94** and ferrule **80** cooperate to provide a movement mechanism for spike assemblies **70** that is very durable and robust.

[0049] FIGS. **3A** and **3B** show midsole **20** as including cut-out portion **24** to accept each plenum member **33** in its contracted position and to form part of the volume of plenum cavity **34** when plenum member **33** is everted. This is a preferred embodiment of the present invention, but alternative designs are possible and will be obvious to those with skill in the art.

[0050] To assemble sole assembly **10**, midsole **20** is attached to an appropriate shoe upper (not shown) as is well known. The shoe upper may be of a sort suitable for wearing while playing sports, including golf or soccer, or may be of a sort suitable to wear hiking on loose soil or mud, or for walking on snow or ice.

[0051] Front plenum membrane, with attached ferrules **80**, is placed over front portion **91** of outsole **90** such that ferrules **80** each nest into an aperture **94**. The components of pneumatic system **40** are placed in their respective cut-outs in outsole **90**. As shown in FIG. **2**, sections of tubing **60**, such as flexible tubing of durable synthetic rubber, are used to connect the components. Tubing **60** includes an intake tube **61**, supply tube **62**; outlet tube **63**, and heel tube **64**.

[0052] Supply tube **62** connects the plenum members **33** in series to pump means **42** via switch valve **55**. Plenum members may be connected to each other by small sections of tubing **60**, or by air channels **22** cut into the bottom surface of midsole **20** as shown in FIG. **6**. Heel tube **64** passes through a borehole **96** through outsole **90** to supply compressed gas to heel subsystem **43**. Spike assemblies **70** are typically disposed in the front and heel portions of the sole assembly only, because arch portion **93** does not bear much weight of the wearer.

[0053] After the upper portion of pneumatic system **40** is assembled on the top surface of outsole **90** and heel tube **64** is inserted into borehole **96**, midsole **20** and outsole **90** are attached together with plenum membrane **30** between them. Typically, suitable adhesive is spread over the flat (non-cut-out) upper surfaces of outsole **90** and the complimentary surfaces of the bottom of midsole **20**. Then midsole **20** and outsole **90** are pressed together, optionally in a mold, so as to create a gas-tight bond among outsole **90**, midsole **20**, and plenum membrane **30**.

[0054] In similar manner, heel pneumatic subsystem **43** is assembled on the bottom of outsole **90** and outsole **90** and shoe heel **95** are glued together with heel membrane **32** sandwiched between them. Heel tube **64** connects the plenum



members 33 in series to pump means 42 so as to activate spike assemblies 70 located in heel 95.

[0055] Because air channel 24 will not function efficiently if partially obstructed by adhesive, the adhesive applied between midsole 20 and outsole 90, and between outsole 90 and heel 95, is preferably metered and located precisely. This may be done by use of a sheet of preformed solid adhesive, by screen printing the adhesive, by offset printing, by machine-controlled syringe dispensing, or similar technique as is well known.

[0056] Finally, spike bodies 71 are connected to ferrules 80 by screwing connectors 74 into threaded holes 81. Optionally, a tool (not shown) with prongs adapted to fit into engagement holes 73 may be used to rotate spike body 71.

[0057] As the wearer walks, bladder 41 is alternately compressed and released. When bladder 41 is released, bladder 41 fills to its natural expanded state by drawing air through inlet tubing 61 and check valve 51. When bladder 41 is compressed, the air is prevented by check valve 51A from returning through inlet tube 61, so the air is forced onward from bladder 41 into pressure reservoir 45 via check valve 51B.

[0058] The air then flows to switch valve 55, which includes a switch, such as pushbutton 58, or a toggle switch, rocker switch, or other suitable switch means. Switch valve 55 can direct air received from reservoir 45 either to supply tube 62 or to outlet tube 61, as selected by the wearer using pushbutton 58.

[0059] If "relief" mode is selected, a small amount of air is drawn into inlet tube 61 and released from outlet tube 63 with each step. The pressure of this circulating air is not enough to evert plenum members 33 and extend spike tips 76 against the weight of the wearer.

[0060] To activate spike assemblies 70 to increase the traction of the shoe during wearing, switch valve 55 is set to retain pressure within pneumatic system 40. Pushbutton 58 may be manipulated by hand, by tapping it with a golf club or hiking stick, or by tapping the heel of one shoe against the switch 28 of the other shoe. Only a single click is required to change switch valve 55 from "pressure" mode to relief mode, or vice versa.

[0061] With switch valve 55 in pressure mode, compressed air from reservoir 45 is directed through supply tube 62 to pressurize plenum members 33. The pressure is usually sufficient to evert plenum members 33 immediately and extend spike tips 76 substantially below outsole 90. Should there be insufficient pressure stored in reservoir 45, pump means 42 will add the additional pressure needed as the wearer takes the next few steps. Switch valve 55 maintains pneumatic system 40 closed so that spike tips 76 remain extended and support wearer's weight.

[0062] Check valves 51A, B are adapted to maintain pneumatic system 40 at a pre-determined pressure when pressure mode is selected. Check valves 51A, B prevent backflow of compressed air until the target pressure is reached. After that, check valves 51A, B will allow excess air to escape, in order to prevent undue stress on pneumatic system 40 and to maintain a comfortable flexibility and softness of sole assembly 10 for walking.

[0063] Depending upon the intended use for a shoe with the sole assembly 10 of the present invention, the bottom surface of outsole 90 may be generally smooth. In this case, it may be preferable that spike body 71 be dimensioned such that tip 76 is flush with the bottom surface of outsole 90 or retracts to be slightly above the bottom of outsole 90.

[0064] Alternatively, outsole 90 may have permanent tread features such as ripples, ridges, or other texture pattern. In this case, it may be desirable that spike body 71 retract only sufficiently that tip 96 protrudes slightly from outsole 90 in the retracted position. Many design choices may be made while enjoying the advantages of the present invention.

[0065] Turning now to FIGS. 7 and 8, an alternative preferred embodiment of the invention is illustrated. FIG. 7 is a top perspective view of the outsole portion of a second preferred embodiment of the sole assembly of the present invention. Apertures 94 are adapted to receive plenum chambers 34 as previously described, but not shown in FIG. 7.

[0066] Sole assembly 10B of Figure differs from sole assembly 10A in three main ways. Sole assembly 10B does not include reservoir 45; supply tubing 62 connects apertures 94 for plenum chambers 34 in parallel rather than in series; and apertures 94 are shaped to receive discrete plenum assemblies 50 rather than a plenum membrane 30. Additionally, heel pneumatic sub-system 43 is not shown, but may optionally be included.

[0067] It has been found that reservoir 45 is not needed in all applications. The purpose of reservoir 45 is to retain a quantity of compressed air to extend spike assemblies 70 nearly instantaneously on demand. However, depending upon the number of spike assemblies and the total volume of all plenum chambers 34 relative to the volume of bladder 41, spike assemblies 70 may be fully extended and firm with only two or three steps by the wearer. In this case, reservoir 45 may be omitted if desired. If reservoir 45 is omitted, switch valve 55 and associated tubing 60 is rearranged as appropriate.

[0068] Sole assembly 10B has supply tubing 62 arranged in a "tree" configuration to actuate spike assemblies 70 in parallel. This configuration is found to pressurize quickly and reliably, especially if the pressurized air is conducted by cylindrical tubing 62 that is laid into channels 24 instead of being conducted by channels 24 themselves, as described above. The use of separate tubing instead of channels 24 to conduct pressurized air may make for a more complex and expensive sole assembly 10B, yet simplifies the gluing operation and may result in a more robust product.

[0069] Each plenum assembly 50 that is supplied by tubing 62 in the tree configuration may optionally be provided with an individual check valve, not shown, to help maintain spike assemblies 70 in an extended position even if one spike assembly 70 should develop a small leak.

[0070] FIGS. 8A and 8B are cross-sectional views showing an alternative preferred embodiment of plenum assemblies 50 and spike assemblies 70B in retracted and extended positions, respectively. Plenum assembly 50 is a discrete unit that is installed into aperture 94. Plenum assembly 50 generally includes chamber cylinder 36, which is a cylinder with one closed end, made for example from a thermoplastic material. Chamber cylinder 36 typically has 2-2.7 cm inside diameter and 1-1.5 cm inside height. Chamber cylinder 36 includes an aperture such as air port 37 that receives supply tubing 62 for pressurizing plenum chamber 34B. Chamber cylinder 36 includes a wall cylinder 53 and top surface 54.

[0071] In the embodiment shown in FIGS. 8A and 8B, plenum membrane 33B is a discrete "dome spring" that fits snugly into the open end of chamber cylinder 36. Embedded within plenum membrane 33B is a rigid ferrule 80, such as of metal, that includes a threaded hole 81 for receiving spike body 71. Ferrule 80 is typically embedded in plenum membrane 33B by a co-molding process or may be attached such

as by adhesive. Spike body **71** is rigid, such as of metal or strong plastic, and includes threaded connector **74** for connection to threaded hole **81** and tool eyelet **77** for accepting a slender tool to facilitate rotation of spike body **71** in threaded hole **81** for installation or removal.

[0072] Cover plate **35** covers the bottom of plenum membrane **33B**. Cover plate **35** is generally a disk with a central spike aperture **38** through which spike shaft **75** protrudes. Cover plate **35** and chamber cylinder **36** typically include reliefs or flanges as needed to help plenum membrane **33B** seat securely between cover plate **35** and chamber cylinder **36**. As shown in FIGS. **8A** and **8B**, cover plate **35** also includes centering guide **39**. Centering guide **39** is a stiff ring around central hole **38** that causes spike shaft **75** to extend perfectly normal to cover plate **35** even under the weight of the wearer. Centering guide **39** further stiffens cover plate **35** so that cover plate **35** does not deflect when plenum chamber **34B** is pressurized.

[0073] To assemble plenum assembly **50**, chamber cylinder **36**, plenum membrane **33B** with embedded ferrule **80**, and cover plate **35** are assembled together as shown in FIGS. **8A** and **8B**, such as by co-molding or adhesive.

[0074] A plurality of plenum assemblies **50** are inserted into apertures **94** of outsole **91**. Supply tubing **62** is connected to each air port **37** so that each plenum chamber **34B** is in communication with switch valve **55** for receiving pressurized air from bladder **41**. Pump means **42** actuates extension and retraction of spike bodies **71** as described above.

[0075] Sole assembly **10B** may be attached to any suitable shoe midsole and upper, not shown. The midsole should preferably be of sufficient thickness to accommodate plenum assemblies **50** so that the wearer feels no discomfort from plenum assemblies **50**. Optionally, an additional, easily removable cover sole (not shown) with small spike holes may be attached under outsole **91**. Cover sole may be stripped away after the shoe is worn to easily remove built up mud or other debris.

[0076] Spike shafts **75** are shown in FIGS. **8A** and **8B** as slender and pointed. If spike shaft **75** should become damaged or blunted, spike shaft **75** is conveniently replaced by inserting a slender tool, such as a small nail, through eyelet **77** and using the tool to rotate spike shaft **75** until threaded connector **74** is released from threaded hole **81**. A fresh spike shaft **75** is then installed in similar manner.

[0077] In yet a third envisioned embodiment of the invention, a spike module **100** can be created separately from the manufacture of a shoe. Spike module **100** generally comprises plenum assembly **50** of FIGS. **8A** and **8B**, including spike assembly **70**. Spike module **100** can be installed within a suitable shoe by a second party and connected to any suitable source of pressurized fluid such as carbon dioxide, water, propylene glycol, or compressed air.

[0078] Although particular embodiments of the invention have been illustrated and described, various changes may be made in the form, composition, construction, and arrangement of the parts herein without sacrificing any of its advantages. Therefore, it is to be understood that all matter herein is to be interpreted as illustrative and not in any limiting sense, and it is intended to cover in the appended claims such modifications as come within the true spirit and scope of the invention

What is claimed is:

1. A sole assembly for a shoe having an upper portion, including:
  - a sole body, including:
    - a midsole for attachment to the upper portion of the shoe; and
    - an outsole attached to the bottom of said midsole for providing a walking surface with variable traction; including:
      - a plurality of apertures through said outsole;
  - a plurality of spike assemblies, each movable between a retracted position substantially within said sole body and an extended position wherein a portion of said spike assembly protrudes from its said aperture so as to increase the traction of said outsole upon the ground; and
  - a pneumatic assembly for providing pressurized air for selectively moving said plurality of spike assemblies from retracted to extended position; including:
    - selection means movable between a first position for selecting retracted position of said spike assemblies and a second position for selecting extended position of said spike assemblies; and
    - pump means powered by the wearer's walking, for providing the pressurized air for moving said spike assemblies from retracted to extended position when said selection means is in the second position.
2. The sole assembly of claim 1, wherein said pump means comprises:
  - a pump powered by the wearer's walking, for compressing and storing ambient atmosphere; and
  - means for conducting compressed air from said pump to said plurality of spike assemblies.
3. The sole assembly of claim 2, said pump comprising:
  - a compression body, including:
    - an inlet for ambient air; and
    - an outlet for compressed air;
  - a one-way flow valve connected between said compression body and said spike assemblies, for preventing compressed air from returning from said spike assemblies to said compression body; and
  - a one-way flow valve connected between said compression body and said inlet for ambient air, for preventing compressed air from returning from said compression body into the atmosphere.
4. The sole assembly of claim 1, said pneumatic assembly further including:
  - a resilient plenum membrane attached between said midsole and said outsole; such that a plurality of portions of said plenum membrane are disposed above said apertures of said outsole; said portions adapted for expanding downwardly into said apertures upon activation by compressed air supplied by said pump means; said portions of plenum membrane exerting a downward force on said spike assemblies when expanded so as to move said spike assemblies from retracted to extended position.
5. The sole assembly of claim 1, said pneumatic assembly further including:
  - a plurality of plenum members disposed between said midsole and said outsole and in pneumatic communication with said pump means; each said plenum member attached above one said spike assembly such that each said plenum member moves from a contracted position

to an everted position activated by compressed air; so as to move said spike assembly between retracted and extended positions.

6. The sole assembly of claim 2, said pneumatic assembly further including:

- a plurality of plenum assemblies; including:
  - a chamber cylinder; including:
    - an air port connected to said means for conducting compressed air;
  - a cover plate covering the bottom of said chamber cylinder such that said chamber cylinder and said cover plate cooperate to define an enclosed volume;
- said cover plate including:
  - a spike aperture; and
  - a plenum membrane dividing said enclosed volume horizontally into an upper plenum chamber for receiving compressed air via said air port; and a lower chamber; and wherein each said plenum membrane is attached to a spike assembly; said spike assembly including:
    - a spike shaft connected to said membrane; including:
      - a spike tip disposed near said spike aperture; and wherein:

introduction of compressed air into said plenum chamber causes said plenum membrane to flex and cause said spike tip to be extended and maintained firmly until pressure is released.

7. A sole assembly for a shoe having an upper portion, including:

- a sole body for attachment to the upper of the shoe for providing a walking surface with selectively variable traction; said sole body including:
  - a plurality of apertures, recessed into the bottom face of said sole body;
- a plurality of spike assemblies disposed substantially within said plurality of apertures; each said spike assembly including:
  - a spike tip for increasing walking traction; said spike assemblies being disposed in said apertures such that each said spike assembly has a retracted position substantially within said sole body and an extended position with said spike tip extended below said sole body to provide increased traction; wherein the wearer's walking motion activates the movement of said spike assemblies between their retracted and extended positions.

8. The sole assembly of claim 7, each said spike assembly comprising:

- a ferrule permanently connected within said sole body; and
- a spike body removably connected to said ferrule such that said spike body can be removed and replaced without disassembling said sole body.

9. The sole assembly of claim 7, further including:

- a plurality of expansion chambers, disposed within said sole body such that each said expansion chamber is above one said spike assembly such that expansion of each said expansion chamber by compressed air will press downwardly on one said spike assembly so as to move said spike assembly from its retracted position to its extended position; the compressed air being created by the wearer's walking motion.

10. The sole assembly of claim 9, further sole assembly including:

- pump means for creating compressed air for expanding said expansion chambers; including:
  - a compression bladder alternately compressed and released by a wearer's footsteps;
- valve means for regulating the pressure of the compressed air;
- an intake for ambient air to flow into said bladder; and
- an outlet communicating with said expansion chambers for supplying compressed air from said compression bladder to said expansion chambers

11. A spike module for installing in a shoe for providing increased traction for the shoe on demand; said spike module activated by a source of pressurized fluid; comprising:

- a chamber cylinder for receiving pressurized fluid; including:
  - an inlet aperture connected to a source of pressurized fluid;
- a plenum membrane dividing said chamber horizontally into an upper plenum chamber for receiving pressurized fluid via said inlet aperture; and a lower chamber; said lower chamber including:
  - a spike aperture; and
- a spike assembly attached to said plenum membrane; including:
  - a spike shaft connected to said membrane; including:
    - a spike tip disposed near said spike aperture; and wherein:

introduction of pressurized fluid into said chamber causes said plenum membrane to flex and cause said spike tip to be extended through said spike aperture and maintained firmly until pressure is released.

12. The spike module of claim 11; said chamber further comprising:

- a cylinder;
- a top surface connected to said cylinder around the perimeter of said cylinder;
- a cover plate; including:
  - said spike aperture; said plenum membrane disposed between said cylinder and said cover plate and attached therebetween to form a fluid-tight seal.

\* \* \* \* \*