



US 20100105499A1

(19) **United States**
(12) **Patent Application Publication**
Roach et al.

(10) **Pub. No.: US 2010/0105499 A1**
(43) **Pub. Date: Apr. 29, 2010**

(54) **GOLF CLUB HEAD WITH MOVEABLE INSERT**

(75) Inventors: **Ryan L. Roach**, Carlsbad, CA (US); **Peter L. Soracco**, Carlsbad, CA (US)

of application No. 11/363,098, filed on Feb. 28, 2006, now Pat. No. 7,524,249, which is a continuation-in-part of application No. 11/110,733, filed on Apr. 21, 2005, now Pat. No. 7,658,686, which is a continuation-in-part of application No. 11/180,406, filed on Jul. 13, 2005, now Pat. No. 7,377,860.

Correspondence Address:
HANIFY & KING PROFESSIONAL CORPORATION
1055 Thomas Jefferson Street, NW, Suite 400
WASHINGTON, DC 20007 (US)

Publication Classification

(51) **Int. Cl.** *A63B 53/06* (2006.01)
(52) **U.S. Cl.** **473/335; 473/349**

(73) Assignee: **Acushnet Company**, Fairhaven, MA (US)

(21) Appl. No.: **12/581,975**

(22) Filed: **Oct. 20, 2009**

(57) **ABSTRACT**

The present invention is directed toward a golf club head with an adjustable insert. The insert is moveable in a face to back direction, and may be locked into place by one or more locking mechanisms. The insert may be adjustable so that the overall distance from the face to the back approaches the distance from the heel to the toe.

Related U.S. Application Data

(63) Continuation-in-part of application No. 12/076,322, filed on Mar. 17, 2008, which is a continuation-in-part

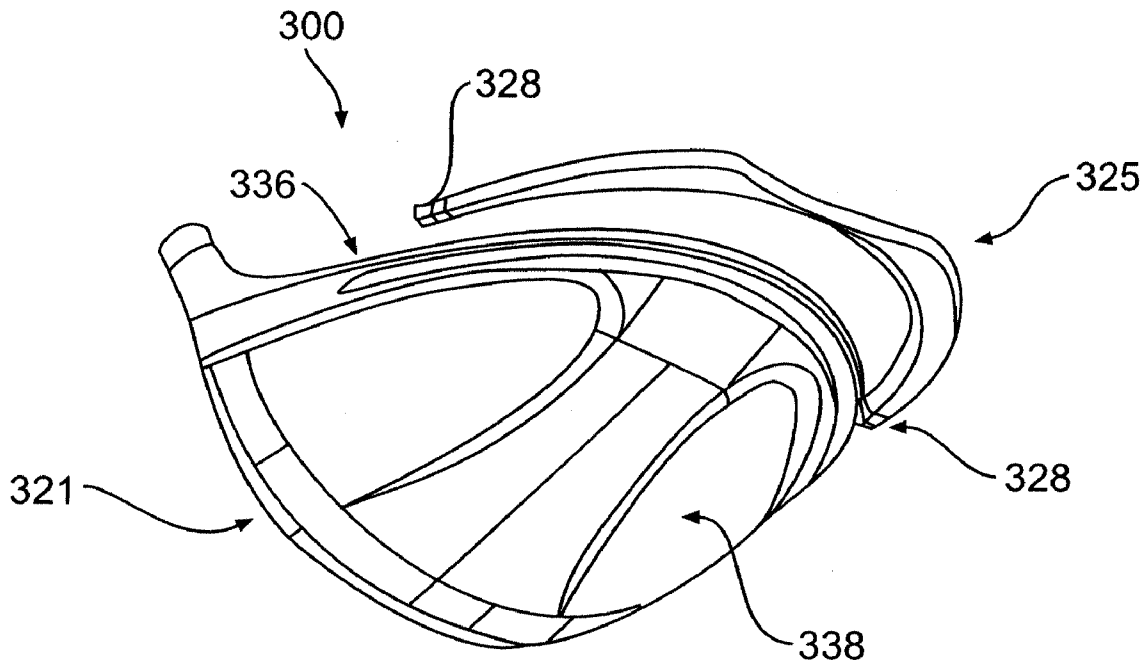

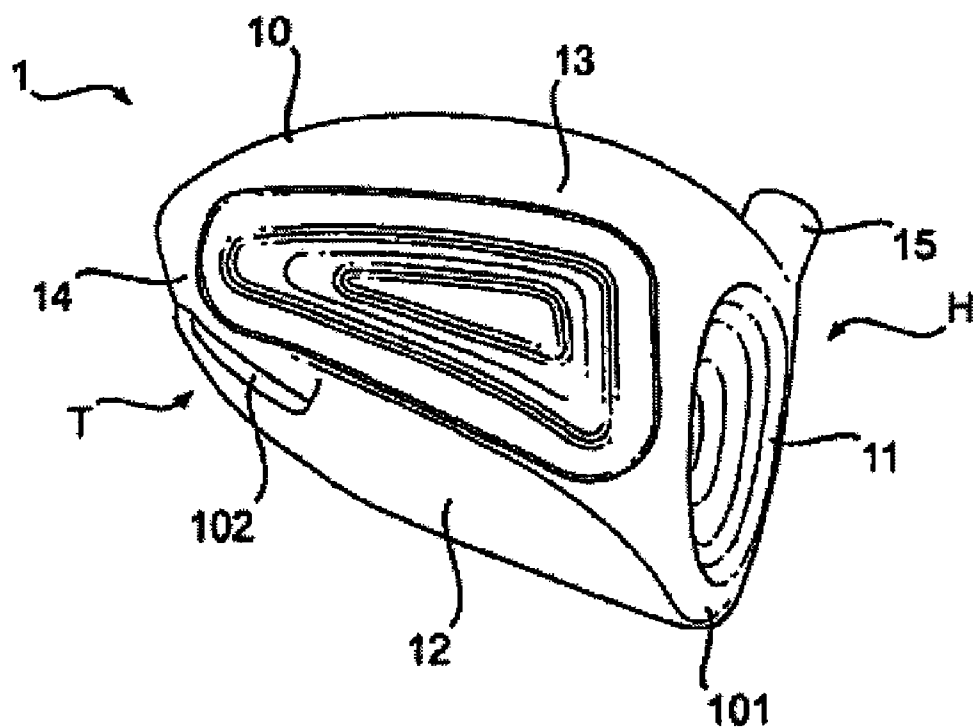

FIG. 1

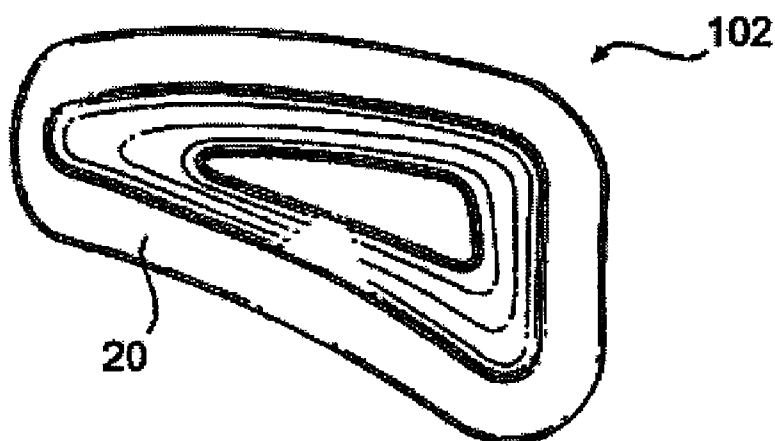

FIG. 2

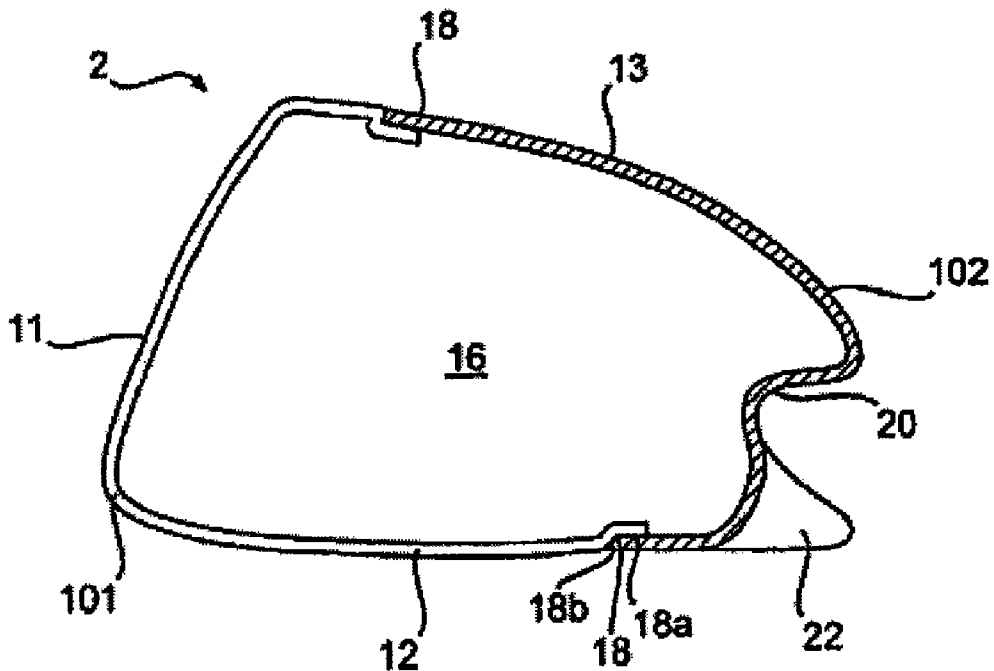

FIG. 3

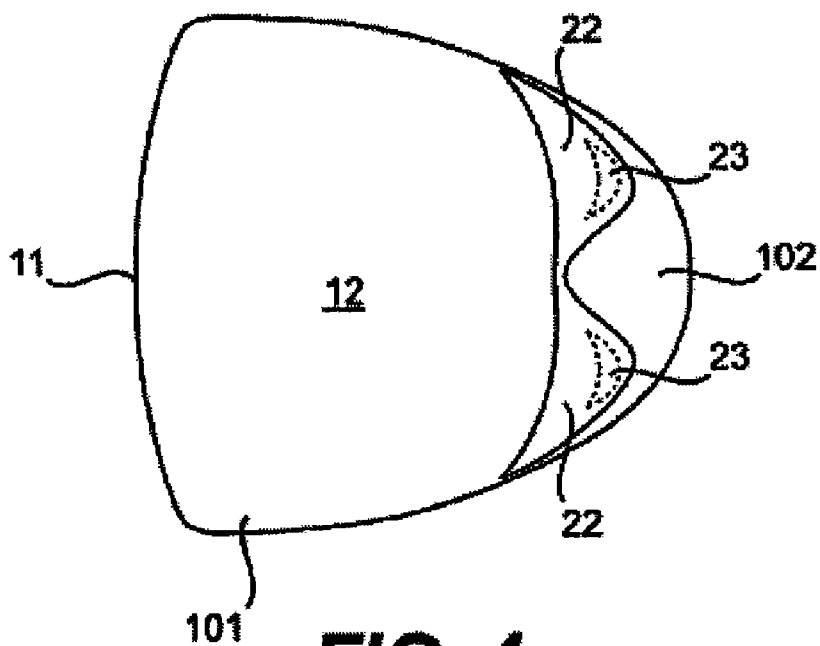

FIG. 4

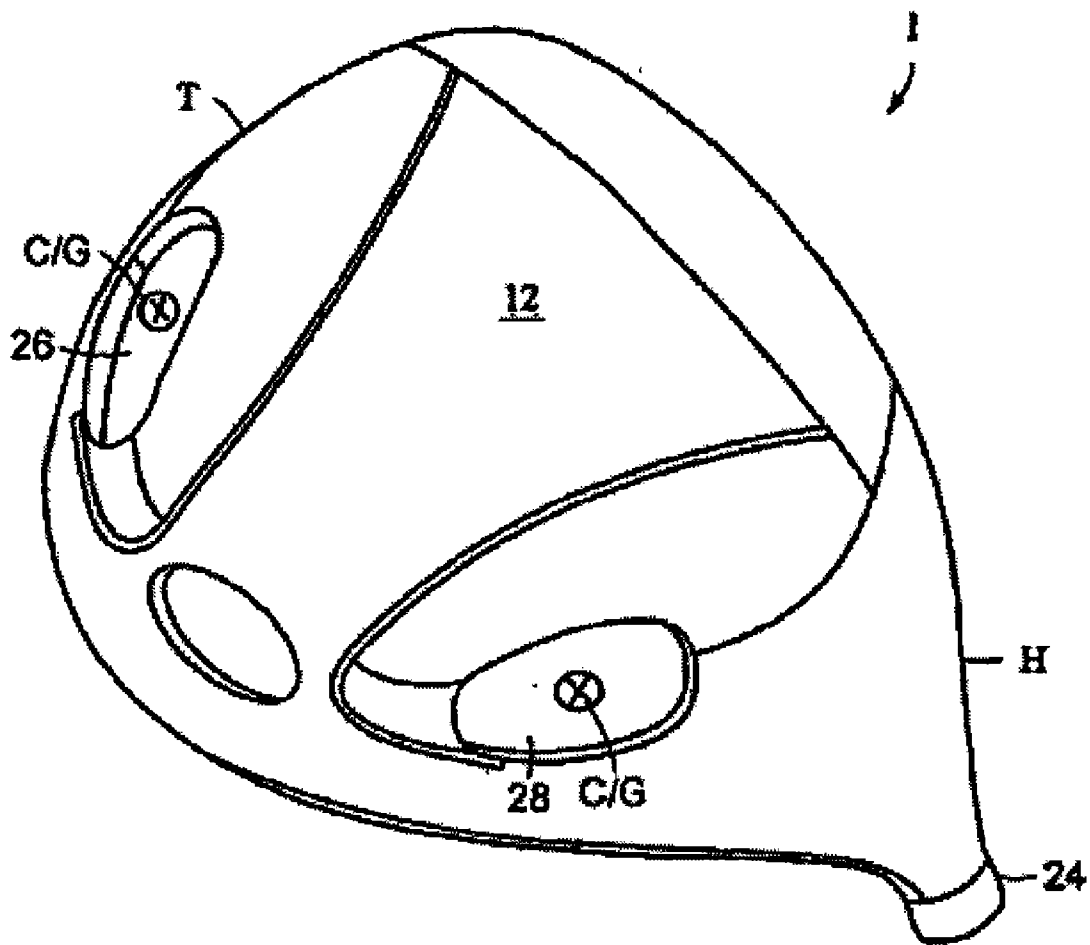

FIG. 5

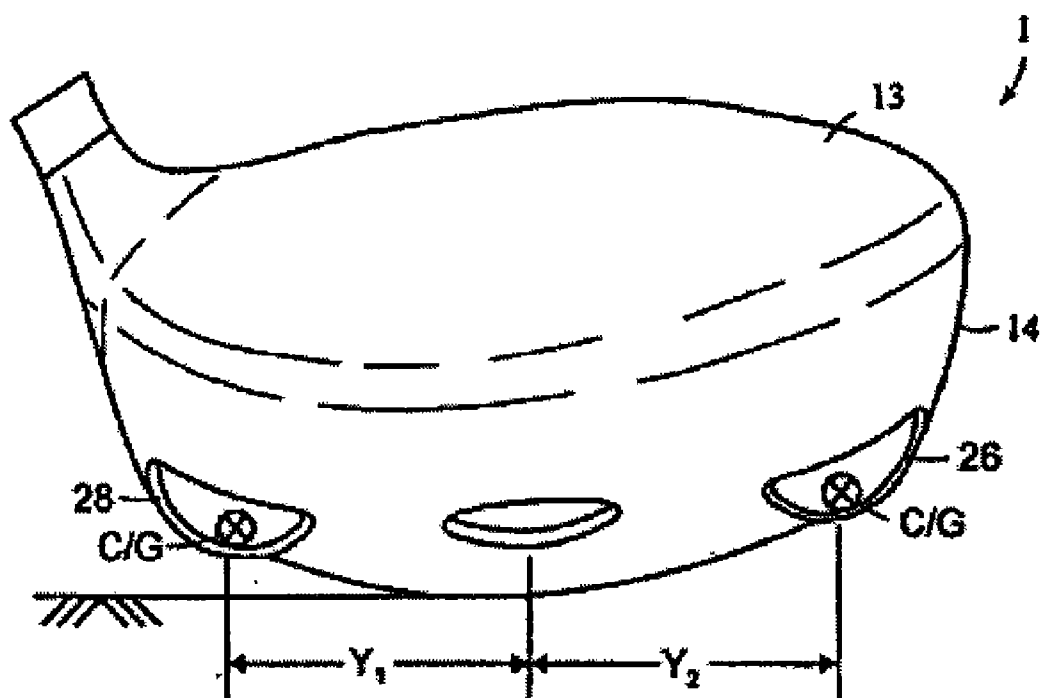

FIG. 6

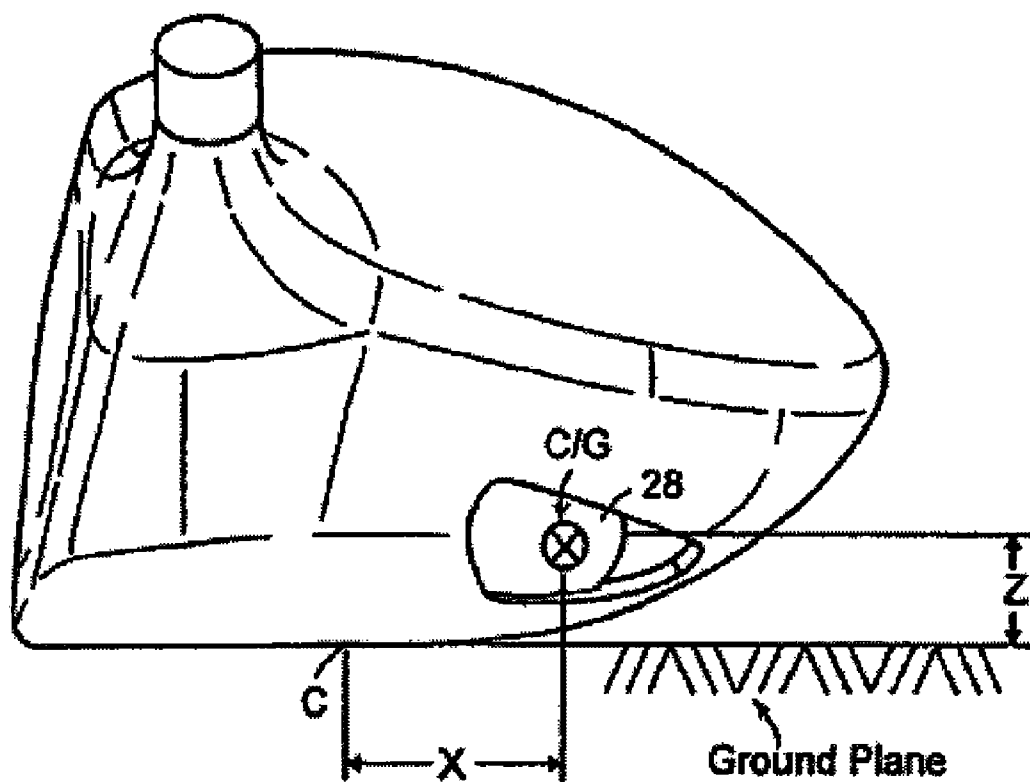

FIG. 7

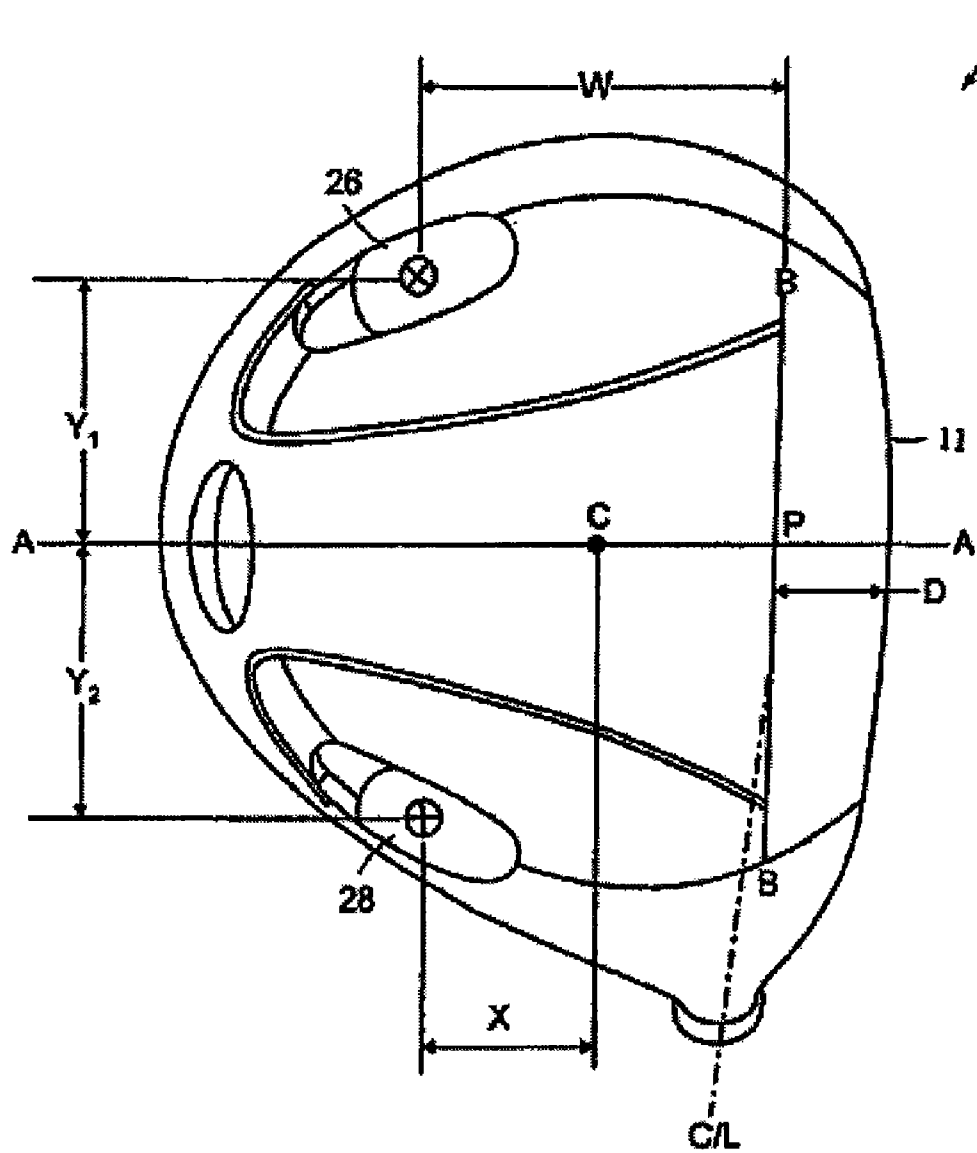

FIG. 8

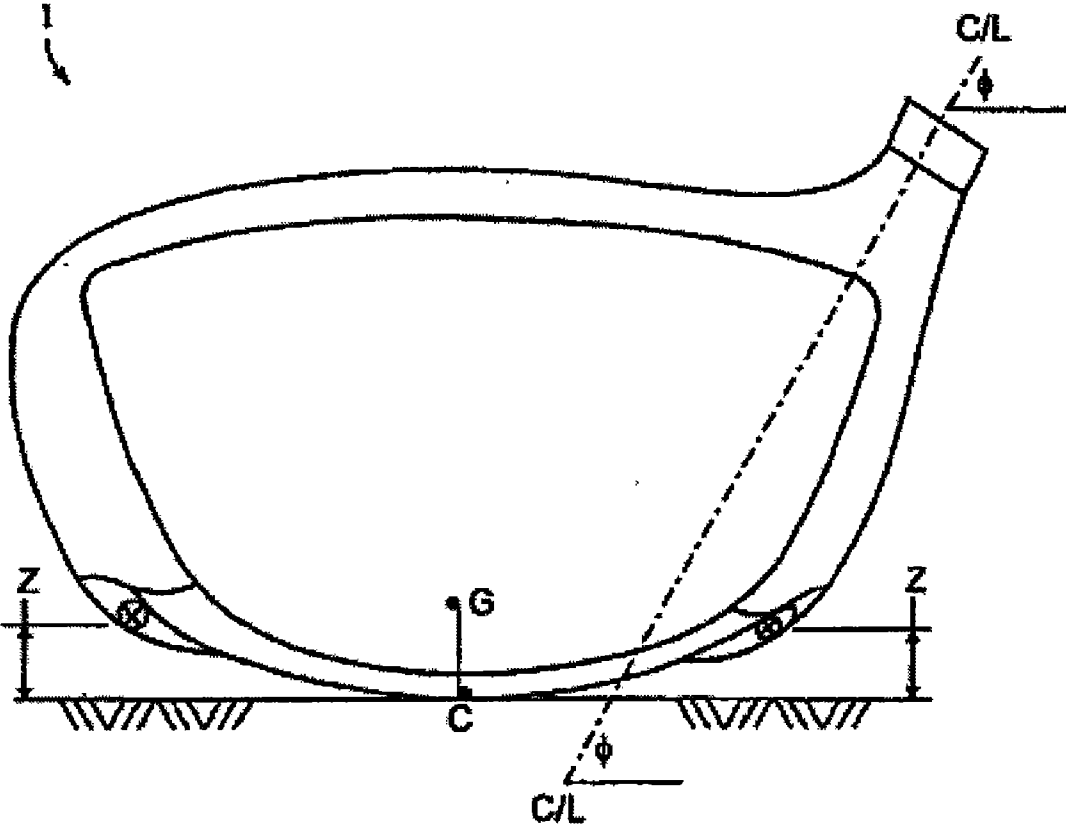

FIG. 9

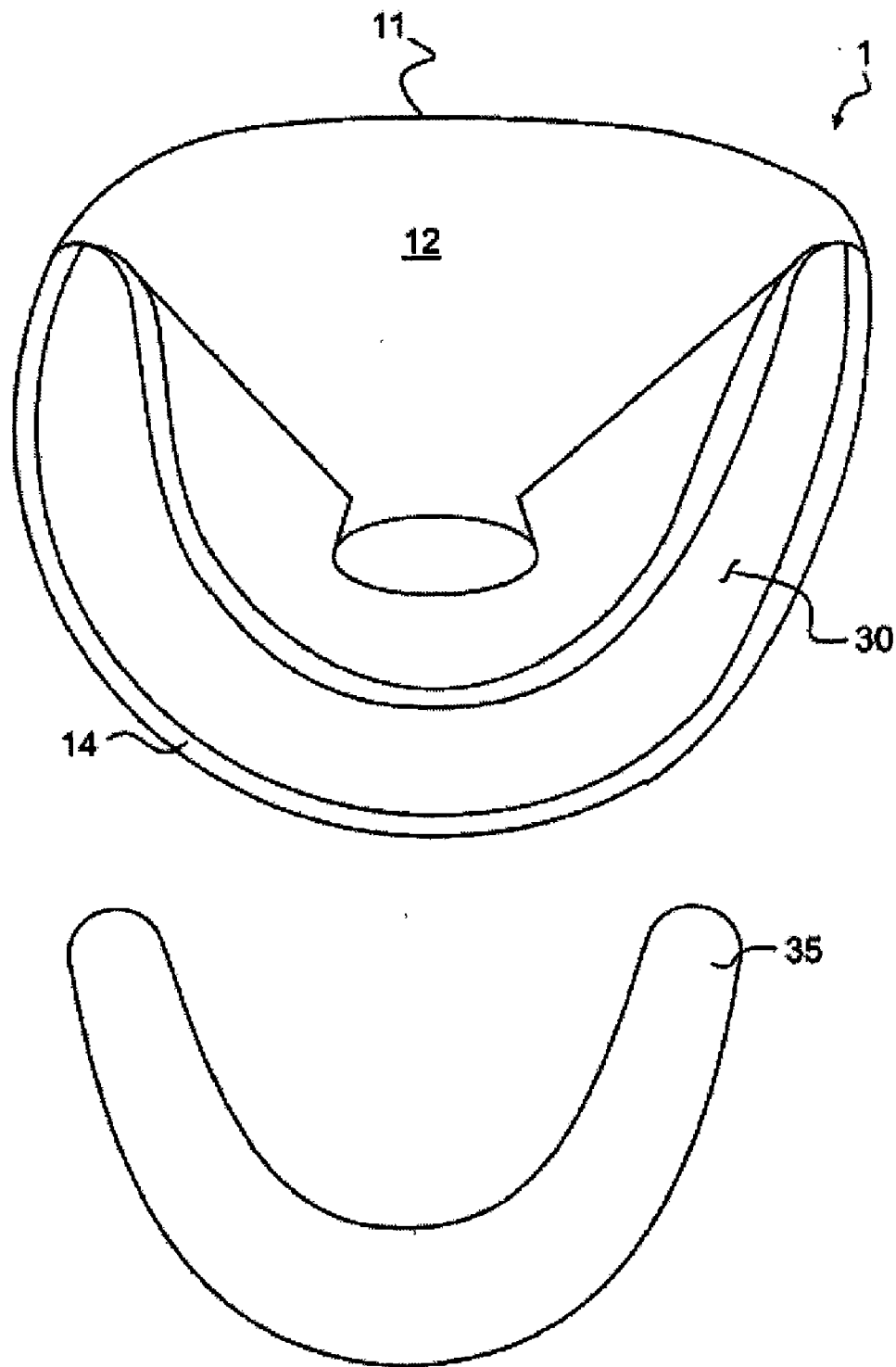

FIG. 10

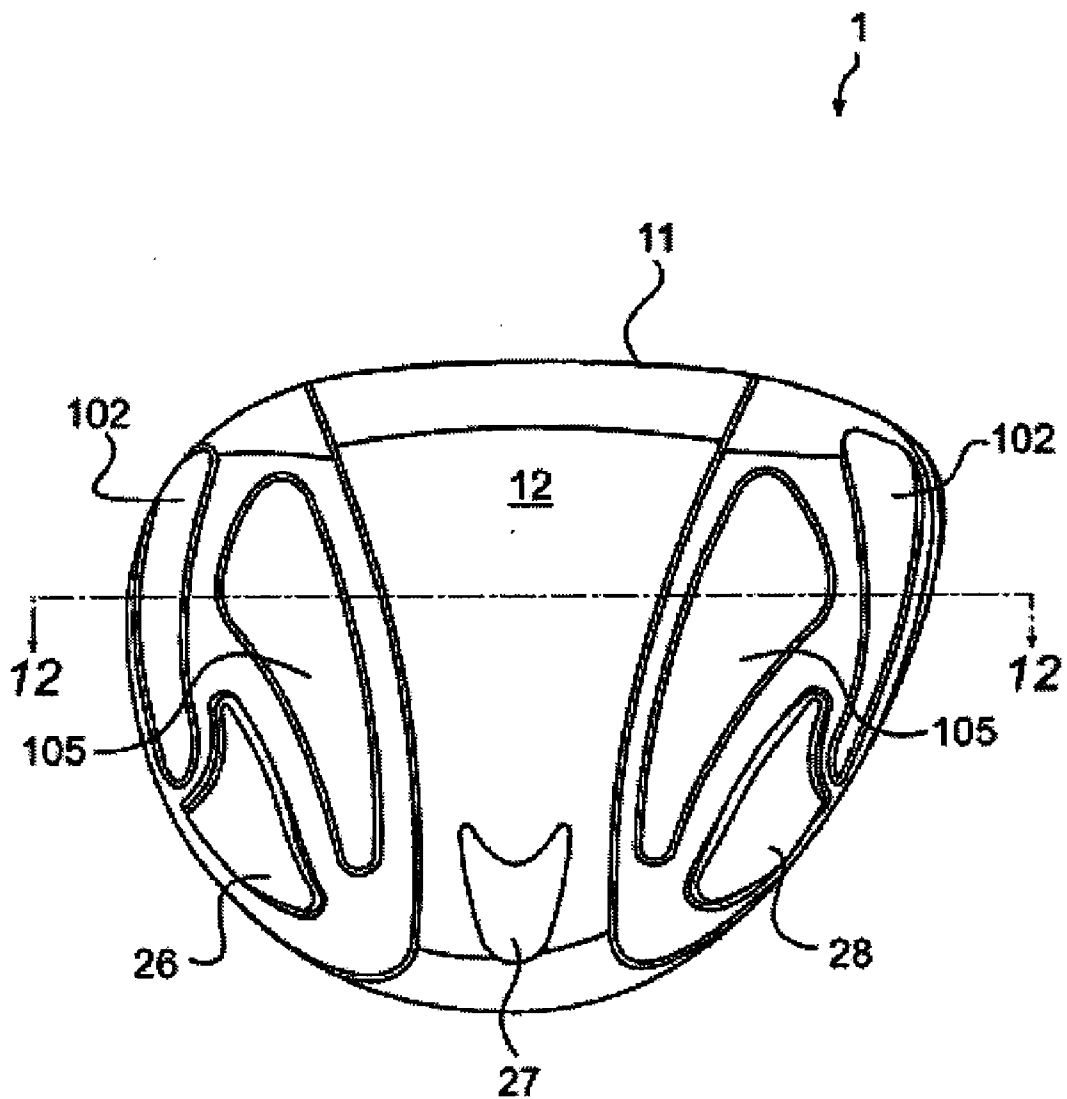

FIG. 11

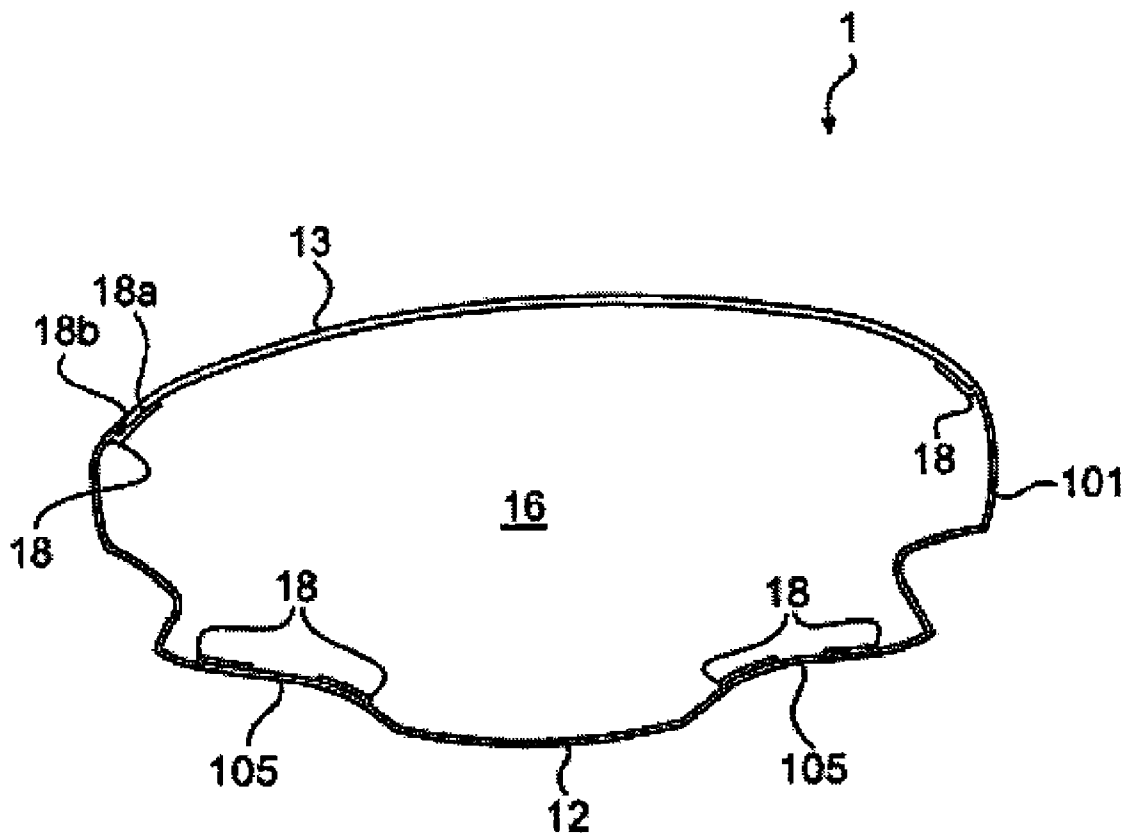

FIG. 12

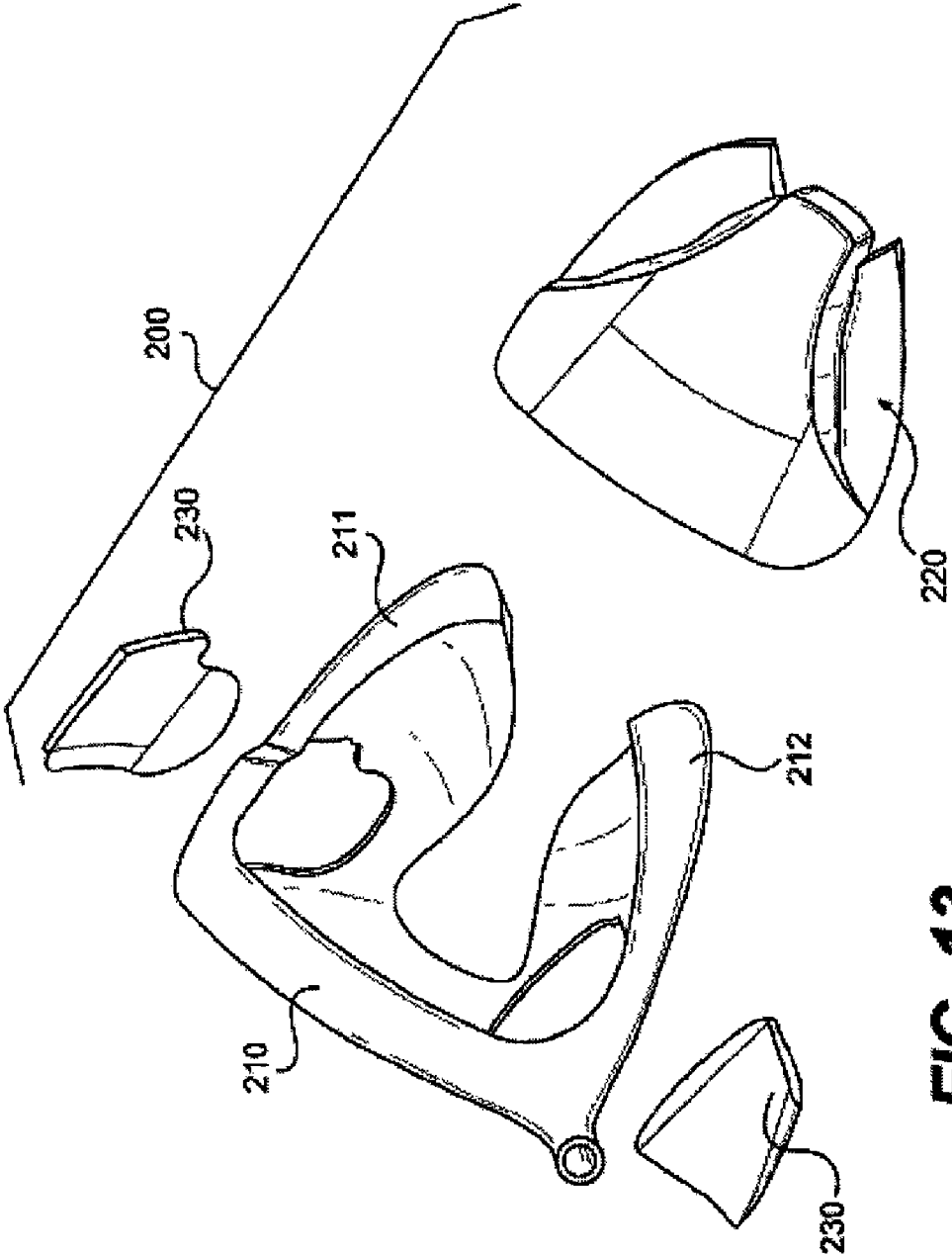

FIG. 13

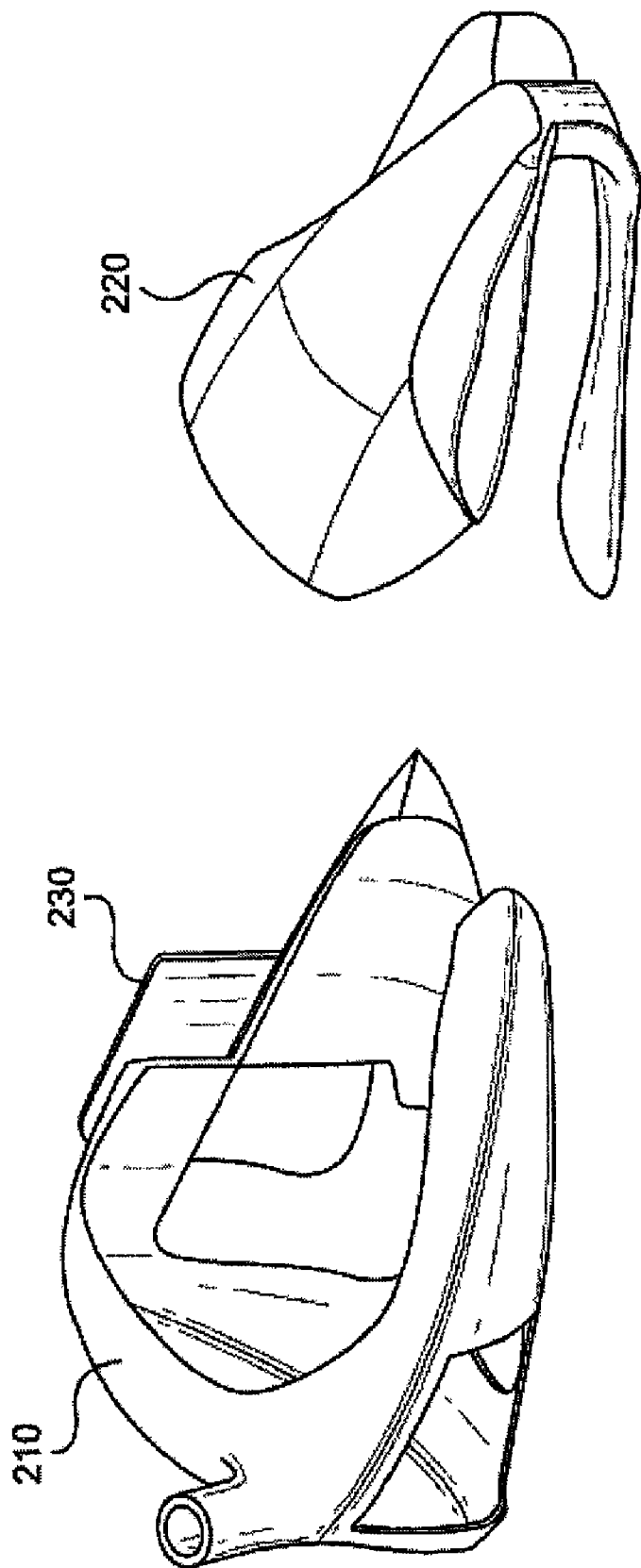

FIG. 14

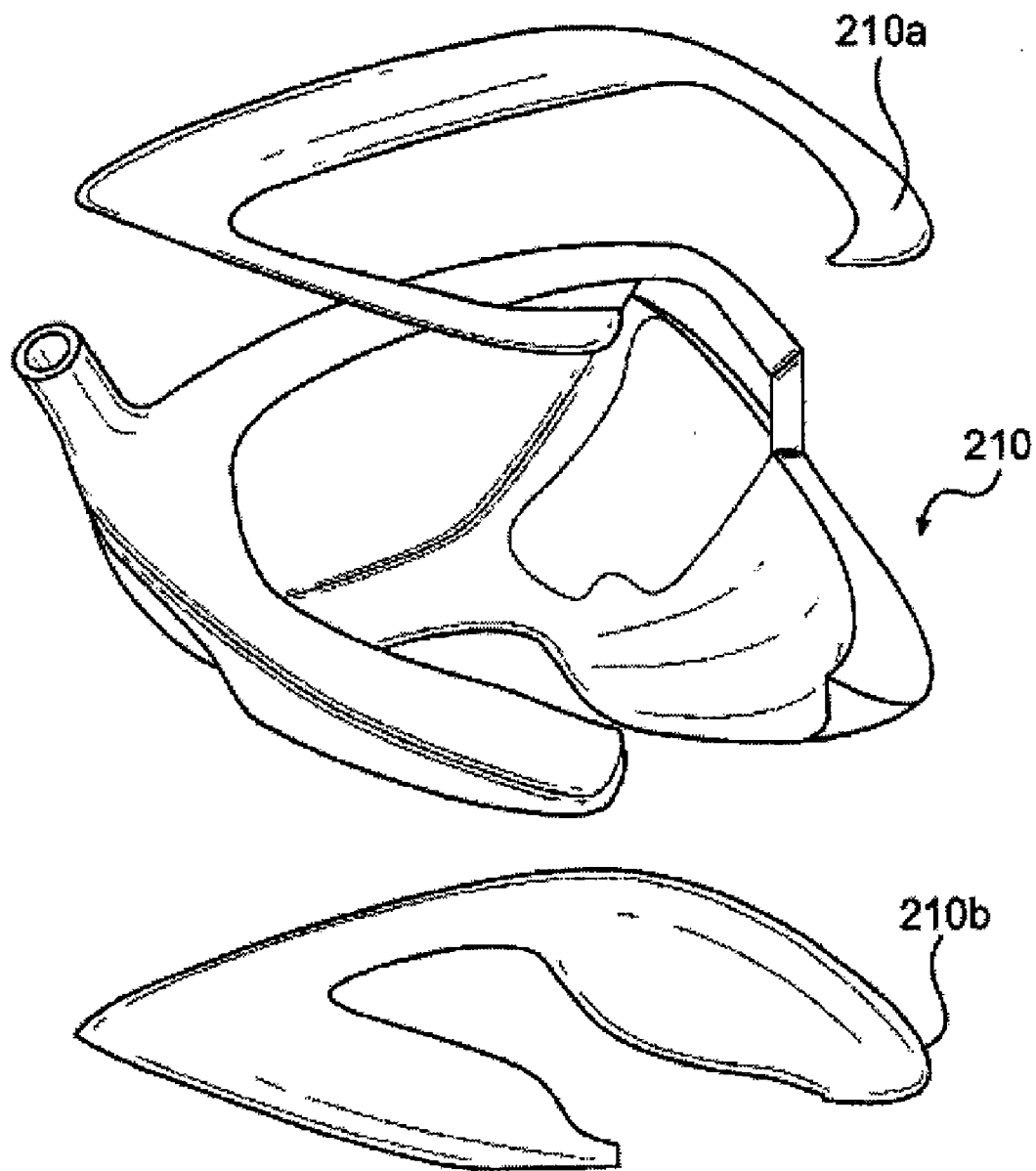

FIG. 15

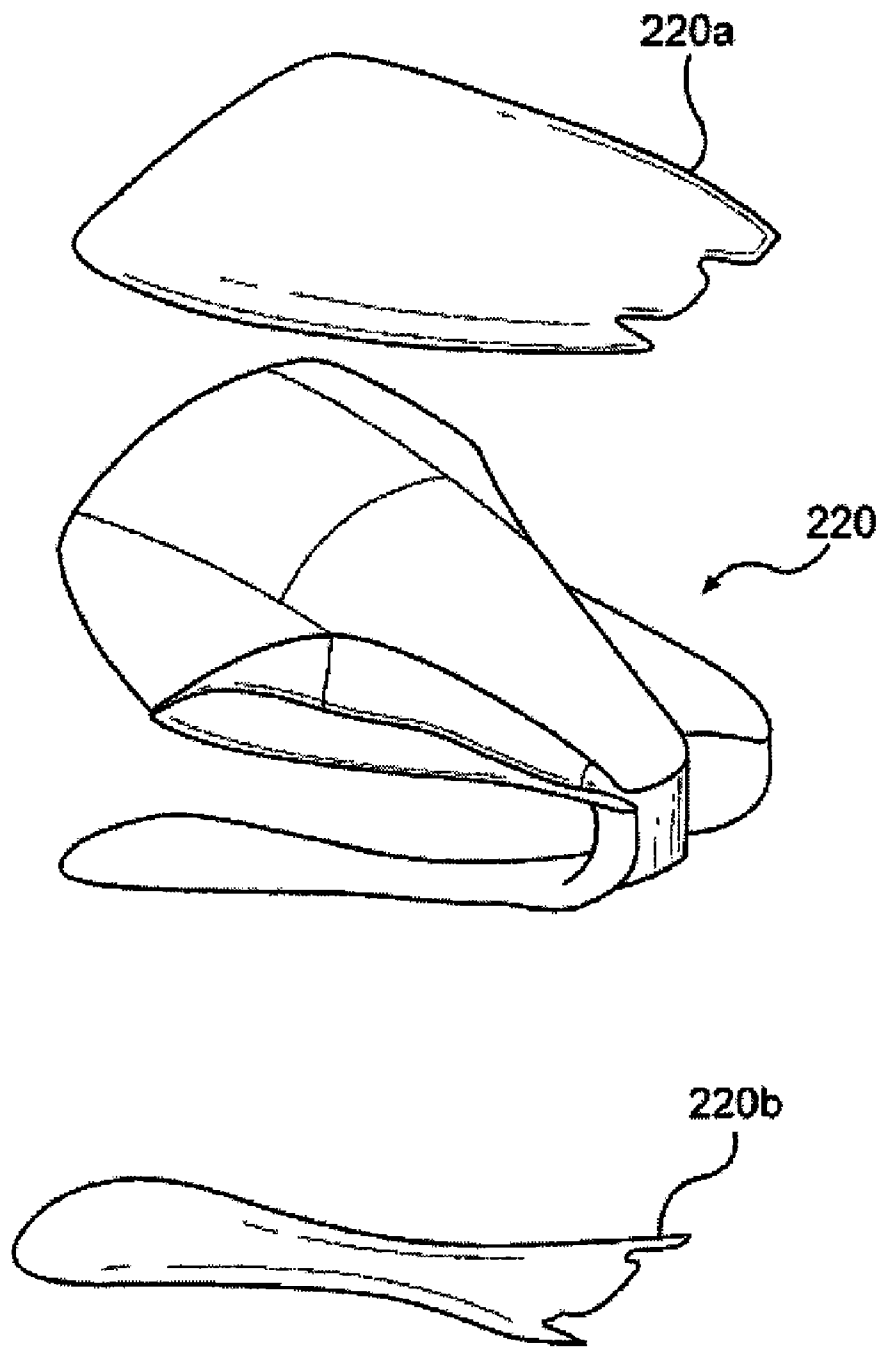

FIG. 16

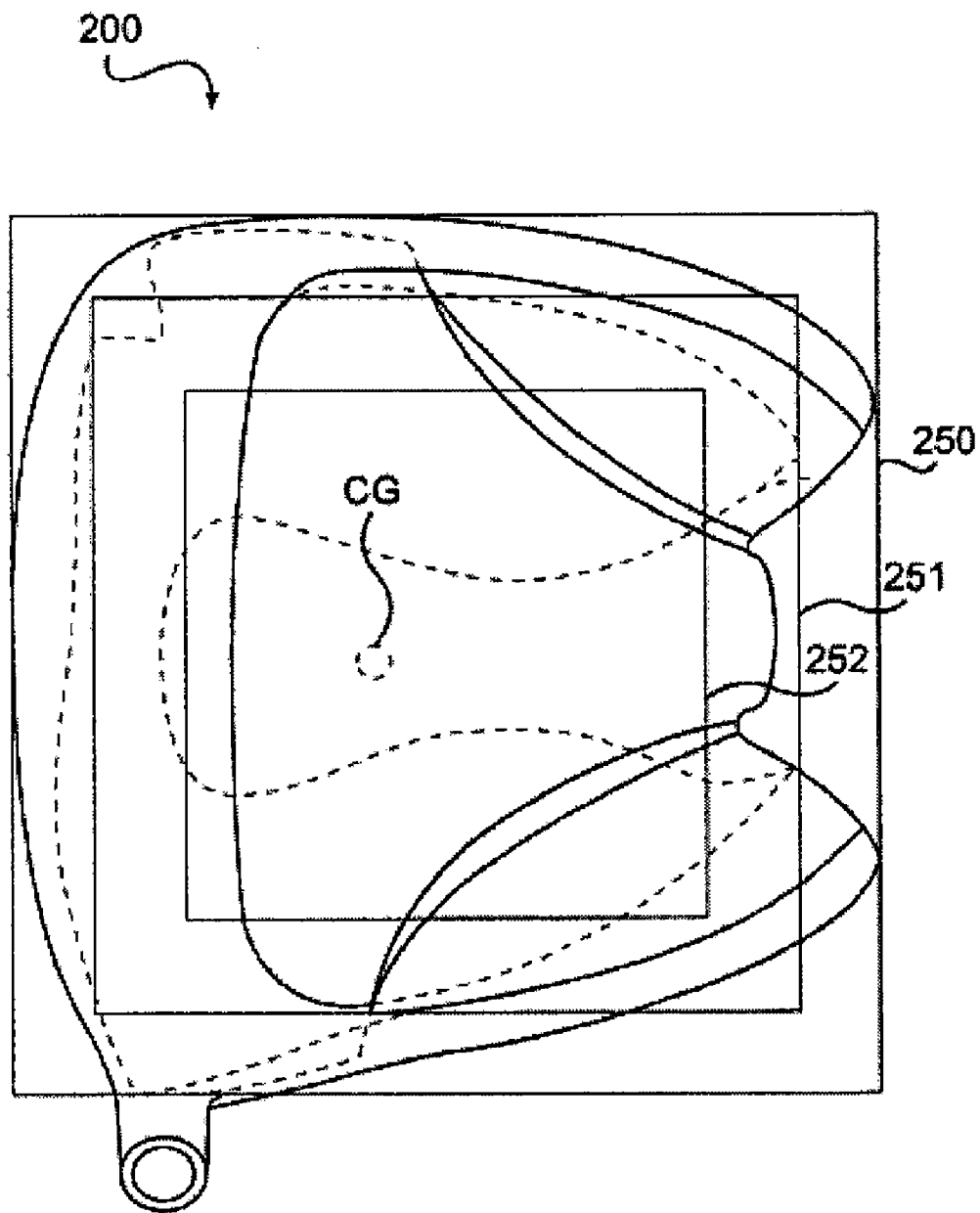

FIG. 17

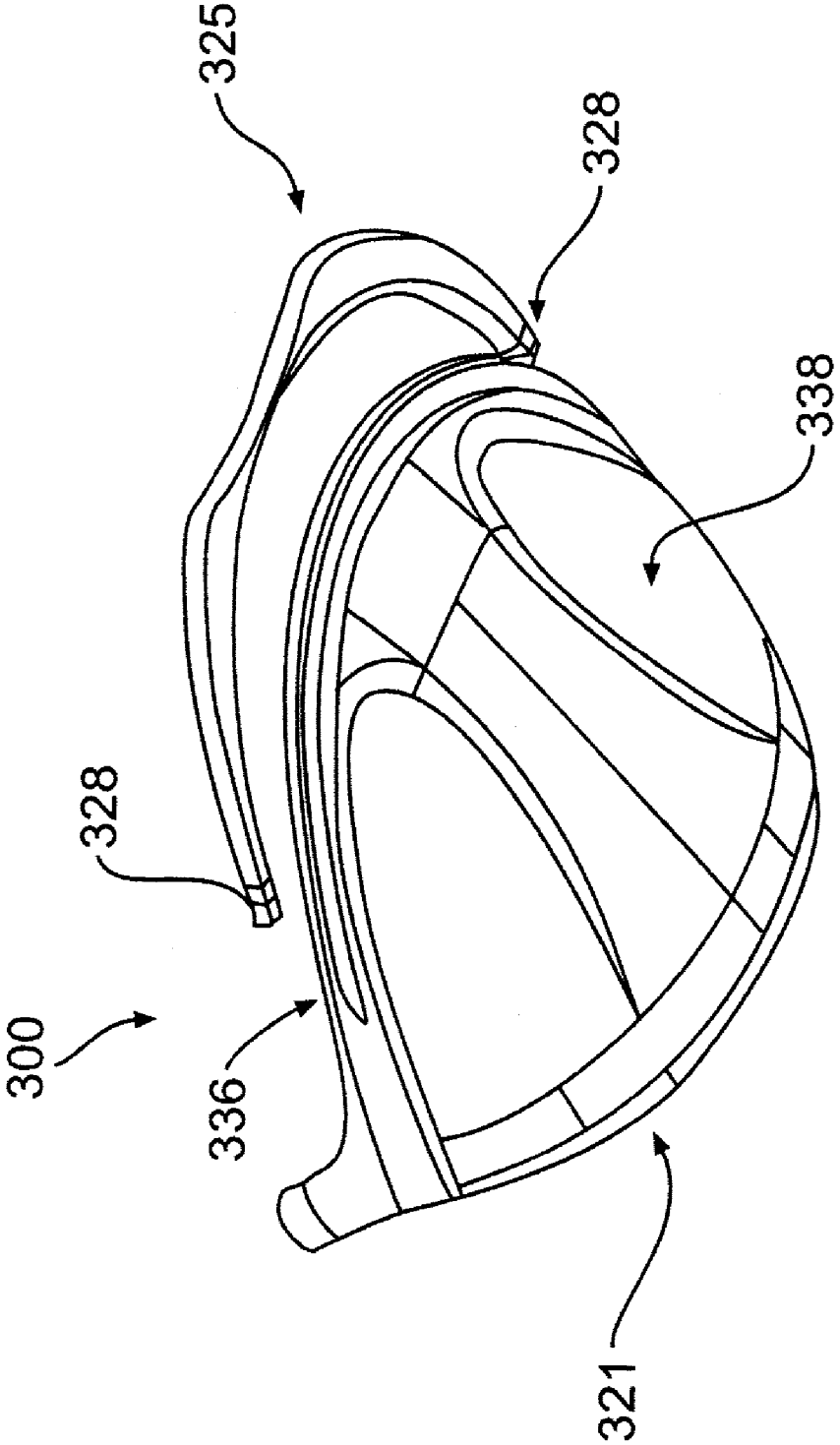

FIG. 18

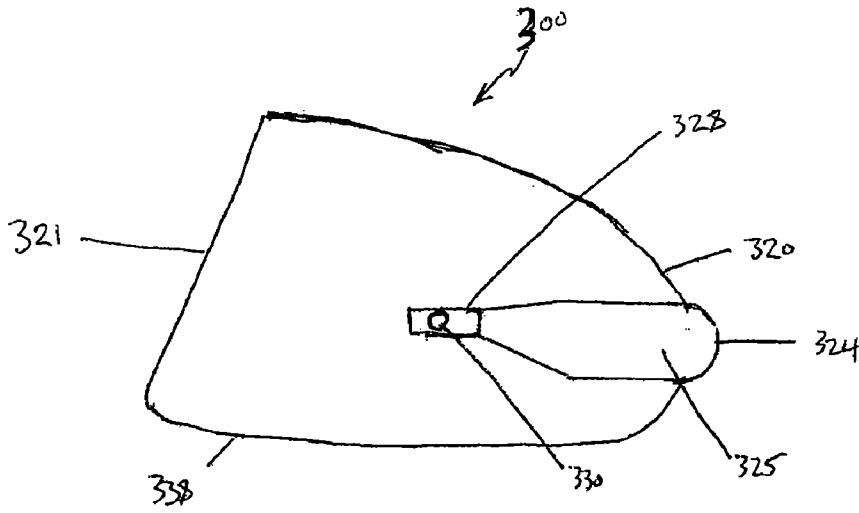

FIG. 19

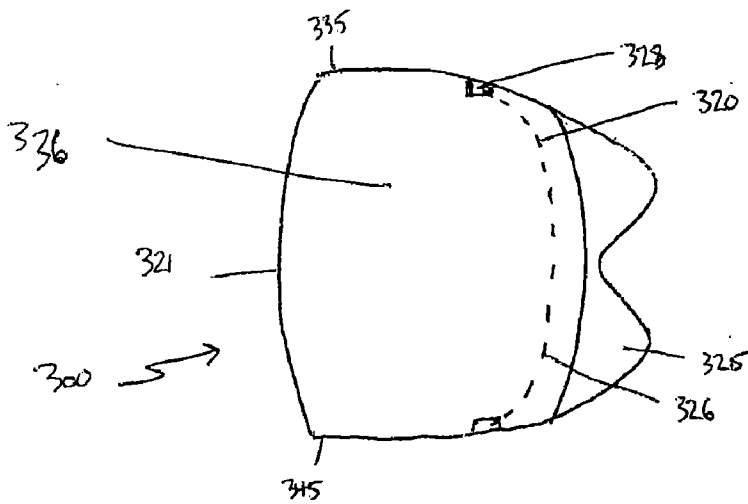

FIG. 20

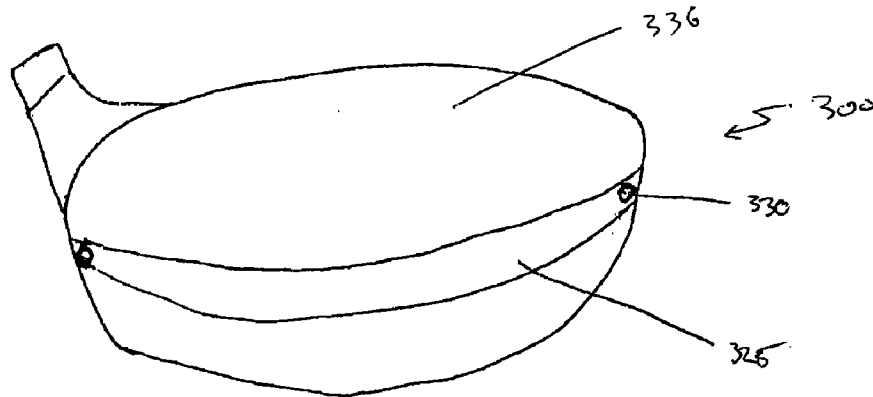

FIG. 21

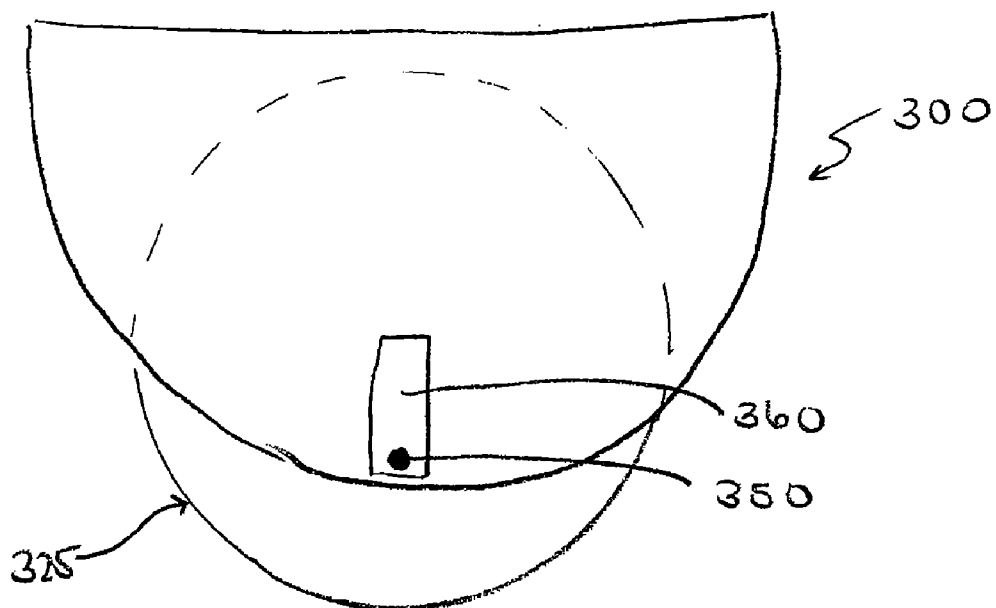

FIG. 22

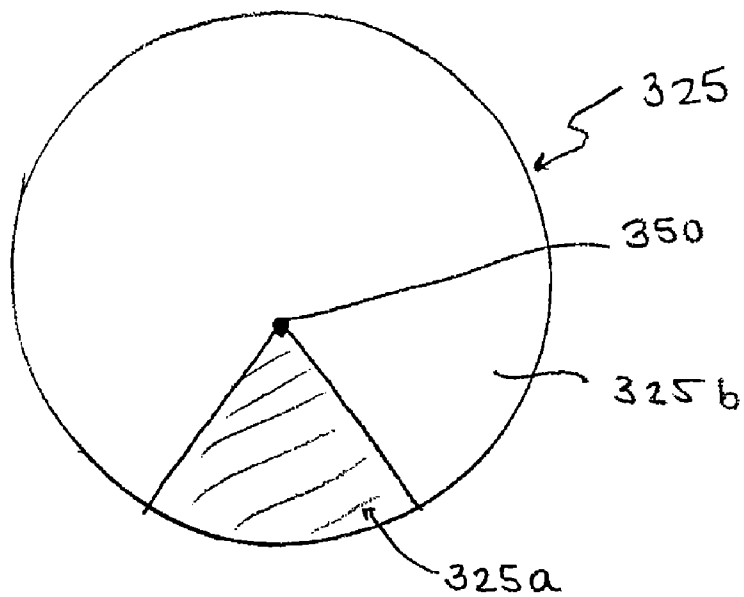

FIG. 23

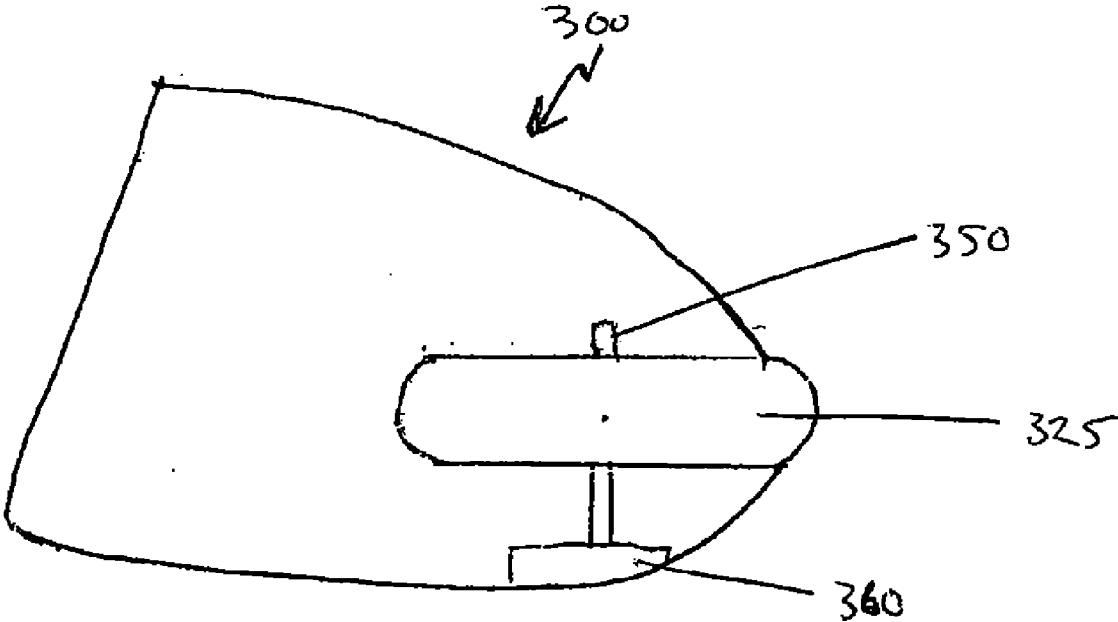

FIG. 24

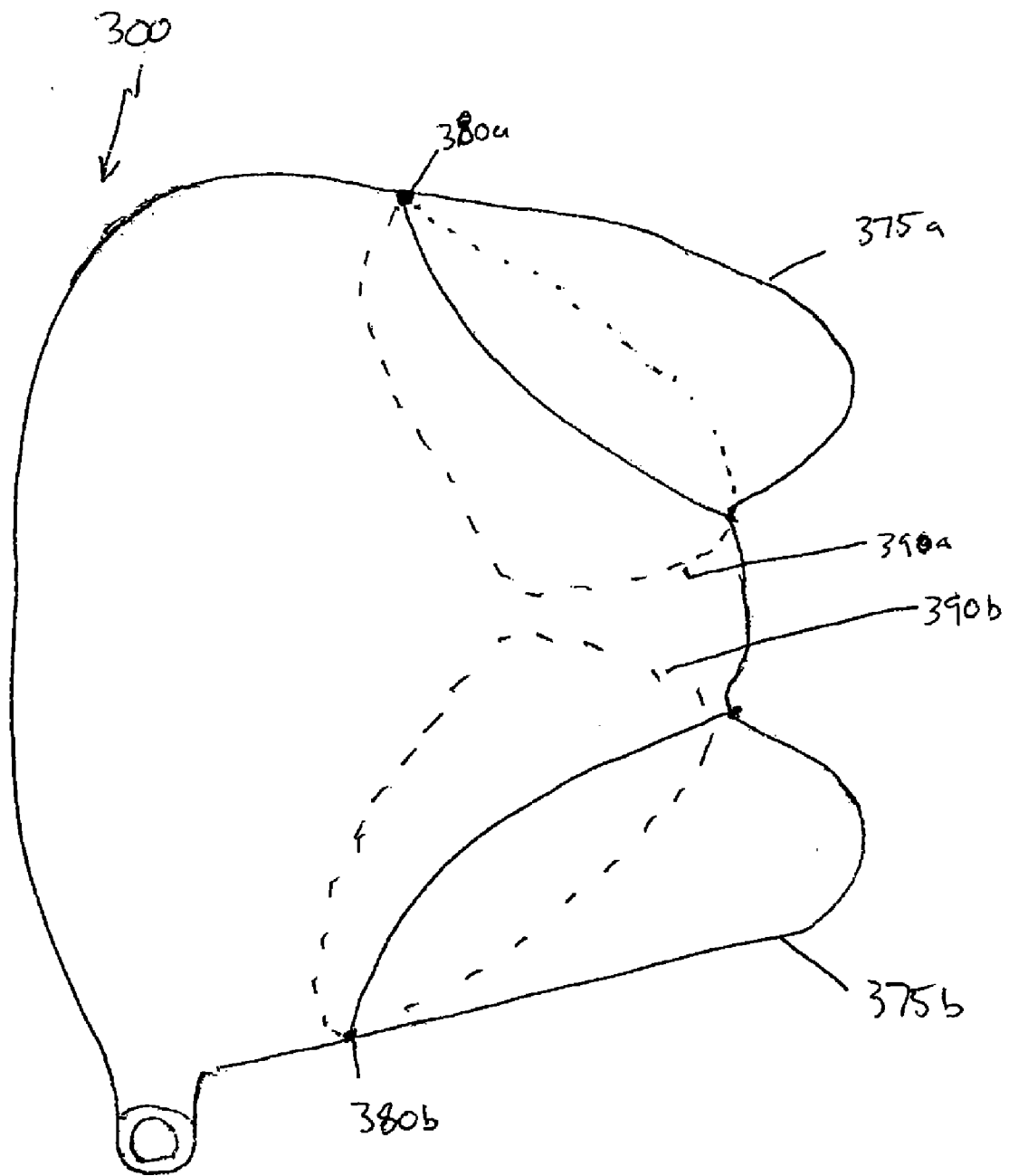

FIG. 25

GOLF CLUB HEAD WITH MOVEABLE INSERT

CROSS REFERENCE TO RELATED APPLICATIONS

[0001] This is a continuation-in-part of U.S. patent application Ser. No. 12/076,322, filed on Mar. 17, 2008, now pending, which is a continuation-in-part of U.S. patent application Ser. No. 11/363,098, filed on Feb. 28, 2006, now pending, which is a continuation-in-part of U.S. patent application Ser. No. 11/110,733, filed on Apr. 21, 2005, now pending, and a continuation-in-part of U.S. patent application Ser. No. 11/180,406, filed on Jul. 13, 2005, now U.S. Pat. No. 7,377,860. Each of these applications is incorporated herein by reference in their entireties.

FIELD OF THE INVENTION

[0002] The present invention generally relates to a golf club head with enhanced weight distribution and mechanical properties. In particular, the present invention relates to a metal wood type club with a moveable insert, which allows for a maximization of legal club head dimensions and the ability to manipulate various characteristics of the club head.

BACKGROUND OF THE INVENTION

[0003] Golf club heads come in many different forms and makes, such as wood- or metal-type (including drivers and fairway woods), iron-type (including wedge-type club heads), utility- or specialty-type, and putter-type. Each of these styles has a prescribed function and make-up. The present invention primarily relates to hollow golf club heads, such as wood-type and utility-type (generally referred to herein as wood-type golf clubs).

[0004] Wood-type type golf club heads generally include a front or striking face, a crown, a sole, and an arcuate skirt including a heel, a toe, and a back. The crown and skirt are sometimes referred to as a "shell." The front face interfaces with and strikes the golf ball. A plurality of grooves, sometimes referred to as "score lines," may be provided on the face to assist in imparting spin to the ball and for decorative purposes. The crown is generally configured to have a particular look to the golfer and to provide structural rigidity for the striking face. The sole of the golf club contacts and interacts with the ground during the swing.

[0005] The design and manufacture of wood-type golf clubs requires careful attention to club head construction. Among the many factors that must be considered are material selection, material treatment, structural integrity, and overall geometrical design. Exemplary geometrical design considerations include loft, lie, face angle, horizontal face bulge, vertical face roll, face size, sole curvature, center of gravity, and overall head weight. In addition, the interior design of the club head may be tailored to achieve particular characteristics, such as by including hosel or shaft attachment means, perimeter weighting on the face or body of the club head, and fillers within hollow club heads.

[0006] Club heads typically are formed from stainless steel, aluminum, or titanium, and may be cast, stamped by forming sheet metal with pressure, forged, or formed by a combination of any two or more of these processes. In fact, clubs were originally manufactured primarily by casting durable metallic material such as stainless steel, aluminum, beryllium copper, etc. into a unitary structure comprising a metal body, face,

and hosel. However, as technology progressed, it became more desirable to increase the performance of the face of the club, usually by using a titanium material. Today, the club heads may be formed from multiple pieces that are welded or otherwise joined together to form a hollow head, as is often the case of club heads designed with inserts, such as sole plates or crown plates.

[0007] The multi-piece constructions facilitate access to the cavity formed within the club head, thereby permitting the attachment of various other components to the head such as internal weights and the club shaft. The cavity may remain empty, or may be partially or completely filled, such as with foam. An adhesive may be injected into the club head to provide the correct swing weight and to collect and retain any debris that may be in the club head. In addition, due to difficulties in manufacturing one-piece club heads to high dimensional tolerances, the use of multi-piece constructions allows the manufacture of a club head to adhere to a tighter set of standards.

[0008] With a high percentage of amateur golfers constantly searching for more distance on their shots, particularly their drives, the golf industry has responded by providing golf clubs specifically designed with distance in mind. The head sizes of wood-type golf clubs have increased, allowing the club to possess a higher moment of inertia, which translates to a greater ability to resist twisting on off-center hits. As a wood-type club head becomes larger, its center of gravity will be moved back away from the face and further toward the toe, resulting in hits flying higher and further to the right than expected (for right-handed golfers). And, because the center of gravity is moved further away from hosel axis, the larger heads can also cause these clubs to remain open on contact, thereby inducing a "slice" effect (in the case of a right-handed golfer the ball deviates to the right).

[0009] While a reduction in loft of a larger club head, offsetting the head, and/or incorporating a hook face angle may help to compensate for this shift in the center of gravity and resulting higher and right-biased hits by "squaring" the face at impact, none of these methods are completely sufficient in solving the issues relating to the larger club heads.

[0010] Another technological breakthrough in recent years to provide the average golfer with more distance is to make larger head clubs while keeping the weight constant or even lighter by casting consistently thinner shell thicknesses and using lighter materials such as titanium, magnesium, and composites. Also, the faces of the clubs have been steadily becoming extremely thin, because a thinner face will maximize what is known as the Coefficient of Restitution (COR). For example, the more a face rebounds upon impact, the more energy is imparted to the ball, thereby increasing the resulting shot distance.

[0011] With the emphasis on thinner shells, strategic weighting has become important to club manufacturers. Accordingly, weight elements are usually placed at specific locations believed to have a positive influence on the flight of the ball or to overcome a particular golfer's shortcomings. As previously stated, a major problem area of the higher handicap golfer is the tendency to "slice," which, in addition to deviating the ball to the right, also imparts a greater spin to the ball, thus further reducing the overall shot distance.

[0012] As such, a need exists in the art to further enhance weight distribution of a golf club head in order to reduce or eliminate the higher spin and "slice effect" currently an issue with the larger club heads. In addition, it would be advanta-

geous to maximize playability of the club by maximizing the dimensions allowable by the USGA, both heel to toe and face to back. The present invention contemplates such enhancements.

SUMMARY OF THE INVENTION

[0013] The present invention is directed toward a golf club head. In particular, the golf club head comprises a body defined by a face, a back, a heel, a toe, a sole, a crown, and at least one adjustable insert. The adjustable insert is capable of movement in the face to back direction. The adjustable insert has at least one adjustment mechanism and at least one locking mechanism, which allows for the insert to be locked into at least one position. In one embodiment, the insert is capable of movement in increments of less than about 0.05 inch. According to one aspect of the invention, the adjustable insert is rotatable about a center axis

[0014] The adjustment mechanism may take many forms. For example, the adjustment mechanism may comprise a plurality of notches located on the body of the club head and a deformable tab located on the adjustable insert and designed to fit within a notch.

[0015] The club head has a first distance from the toe to the heel. In addition, the club head has a second distance from the face to the back without the adjustable insert. Finally, the club head has a third distance from the face to the back of the adjustable insert when the insert is extended to a maximum in the face to back direction. In one embodiment, the third distance is greater than about 5 inches. The third distance may be greater than or equal to the first distance times 1.10. The third distance may be greater than or equal to the first distance times 1.05. In another embodiment, the third distance may be greater than or equal to the first distance times 1.00. The third distance may be greater than or equal to 1.05 times the second distance. In another embodiment, the third distance may be greater than or equal to 1.50 times the second distance.

[0016] In one embodiment, the adjustable insert comprises a portion with a specific gravity greater than the specific gravity of the body. For example, the specific gravity of a portion of the insert may be about 7 or more. The high specific gravity portion may comprise less than about 40 percent of the total volume of the adjustable insert. In one embodiment, the high specific gravity portion may be less than about 20 percent of the total volume of the adjustable insert. The high specific gravity portion may be located substantially on the toe side, the heel side, or on both sides of the insert.

[0017] According to one aspect of the invention, the adjustable insert may have a low specific gravity portion with a specific gravity lower than that of the body. For example, the specific gravity of the low specific gravity portion may be less than about 4. In another embodiment, the adjustable insert further comprises a first portion and a second portion, the second portion has a specific gravity greater than the first portion, and the second portion comprises up to about 30 percent of the total volume of the adjustable insert.

BRIEF DESCRIPTION OF THE DRAWINGS

[0018] The present invention is described with reference to the accompanying drawings, in which like reference characters reference like elements, and wherein:

[0019] FIG. 1 shows a golf club head of the present invention;

[0020] FIG. 2 shows a body member of the golf club head of FIG. 1;

[0021] FIG. 3 shows a second club head of the present invention;

[0022] FIG. 4 shows a bottom view of the club head of FIG. 3;

[0023] FIG. 5 shows a bottom perspective view of a club head of the present invention;

[0024] FIG. 6 shows a rear elevation view of the club head of FIG. 5;

[0025] FIG. 7 shows a heel elevation view of the club head of FIG. 5;

[0026] FIG. 8 shows a bottom schematic view of the club head of FIG. 5;

[0027] FIG. 9 shows a front cross-sectional view of the club head of FIG. 5;

[0028] FIG. 10 shows a bottom view of a golf club head of the present invention;

[0029] FIG. 11 shows a bottom view of a golf club head of the present invention;

[0030] FIG. 12 shows a cross-sectional view of the club head of FIG. 11 taken along line 12-12;

[0031] FIG. 13 shows an exploded top view of a golf club head of the present invention;

[0032] FIG. 14 shows an exploded top view of the golf club head of FIG. 13;

[0033] FIG. 15 shows a first club head component and its projected area;

[0034] FIG. 16 shows a second club head component and its projected area;

[0035] FIG. 17 shows a top view of the club head of FIG. 13;

[0036] FIG. 18 shows a club head of the invention with an adjustable insert;

[0037] FIG. 19 is a toe side view of the golf club head shown in FIG. 18;

[0038] FIG. 20 is a top view of the golf club head of the club head of FIG. 18;

[0039] FIG. 21 is a rear view of the golf club head of the club head of FIG. 18;

[0040] FIG. 22 is a top view of a club head of the invention with a fully extended adjustable insert;

[0041] FIG. 23 shows the adjustable insert of FIG. 22 according to an embodiment of the invention;

[0042] FIG. 24 is a side view of a club head of the invention with an adjustable insert; and

[0043] FIG. 25 shows a top view of a club head of the invention.

DETAILED DESCRIPTION OF THE INVENTION

[0044] The present invention is directed to enhanced weighting of a club head. In one aspect of the invention, weight elements are incorporated directly into the club head. The placement of weight elements is designed so that the spin of the ball will be reduced and also so that a "draw" (a right-to-left ball flight for a right-handed golfer) will be imparted to the ball flight. This ball flight pattern is also designed to help the distance-challenged golfer because a ball with a lower spin rate will generally roll a greater distance after initially contacting the ground than would a ball with a greater spin rate.

[0045] In another aspect of the invention, the club head has an adjustable insert that is capable of movement in the face to back direction and is further capable of locking into a desired

location. The insert may be adjusted so that the total distance from the face to the back of the club when the insert is fully extended approaches about 5 inches. The total distance from the face to the back of the club when the insert is fully extended may be related to the distance from the toe to the heel. For example, the total distance from the face to the back with the insert at a fully extended position may be greater than the distance from the toe to the heel of the golf club, which allows for the golfer to adjust the face to back distance to approach a predetermined distance.

[0046] In yet another aspect of the invention, at least a portion of the club head of the invention is treated with a thermal or combustion spray coating to alter the weight distribution of the club head. The coating may be applied to the interior and/or exterior of the club head.

[0047] Each aspect is discussed in greater detail below.

Weighted Inserts

[0048] FIG. 1 shows a golf club head 1 of the present invention. The club head 1 includes a body 10 having a strike face 11, a sole 12, a crown 13, a skirt 14, and a hosel 15. The body 10 defines a hollow, interior volume 16. Foam or other material may partially or completely fill the interior volume 16. Weights may optionally be included within the interior volume 16. The face 11 may be provided with grooves or score lines therein of varying design. The club head 1 has a toe T and a heel H.

[0049] The club head 1 is comprised of a plurality of body members that cooperatively define the interior volume 16. A first body member 101 includes a sole portion and a face portion. The first body member 101 may include a complete face 11 and sole 12. Alternatively, either or both the face 11 and the sole 12 can be inserts coupled to the first body member 101. The club head 1 also includes at least one second body member 102 coupled to the first body member 101 along the skirt 14 in known fashion. The crown 13 can be unitarily a portion of either body member 101, 102 or it may be an insert coupled to either of the body members 101, 102. The second body member 102 includes a concave portion 20 that, when the body members 101, 102 are coupled together, extends inward into the interior volume 16. FIG. 2 shows an isolated view of an exemplary second body member 102.

[0050] The first body member 101 preferably is formed of a metallic material such as stainless steel, aluminum, or titanium. The material of the first body member 101 is chosen such that it can withstand the stresses and strains incurred during a golf swing, including those generated through striking a golf ball or the ground. The club head 1 can be engineered to create a primary load bearing structure that can repeatedly withstand such forces. Other portions of the club head 1, such as the skirt 14, experience a reduced level of stress and strain and advantageously can be replaced with a lighter, weight-efficient secondary material. Lighter weight materials, such as low density metal alloys, plastic, composite, and the like, which have a lower density or equivalent density than the previously mentioned metallic materials, can be used in these areas, beneficially allowing the club head designer to redistribute the "saved" weight or mass to other, more beneficial locations of the club head 1. These portions of the club head 1 can also be made thinner, enhancing the weight savings.

[0051] Exemplary uses for this redistributed weight include increasing the overall size of the club head 1, expanding the size of the club head "sweet spot," which is a term that refers

to the area of the face 11 that results in a desirable golf shot upon striking a golf ball, repositioning the club head 1 center of gravity, and/or producing a greater moment of inertia (MOI). Inertia is a property of matter by which a body remains at rest or in uniform motion unless acted upon by some external force. MOI is a measure of the resistance of a body to angular acceleration about a given axis, and is equal to the sum of the products of each element of mass in the body and the square of the element's distance from the axis. Thus, as the distance from the axis increases, the MOI increases, making the club more forgiving for off-center hits since less energy is lost during impact from club head twisting. Moving or rearranging mass to the club head perimeter enlarges the sweet spot and produces a more forgiving club. Increasing the club head size and moving as much mass as possible to the extreme outermost areas of the club head 1, such as the heel H, the toe T, or the sole 12, maximizes the opportunity to enlarge the sweet spot or produce a greater MOI, making the golf club hotter and more forgiving.

[0052] The second body member 102 is light-weight, which gives the opportunity to displace the club head center of gravity downward and to free weight for more beneficial placement elsewhere without increasing the overall weight of the club head 1. When the wall thickness of the second body member 102 is at the minimum range of the preferred thickness, a reinforcing body layer can be added in the critical areas in case the member shows deformations. These benefits can be further enhanced by making the second body member 102 thin. To ensure that the structural integrity of the club head 1 is maintained, these thin panels may preferably include a concave portion 20. Inclusion of these concave portions 20 allow the second body member 102 to withstand greater stress, both longitudinally and transversely, without sustaining permanent deformation or affecting the original cosmetic condition, ensuring the structural integrity of the club head 1 is maintained.

[0053] In one embodiment, the thickness for the first body member 101 may range from about 0.03 inch to about 0.05 inch, preferably from about 0.035 to about 0.045 inch. The thickness for the second body member 102 may range from about 0.015 inch to about 0.025 inch, preferably from about 0.018 inch to about 0.022 inch.

[0054] The concave portion 20 may displace at least about 10 cubic centimeters. More preferably, the concave portion 20 displaces at least about 20 cubic centimeters, and even more preferably, about 25 cubic centimeters. While the club head 1 can be virtually any size, preferably it is a legal club head. A plurality of concave portions 20 may be used with the club head 1. For example, concave portions 20 of uniform or varying size may be positioned in the toe, heel, back, etc.

[0055] FIG. 3 shows a cross-sectional view taken substantially perpendicular to the face 11 of a second club head 2 of the present invention, and FIG. 4 shows a bottom view of the club head 2. In the illustration of this embodiment, the concave portion 20 is positioned at the back of the club head 2. The concave portion 20 preferably is not visible to the golfer at address. In addition to the concave portion 20, the second body member 102 further includes a convex bulge 22 that extends generally away from the interior volume 16.

[0056] At least one insert 23 may be positioned within the convex bulge 22. The insert 23 is not visible from outside the club head 2, and is thus illustrated using broken lines. In a preferred embodiment, the insert 23 is a weight insert. The

convex nature of the bulge **23** allows the weight to be positioned to maximize the mechanical advantage it lends to the club head **2**.

[0057] As shown in FIG. 4, the club head **2** may include a plurality of convex bulges **22**, such as on a heel side and on a toe side of the club head **2**. The club designer may place inserts **23** as desired within the bulges **22**. The masses of the inserts may be substantially equal. Alternatively, one of the inserts may have a greater mass than the other. This may be beneficial to design the club to correct a hook swing or a slice swing. A preferred mass range for the weight insert **23** is from 1 gram to 50 grams.

[0058] As shown in FIG. 3, the first body member **101** may comprise a majority of the sole **12** and the second body member **102** may include a majority of the crown **13**. This beneficially removes a large majority of the mass from the upper part of the club head **2**. In this embodiment, the first body member **101** includes an attachment perimeter **18** that extends around its edge. The second body member **102** is coupled to the first body member **101** along the attachment perimeter **18**. Thus, the first and second body members **101**, **102** cooperatively define the interior volume **16**.

[0059] The attachment perimeter **18** preferably may contain a step defining two attachment surfaces **18a**, **18b**. As illustrated, the second body member **102** may be coupled to both of these surfaces **18a**, **18b** to help ensure a strong bond between the body members **101**, **102**.

[0060] While the body members **101**, **102** may be formed in a variety of manners, a preferred manner includes forming a complete club head shell (first body member **101**) in known manner and removing material to create openings to which the second body member **102** can be coupled. The opening may be created in any desired manner, such as with a laser. The second body member **102** may be joined to the first body member **101** in a variety of manners, such as through bonding or through a snap-fit in conjunction with bonding. If a composite material is used for the concave inserts, molding six plies of 0/90/45/-45/90/0 is preferred.

[0061] FIGS. 5-9 illustrate additional aspects of the present invention. In the embodiment illustrated in these figures, the club head **1** includes a crown portion **13**, a sole **12**, a heel portion **H**, a toe portion **T**, a skirt portion **14** connecting the heel portion **H** to the toe portion **T**, a front face **11** and a hosel **24** that extends from the heel portion **H**. The club head **1** can be formed from sheets joined together, such as by welding, or cast, preferably from a titanium alloy. The crown portion **13** can be made from such materials as carbon fiber composite, polypropylene, Kevlar, magnesium, continuous fiber reinforced thermoplastic, BMC, or a thermoplastic. Hosel **24** includes a bore defining a centerline axis *C/L*.

[0062] As best depicted in FIG. 9, the club head **1** of the present invention has a center of gravity **G** located at an extremely rearward and low position. The location of the center of gravity **G** is biased by the location of two secondary weights, a toe secondary weight **26** and a heel secondary weight **28**, which are both partially outside the traditional look of a golf club head. As shown in FIGS. 5-9, the locations of the two secondary weight elements **26**, **28** are established by the relationship of their distances from established points of contact. When the club head is at a lie angle θ of 59°, the lowest contact point of the sole **12** is at a center point **C** directly beneath the center of gravity **G**.

[0063] One method of establishing the locations of the secondary weights **26**, **28** is discussed herein. As shown in FIG.

8, the center line *C/L* of hosel **24** intersects the sole plate **12** at a distance **D** from the rear surface of the front face **11**. When extending a line *B-B* that is substantially parallel to the leading edge of the club head (maintaining the distance **D**), an intersection point **P** is made with a line *A-A* that is perpendicular to and extends rearward from the midpoint of the front face **11**. The line *A-A* extends through the middle of the club head **1** and passes directly beneath the club head center of gravity **G**. This intersection point **P** may also be defined by the intersection of line *A-A* and a vertical plane positioned at an intersection of the hosel center line *C/L* and the sole **12**.

[0064] The center of gravity *C/G* of each secondary weight **26**, **28** is at a distance **W** of at least 1.50 inches rearward of the intersection point **P**, a distance **Z** that is a maximum of 0.25 inch above the lowest point of contact, which is the center point **C** of the sole plate **12** and each secondary weight is at least about 0.75 inch away from line *A-A* in opposing directions, which is a distance **Y1** towards the toe **T** for the toe secondary weight **26** and a distance **Y2** towards the heel **H** for the heel secondary weight **28**.

[0065] The locations of the secondary weights **26**, **28** may also be determined for the present invention by measuring from the center point **C**. From center point **C**, the center of gravity of each secondary weight **26**, **28** is a distance **X** of at least about 0.50 inch rearward along line *A-A*, the distance **Z** that is a maximum of about 0.25 inch above the center point **C**, and a minimum of about 0.75 inch away from line *A-A* in opposing directions, towards the toe **T** for the toe secondary weight **26** and towards the heel **H** for the heel secondary weight **28**. Thus, each secondary weight **26**, **28** is a minimum of about 0.90 inch from the center point **C**.

[0066] The secondary weights **26**, **28** can be selected from a plurality of weights designed to make specific adjustments to the club head weight. The secondary weights **26**, **28** can be welded into place or attached by a bonding agent. The weights **26**, **28** can be formed from typically heavy weight inserts such as steel, nickel, or tungsten. Preferably, the body of the club head **1** is formed from titanium, and the crown portion **13** from a light-weight material such as carbon fiber composite, polypropylene, Kevlar, thermoplastic, BMC, magnesium, or some other suitable light-weight material.

[0067] Preferred volumes of the club head **1** include from 350 cc to 460 cc. The secondary weights **26**, **28** preferably range in mass from 2 to 35 grams, with 10 grams to 35 grams being more preferred. It is well known that by varying parameters such as shaft flex points, weights and stiffness, face angles, and club lofts, it is possible to accommodate a wide spectrum of golfers. But the present invention addresses the most important launch consideration, which is to optimize the club head mass properties (center of gravity and moment of inertia) by creating a center of gravity that is low, rearward, and wide of center. The club head **1** of the present invention encompasses areas of the club head that are not typically utilized for weighting because they adversely alter the traditional look of a club head. The design of this club head **1** allows for a portion of the secondary weights **26**, **28** to bulge outside the normal contour of the club head.

[0068] FIG. 10 shows a bottom view of a golf club head **1** of the present invention. The skirt **14** includes an opening **30** towards the rear of the club head **1**. An insert **35** is positioned within the opening **30** in known fashion, such as via an attachment perimeter **18**, to cooperatively define the interior volume **16**. Preferably, the insert **35** is formed of a light-weight material such as a composite material or a polymer material.

Using a light-weight insert **35** inherently biases the club head mass toward the sole **12** of the club head **1**. It also allows the inclusion of a weight member to achieve a specific moment of inertia and/or center of gravity location while maintaining typical values for the overall club head weight and mass.

[0069] FIG. **11** shows a bottom view of a golf club head **1** of the present invention. In addition to secondary weights **26**, **28**, the club head **1** includes an insert **27** intermediate the toe secondary weight **26** and the heel secondary weight **28**. The insert **27** may be a weight insert similar to the toe and heel secondary weights **26**, **28**, in which case it also has a preferable mass range of 2 to 35 grams. Alternatively, or in addition to being a weight member, insert **27** may include one or more indicia, such as a model or manufacturer designation.

[0070] The club head **1** further includes a sole insert **105**; in the illustrated embodiment, two such sole inserts **105** are shown. These inserts **105** preferably are formed of a light-weight material as described above. Such materials likely are robust enough to withstand contact with the ground such as the sole **12** incurs through normal use of the golf club. However, the arcuate shape of the sole **12** in the illustrated embodiment minimizes the likelihood of the inserts **105** contacting the ground. Inclusion of the sole inserts **105** frees even more mass for more beneficial placement in the club head, such as at toe insert **26**, intermediate insert **27**, and/or heel insert **28**. The location of the inserts **105** toward the center of the sole **12** inherently biases the mass toward the outer portions of the club head **1**, improving the club head MOI.

[0071] FIG. **12** shows a cross-sectional view of the club head **1** of FIG. **11** taken along line **12-12**. Here it is seen that the crown **13** is an insert that is coupled to the metallic first body member **101**. The crown insert **13** preferably is formed of a light-weight material, beneficially displacing the club head center of gravity downward and freeing yet more weight for more beneficial placement elsewhere without increasing the overall weight of the club head **1**. Due to the inclusion of holes in which to position the crown insert **13**, the skirt insert **35**, the second body member inserts **102**, and the sole inserts **105**, the first body member **101** takes on the appearance of a frame.

[0072] It should be noted that not every insert **13**, **35**, **102**, **105** need be included in a particular embodiment of the present invention, though all may be present. The frame-like nature of first body member **101** is a load bearing structure that ensures that the stresses and strains incurred during a golf swing, including those generated through striking a golf ball or the ground, do not detrimentally affect the light-weight portions of the club head **1**, which experience a reduced level of stress and strain. These club head portions, which may include secondary body member **102**, crown **13**, skirt insert **35**, and sole inserts **105**, advantageously can be formed of a lighter, weight-efficient secondary material such as low density metal alloys, plastics, composites, and the like, which have a lower density or equivalent density than the previously mentioned metallic materials, beneficially allowing the club head designer to redistribute the “saved” weight or mass to other, more beneficial locations of the club head **1**. These portions of the club head **1** can also be made thinner, enhancing the weight savings.

[0073] The first body member **101** preferably includes an attachment perimeter **18** for each insert (including the crown **13**). These attachment perimeters **18** extend around the edge of the respective openings. Preferably, each attachment perimeter **18** includes a step defining two attachment surfaces

18a, **18b**, which provide additional assurance of a strong bond between the respective club head components. (While each attachment perimeter **18** of FIG. **12** includes a step defining two attachment surfaces **18a**, **18b**, such attachment surfaces **18a**, **18b** are called-out in only one location for the sake of clarity.)

[0074] The openings in the club head **1** into which the inserts **13**, **35**, **102**, **105** are positioned preferably may be created by forming a complete club head shell in known fashion, and then creating the openings therein. One preferred method of creating the openings is by using a laser to remove portions of the metallic material of the first body member **101**. This method provides for tight tolerances. The attachment perimeter **18**, including attachment surfaces **18a**, **18b**, may be formed in a variety of manners, such as machining the first body member **101** after laser cutting the opening in the club head **1**.

[0075] Each sole insert **105** preferably has a mass of 0.5 gram to 10 grams, and more preferably from 1 gram to 5 grams. The sole inserts **305**, as well as the other inserts, may be beveled or stepped slightly to provide a location for any excess adhesive. In one embodiment, the toe and heel sole inserts **26**, **28** each have a preferred mass range of 4 grams to 7 grams, while the intermediate insert sole **27** has a preferred mass range of 2 grams to 3 grams. In one embodiment, the thickness of the club head components is tapered such that the walls are thicker towards the face **11** and thinner towards the rear of the club head **1**. Such wall thickness tapering frees more mass for more beneficial placement in the club head **1**.

[0076] As discussed above, certain golf club head geometries have an inherent advantage over typical design shapes with respect to the club head’s mass properties, especially in view of the dimension limits mandated by the United States Golf Association (USGA) and the Royal and Ancient Golf Club of St. Andrews (R&A), the governing bodies promulgating the Rules of Golf. Two such properties of particular note are the club head center of gravity (CG) height and the club head MOI in the heel/toe twisting direction about a vertical axis passing through the CG. (The limit for this MOI is 5900 g·cm².)

[0077] Further to the discussion above, material selection and distribution plays an important role in determining the club head properties, including these two specific properties.

[0078] Modern drivers have gone from predominately made of steel in the 1990s to titanium alloys in the 2000s as the driver size, measured by volume, have gone from around 250 cc to the maximum allowed 460 cc. While maintaining a certain volume as a constant, the surface area of the club head may be varied. A sphere would be the smallest body for a given volume, while a rectangle with twice the footprint can have the same volume as the sphere. For example, a sphere has a minimum amount of surface area surrounding a given volume while the rectangle has a much greater amount of surface area. With that logic, and the fact that there are inherent limits to how thin walls can be made using certain metals—and furthermore if the walls do reach the desired minimal thickness, secondary durability issues, such as denting, arise—certain materials reach their practical limit. While stiffening ribs can be added to help overcome denting, this becomes a complex and costly solution and may offer only marginal improvement.

[0079] Considering for example titanium, which has a density of approximately 4.43 gm/cc, current manufacturing techniques can obtain wall thickness in the range of 0.5-0.7

mm at a reasonable cost. For a “traditional” shaped profile for a 460 cc driver approaching the Rule limits in width and depth of 12.7 cm, the surface area (SA) required is approximately 380 cm². Using a wall thickness of 0.06 cm, the minimum amount material of titanium required is 101 g titanium (calculated as area·thickness·density). However, certain areas of the club need to be substantially thicker than the minimum wall thickness for a variety of reasons. One such area is the face **11**. Variable face thicknesses are typical in modern drivers, with thicknesses ranging from about 0.2 cm near the outer periphery and up to 0.4 cm or more in the central region. Most face areas do not approach the Rule limit of 12.7 cm (5 in)×7.1 cm (2.8 in), which represents a SA of 90 cm². Certain drivers manufactured by Cobra Golf have a large face area, measuring around 54 cm². Assuming for calculation purposes that a uniform thickness of 0.28 cm is used for the face to achieve its functional requirements, then 67 g of titanium is needed for the face. Thus the total amount of titanium used is:

$$\begin{aligned}
 \text{Total amount} &= \text{face mass} + \text{body mass} \\
 &= (\text{face SA} \cdot \text{face thickness} \cdot \text{density}) + \\
 &\quad \left(\frac{\text{body SA} - \text{face SA}}{\text{body thickness} \cdot \text{density}} \right) \\
 &= (54 \text{ cm}^2 \cdot 0.28 \text{ cm} \cdot 4.43 \text{ g/cc}) + \\
 &\quad \left(\frac{(380 \text{ cm}^2 - 54 \text{ cm}^2)}{0.06 \text{ cm} \cdot 4.43 \text{ g/cc}} \right) \\
 &= 67 \text{ g} + 86.6 \text{ g} \\
 &= 153.6 \text{ g}
 \end{aligned}$$

[0080] For current driver club building specifications having a shaft length of 45.5 in, the overall club head mass is about 200 g. The amount of free mass is thus 46.4 g to optimize certain playing characteristics. Furthermore, the maximum shaft length allowed by the Rules is 48 in, and when shafts are lengthened the heads traditionally become lighter. A rule of thumb is that for every 0.5 in shaft length increase, the head mass must decrease by 5 g. Thus, with a 48 in. shaft, the maximum mass for the club head is 175 g, leaving little discretionary mass for the club head designer to manipulate.

[0081] Increasing the face area to the maximum allowable value enhances the playability of the resulting golf club, but presents additional challenges to the club head designer. Namely, the inventive golf club head is contoured to control the club head attributes and volume, which increases the club head body SA. At the same time, the face thickness would most likely need to be increased to maintain its functional requirements. For quick calculations, the following assumptions are made: face SA=76 cm², face thickness=0.34 cm, body SA=400 cm², and body thickness=0.06 cm. This results in a club head mass of 200 g, virtually eliminating discretionary mass available to the club head designer for strategically weighting the club head.

[0082] This suggests that there is a limit to how much surface area of the club head can be provided in titanium. One aspect of the instant invention is the use of lightweight metallic materials with densities less than 4.0 g/cc as the primary or only (including alloys) material for both the face and body in heads with large volumes (i.e., greater than 400 cc), large

overall surface areas (i.e., greater than 350 cm²), large face areas (i.e., greater than 60 cm²), and plan profiles approaching the Rule limits (12.7 cm heel-toe distance, less than 12.7 cm face-back distance). As used herein, plan profile means the smallest rectangle that can be drawn around the widest toe-heel and front-back dimensions of the club head projected onto a plane. The plan profile defines a side wall ratio, which is defined as the widest toe-heel dimension divided by the widest front-back dimension. Preferably, the club head has a plan profile area of at least 130 cm², and more preferably at least 145 cm². The inventive club, having these dimensions and materials, has increased forgiveness and increased playability for golfers of various skill levels.

[0083] Preferred materials for the inventive club head include aluminum, its alloys, metal matrix aluminum composites, aluminum cermets (ceramic-reinforced metals), and the like. Such materials may have material strengths that are comparable to the widely used titanium alloys. Use of such materials have a density less than 3 g/cc, yielding a lower total club head mass even with increased wall thicknesses. For example, using such an aluminum-based material having a density of 2.8 to form the body and face of a golf club head having an overall surface area of 400 cm², the face having a surface area of 76 cm² and a thickness of 0.4 cm, and the body having a thickness of 0.1 cm, the total club head mass is about 175.8 g. This represents a “savings” of more than 24 g relative a titanium-based club head. The club head designer may use this saved mass to strategically position weight members to the club head, increasing the club head MOI, lowering the club head CG, and enhancing the forgiveness and playability of the resulting golf club.

[0084] In an alternate version of the inventive club head, a combination of a relatively heavier material and a lightweight material is used to form the club head body. FIG. 13 shows an exploded top view of a golf club head **200** of the present invention. The club head **200** includes a body formed of two major components. A first component **210** is formed of a relatively heavier material, preferably a metallic material, and includes the strike face **11**, which may be an insert or formed integrally therewith. The metallic component **210** further includes wing-like projections **211**, **212** extending rearward from toe and heel portions of the face **11**, respectively, partially forming the skirt **14** of the club head **200**. The wing extensions **211**, **212** define voids therebetween, including in crown and sole portions of the club head. Thus, the metallic component **210** has a frame-like design.

[0085] A second major component **220** is formed of a lightweight material and cooperates with the metallic component **210** to define the club head **200**. Preferred materials for the second component **220** include reinforced plastic and other composites. The first and second components **210**, **220** are coupled together in known manner, such as through an adhesive, epoxy, or the like. The components **210**, **220** can also be coupled via bladder molding or welding. To facilitate their attachment, the components **210**, **220** have corresponding attachment surfaces. Preferably, at least the top, outer surfaces of the projections **211**, **212** and corresponding surfaces of the lightweight component **220** are such attachment surfaces. Preferably, at least portions of the bottom, outer surfaces of the projections **211**, **212** and corresponding surfaces of the lightweight component **220** are also attachment surfaces.

[0086] The lightweight component **220** fills in the voids of the metallic component **210**. Thus, the lightweight compo-

nent forms a majority of the crown **13**, a rear portion of the skirt **14**, and a central portion of the sole **12**. This is illustrated in FIG. **14**, which shows an exploded side view of the club head **200**. By displacing the denser metallic material from the crown, the center of gravity is inherently lowered. Similarly, by displacing the metallic material from the central portion of the sole **13**, mass is inherently biased toward the heel and toe of the club head.

[0087] Similarly to the second body member **102** discussed above, the club head **200** may further include additional lightweight bodies **230** positioned in front heel and toe portions of the skirt **14**, near the strike face **11**. Inclusion of such additional lightweight components displaces further metallic material, further allowing the club designer to enhance the playing characteristics of the golf club.

[0088] One way to characterize the relative amounts of each material is by a ratio of the surface area comprised by the relatively heavier material and that comprised by the lightweight material. It should be noted that, preferably, the “relatively heavier material” is less dense than the metallic materials typically used to form golf club heads. The aluminum materials discussed above are preferred for the “heavy” material, and carbon fiber or otherwise reinforced plastic composites are preferred for the lightweight material. The surface area ratio may be compared with a ratio of the densities of the two club head components **210**, **220**. According to one preferred arrangement,

$$\frac{A_2}{A_1} < \frac{\rho_1}{\rho_2} < 5 \cdot \frac{A_2}{A_1},$$

where A_1 is the surface area of the first component **210**, A_2 is the surface area of the second component **220**, ρ_1 is the density of the first component **210**, and ρ_2 is the density of the second component **220**. It is the outer surface areas that are being referred to here. More preferably,

$$\frac{A_2}{A_1} < \frac{\rho_1}{\rho_2} < 3 \cdot \frac{A_2}{A_1}.$$

[0089] Thus, the inventive club head **200** balances the amount of the relatively heavier material (measured as a function of its surface area) with the relative densities of the components **210**, **200**. Preferably, the first density ρ_1 is less than or equal to 3.5, and the first density ρ_1 divided by the second density ρ_2 is less than 2. The greater the difference in relative densities, the greater is the difference in surface areas. This is an inverse relationship, which an increase in the difference in densities causing a decrease in the surface area comprised by the heavier material.

[0090] In addition to the amounts of material present in the club head, the present invention additionally controls the placement of the different materials. This material placement aspect may be quantified as a ratio of projected surface area to actual surface area. That is, for a given portion of the club head, the outer surface area of each component **210**, **200** forming the club head is projected onto a horizontal plane. FIGS. **15** and **16** illustrate this concept. FIG. **15** shows the heavier first club head component **210**. The projected surface area **210a** shown above the first club head component **210** is a projection onto a horizontal plane of that portion of the component **210** above the crown parting line of the club head

components **210**, **220**. The projected area **210b** shown below the first club head component **210** is a projection onto a horizontal plane of that portion of the component **210** below the parting line. The projected area for the first club head component **210** is the sum of these partial projections **210a**, **210b**. The parting line is a convenient location to use to separate the relative club head “halves,” though it is not the only such location available. Similarly, FIG. **16** shows the lighter second club head component **220** with a first projected area **220a** of that portion of the component **220** above the parting line and a second projected area **220b** of that portion of the component **220** below the parting line. The projected area for the second club head component **220** is the sum of these partial projections **220a**, **220b**.

[0091] Due to the contoured nature of the club head, the club head body surface area is increased and the projected area is less than the actual surface area. Preferably, the ratio of projected area divided by actual area is 0.8 or less, and more preferably this ratio is 0.7 or less.

[0092] The concept of equivalent density is useful in describing the inventive club head **200**. The equivalent density is calculated as the density of the material forming each component as a percentage of the surface area for the component relative the total surface area:

$$\rho_{eq} = \frac{\rho_1 \cdot A_1 + \rho_2 \cdot A_2}{A_1 + A_2},$$

where ρ_{eq} is the equivalent density and the other terms are as defined above.

[0093] Of course, equivalent density can be calculated for the entire club head and for specific portions of the club head. FIG. **17** shows a top view of the club head **200** and its plan profile **250**. Two additional plan profiles **251**, **252** are also shown, with all of the plan profiles **250**, **251**, **252** having geometric centers that are coincident. Plan profile **251** has an area equal to 90% of the first plan profile **250** area, and plan profile **252** has an area equal to 80% of the first plan profile **250** area. Each of these secondary plan profiles **251**, **252** has the same side wall ratio as the primary plan profile **250**. Preferably, the inventive golf club head has an equivalent density of less than 2 within the 80% plan profile **252**. Preferably, the inventive golf club head also has an equivalent density of greater than 2 between the 90% plan profile **251** and the primary plan profile **250**. In another aspect of the present invention, this equivalent density between the 90% plan profile **251** and the primary plan profile **250** is greater than 3, or greater than 4.

[0094] Table 1 below shows the attributes of one example of the inventive golf club head **200** and a known golf club head:

TABLE 1

	Example	Comparative
	<u>Main Body</u>	
ρ	2.7	4.43
SA	170	270
	<u>Lightweight insert</u>	
ρ	1.5	1.5
SA	290	110

TABLE 1-continued

	Example	Comparative
	Club Head	
SA	460	380
SA_L/SA_H	1.7	0.41
ρ_H/ρ_L	1.8	2.95

where density ρ is in g/cm^3 , surface area SA is in cm^2 , H designates the heavier material, and L designates the lighter material. As shown, the properties of the inventive club head are an improvement over known club heads.

[0095] The strike face **11** may be integral with or an insert attached to the first component **210**. If an insert, the strike face may be formed of the same material as the first component **210**. Alternatively, the face insert may be formed of a different material, such as titanium or a titanium alloy. Thus, the density of the face may be greater than the density of any of the body components.

[0096] More than one light-weight material can be used with the inventive golf club head. These components may also be comprised of layers of various light-weight materials. If so, the densities, surface areas, and other attributes mentioned herein are of the actual inserts used rather than just one of the various materials used.

[0097] Additionally, the light-weight components of the club head may be treated with a metallic coating to improve their wear resistance. Other coatings may also be used. Preferably, the coating is chosen such that it has only a minor impact, if any, on the club head attributes.

[0098] As used herein, directional references such as rear, front, lower, etc. are made with respect to the club head when grounded at the address position. See, for example, FIG. 9. The direction references are included to facilitate comprehension of the inventive concepts disclosed herein, and should not be read or interpreted as limiting.

Adjustable Inserts

[0099] Another way to alter the golf club head to maximize the playability of the club is to maximize the dimensions. For example, a club designer may desire to have the distance from the face to the back (FB) set as close as possible to the distance from the heel to the toe (HT). Without being bound to any particular theory, it may not be desirable for FB to exceed HT.

[0100] While the current trend in golf club manufacturing is to maximize the dimensions of the golf club to take advantage of the various physical properties allowed by a larger club head, due to manufacturing tolerances, it is not practical in terms of time, labor, or expense to set the face to back (FB) distance near the heel to toe (HT) distance. Thus, traditional methods of manufacturing have set the target manufacturing level of the face to back distance (FB) considerably less than the heel to toe distance (HT), to remove the tolerance consideration.

[0101] However, the adjustable insert contemplated by the inventors allows distance in the face-to-back direction to be maximized by setting the target manufacturing level sufficiently below the HT distance to remove the tolerance considerations while providing a means for adjusting the overall length from face-to-back to approach HT distance. In addition, positioning the insert at the rear of the club and constructing at least a portion of the insert out of a high specific

gravity material serves to move the center of gravity of the club head away from the face.

[0102] The relationship between the distance from the face to the back of the club head with the insert at its maximum extension (MFB) to the distance from the heel to the toe (HT) may be described by the following equations:

$$MFB \geq HT * 1.10 \quad 1)$$

$$MFB \geq HT * 1.05 \quad 2)$$

$$MFB \geq HT * 1.00 \quad 3)$$

[0103] By allowing for the MFB to be greater than the HT, the player is ensured that the club head will have the ability to reach the HT distance. The player may then adjust the insert to ensure that the HT is greater than the MFB, if so desired.

[0104] In the alternative, adjustability of the insert may be expressed as a relationship between the distance from the face to the back of the club head with no insert (XFB) to the distance from the face to the back of the club head with the insert at its maximum extension (MFB). For example:

$$MFB \geq XFB * 1.50 \quad 4)$$

$$MFB \geq XFB * 1.25 \quad 5)$$

$$MFB \geq XFB * 1.10 \quad 6)$$

$$MFB \geq XFB * 1.05 \quad 7)$$

[0105] FIGS. 18-21 illustrate various adjustable inserts according to the invention. For example, golf club head **300** is comprised of a face **321**, a back **320**, a heel **345**, a crown **336**, an adjustable insert **325**, an adjustment mechanism **328**, a locking mechanism **330**, and a sole **338**. In particular, FIGS. 18-19 demonstrate a weight insert **325** coupled to golf club head **300**. Insert **325** is attached to golf club head **300** by way of adjustment mechanism **328** and locking mechanism **330**. In the unlocked position, the insert **325** is capable of movement in the several directions. For example, the insert **325** may be adjusted in a direction from face to back. In the alternative (or in addition to this adjustment), the insert **325** may be adjusted vertically from crown to sole. In the locked position, the insert is incapable of movement.

[0106] Insert **325** may be composed of a single material or a combination of multiple materials. In one embodiment, at least a portion of the insert is composed of a material with a higher specific gravity than the material of the body. For example, the specific gravity of all or a portion of the insert may be about 5 or more, preferably about 7 or more, and more preferably about 9 or more. In comparison to the specific gravity of the body components, the specific gravity of at least a portion of the insert may be greater than the specific gravity of the body by about 4 or more, preferably by about 5 or more, and even more preferably by about 7 or more.

[0107] In one embodiment, the portion of the insert with a higher specific gravity may be less than about 50 percent of the total volume of the insert. In another embodiment, the high specific gravity portion is less than about 40 percent of the total volume of the insert. In still another embodiment, the high specific gravity portion accounts for less than about 20 percent of the total volume of the insert. In the alternative, the insert in its entirety may have a specific gravity that exceeds that of the specific gravity of the body.

[0108] In one embodiment, the portion of the insert with a higher specific gravity than the body is aligned with the horizontal center of the club face when the club is at an

address position. In another embodiment, the high specific gravity portion may be biased toward either the toe or the heel of the club head. Biasing the high specific gravity portion toward either the heel or the toe allows for a golfer with a hook or slice swing to obtain a center of gravity of the club head that will accommodate the golfer's swing.

[0109] Suitable materials for the high specific gravity portion of the insert include, but are not limited to, tungsten and alloys thereof, tungsten loaded polymer, nickel, copper, steel, gold, platinum, depleted uranium, and combinations thereof.

[0110] Alternatively, the insert 325 or at least a portion of the insert 325 may be composed of a low specific gravity material. In this aspect of the invention, the specific gravity of at least a portion of the insert is equal to or less than the specific gravity of the body. For example, the specific gravity of all or a portion of the insert may be less than about 4, preferably less than about 3, and more preferably less than about 1.5.

[0111] In one embodiment, the portion of the insert with a low specific gravity may be less than about 40 percent of the total volume of the insert. In another embodiment, the low specific gravity portion is less than about 30 percent of the total volume of the insert. In yet another embodiment, the low specific gravity portion makes less than about 20 percent of the total volume of the insert.

[0112] The portion of the insert with a low specific gravity may be aligned with the horizontal center of the club face when the club is at an address position. In another embodiment, the low specific gravity portion may be biased toward either the toe or the heel of the club head.

[0113] Suitable materials for the low specific gravity portion of the insert include, but are not limited to, aluminum, aluminum alloys, magnesium, magnesium alloys, thermoplastics, thermosets, resins, epoxies, bulk molding compound, BMC material, or similar materials and combinations thereof.

[0114] The Adjustment Mechanism

[0115] The adjustment mechanism 328 may take a plurality of forms. For example, while not shown in detail, the adjustment mechanism 328 may be in the form of a series of notches at a receiving point on the body of club head 300 and deformable tabs that are located on the insert 325. Applying force to the insert 325 in the back to face direction causes the tabs to undergo elastic deformation when they come into contact with a notch. As the tab passes a notch the tab returns to its original shape, and the insert is successfully relocated closer to the face. A similar process ensues when the insert is pulled in the face to back direction, resulting in the insert relocated further from the face.

[0116] The adjustment mechanism 328 may also be in the form of a series of telescoping steps housed on the interior of the club head 300. For example, when insert 325 is compressed or pulled, the steps act similar to sections of a telescope, sliding past the next step allowing for the extension and compression of the insert in the face to back direction. The steps may be immobilized by a locking mechanism when insert 325 is at a desired location.

[0117] In another embodiment, adjustment mechanism 328 takes the form of a track and roller combination. For example, insert 325 may be coupled to a roller that is, in turn, located on a track. When the locking mechanism is disengaged, the golfer may simply slide insert 325 in toward the face or pull insert 325 away from the face to achieve the desired dimensions.

[0118] In still another embodiment, adjustment mechanism 328 may take the form of a receiving member located inside the club head and an elastically deformable portion of insert 325 folds similar to an accordion. When compressed, the accordion portion folds in on itself at regular intervals allowing insert 325 to move toward the face. When pulled, the deformable portion stretches to allow for insert 25 to move away from the face. In this aspect, the deformable portion may include less than about 10 percent of the total volume of insert 25. For example, in one embodiment, the deformable portion accounts for less than about 5 percent of the total volume of insert 325.

[0119] In yet another embodiment of the invention, the insert 325 may have a section that is elastically deformable. This deformable section engages a receiving portion on the club head that is tapered toward the face. Applying pressure from the back of the club toward the face results in the deformable section of the insert squeezing into the tapered section of the groove, and the insert is moved toward the face. Locking mechanism 330 keeps the deformable section from expanding back to its original length. Removing or loosening the locking mechanism allows for the deformable section to expand toward its original form, pushing the insert away from the face.

[0120] In another embodiment, one or more screws or other movement limiting fasteners may be used to adjust insert 325. For example, a screw may be received by a receiving member located inside the club head. Tightening the screw pulls the insert closer to the face. Alternatively, loosening the screw moves insert 325 further from the face. This adjustment mechanism has the added benefit of not requiring a locking mechanism.

[0121] In another embodiment shown in FIGS. 22-24, insert 325 is coupled to a center pin 350. The insert is preferably round and capable of rotation about center pin 350. Center pin 350 may be coupled to track 360 or similar device that allows for mobility in the face to back dimension. The track may have a locking mechanism, such as a set screw, that prevents the center pin from moving.

[0122] As shown in FIG. 23, insert 325 is made up of a portion 325a and portion 325b, where the portions 325a and 325b have different specific gravities. For example, 325a may have a higher specific gravity than the remainder of the insert and, more specifically, portion 325b. In addition, 325a may have a higher specific gravity than the body of the club head. The low specific gravity portion may account for at least about 50 percent of the total volume of the insert. In one embodiment, the low specific gravity portion makes up at least about 75 percent of the total volume of the insert. The low specific gravity portion 325b may have a specific gravity of less than about 4, preferably less than about 3, and more preferably less than about 2. In this aspect of the invention, the high specific gravity portion 325a has a specific gravity greater than about 5, preferably greater than about 7, and most preferably greater than about 9. The golfer may rotate the insert to position the high specific gravity portion as desired.

[0123] In the alternative, the insert 325 is made up of a portion 325a and portion 325b, where the portion 325a has a lower specific gravity than the remainder of the insert and, more specifically, portion 325b. In addition, 325a may have a lower specific gravity than the body of the club head. The low specific gravity portion 325a may account for about 30 percent or less of the total volume of the insert. In one embodi-

ment, the low specific gravity portion makes up at least about 20 percent of the total volume of the insert. The low specific gravity portion **325a** may have a specific gravity of less than about 4, preferably less than about 3, and more preferably less than about 2. In this aspect of the invention, the high specific gravity portion **325b** has a specific gravity greater than about 7, preferably greater than about 9. The golfer may rotate the insert to position the low specific gravity portion as desired.

[0124] In another embodiment, shown generally in FIG. 25, two separate movable inserts may be coupled to the body by a rotatable hinge. For example, FIG. 25 shows inserts **375a** and **375b** attached to the inside of the body of the club **300** by hinges **380a** and **380b**. The hinge is lockable by the use of a locking mechanism such as a screw or other movement limiting fastener. Inserts **375a** and **375b** are able to move into the body of the club as desired by the golfer along the axis of hinge **380a** and **380b**. Dotted lines **390a** and **390b** indicate the position of the inserts **375a** and **375b** when fully compressed into the body.

[0125] In still another embodiment, insert **325** is removable. In this embodiment, the golfer is free to choose an insert configuration that conforms to his swing type. For example, a golfer may not wish to have a weighted insert, but would still prefer the option of maximizing the front to back dimension of the club head. In this aspect of the invention, the golfer would be able to select an insert formed solely from a low specific gravity material to allow for the maximization without adding significant weight to any part of the club. In another embodiment, the golfer may desire an insert with a particular mass distribution. For example, inserts may be weighted toward the heel or the toe.

[0126] The adjustable insert may be capable of a wide range of movement. For example, in one aspect of the invention the insert is capable of movement in less than about 0.05 inch increments. In another embodiment the insert is capable of movement in less than about 0.01 inch increments. The ability to move the insert in small increments allows the user to reach a target front to back distance with a higher precision.

The Locking Mechanism

[0127] Like the adjustment mechanism, locking mechanism **330** may take a variety of forms. For example, the locking mechanism may take the form of a screw. In this aspect of the invention, when the screw is turned in the particular direction, e.g., clockwise, it may act as a barrier to prevent the adjustment mechanism from moving.

[0128] In another embodiment, the locking mechanism may take the form of a peg that, when inserted into the adjustment mechanism, prevents movement of the adjustment mechanism. One of ordinary skill in the art would appreciate that there are many methods for preventing the movement of the adjustment mechanism that would be sufficient for use with the adjustable insert of the present invention. For example, screws, pegs, pins, clips, and other similar adjustable fasteners are all useful as locking mechanisms.

[0129] Preferably, the locking mechanism is accessed at a point on the bottom of the club to preserve the aesthetic quality of the club. Additionally, the locking mechanism may only be engaged through the use of a specialized tool designed specifically for use with the locking mechanism.

Spray Coating

[0130] As an alternative to or in combination with the weighted inserts and adjustable inserts above, any portion of

the club head of the invention may be treated with a thermal or combustion spray coating to alter the weight distribution of the club head.

[0131] For example, certain designated portions of the golf club designed to have a high specific gravity may be spray coated according to this aspect of the invention. Examples of suitable materials for the spray include, but are not limited to, aluminum-oxide powders, tungsten-carbide powders, molybdenum based powder, tungsten powders, or similar materials and combinations thereof. In addition, various portions of the club head may have a spray coating from a first material and other various portions with a second material. The spray coating may be applied such that there are at least three portions of the club head sprayed with different coatings.

[0132] The specific gravity of the spray coating may be at least about 7. In one embodiment, the specific gravity of the spray coating is greater than about 9. In another embodiment, the specific gravity of the spray coating is greater than about 12.

[0133] The portions of the club head that are spray coated may be sprayed prior to assembly, after partial assembly, or post assembly. For example, the spray coating may be applied only to the interior of the club head. As such, if the club head is formed from multiple components, as described above, the various components may be spray coated in certain areas prior to assembly. Likewise, if the interior of the club head remains accessible after assembly of most of the components, the spray coating may occur prior to the remainder of the assembly. The spray coating may also be applied to select exterior portions of the club head. For example, the interior or exterior of the skirt of the club may have one or more pockets, depressions, or cavities. A spray coating may be employed to fill the pockets, depressions, or cavities. In one embodiment, portions of the sole, toe and heel of the club head are sprayed with a coating in order to increase the forgiveness of the club head. In another embodiment, a spray coating is applied to the entire exterior of the club head. Alternatively, the spray coating may be applied to the entire interior of the club head. A spray coating may also be applied to every surface of the club except for the face of the club.

[0134] The spray coating may have a thickness ranging from about 10 microns to about 10 mm. In one embodiment, the spray coating is about 0.01 mm to about 5 mm. In another embodiment, the spray coating is about 0.02 mm to about 4 mm. In still another embodiment, the spray coating is about 0.04 mm to about 2 mm. In addition, various portions of the club head may have a spray coating with a first thickness and other various portions with a second thickness. The spray coating may be applied such that there are at least three portions of the interior of the club head with different thicknesses ranging from about 10 microns to about 10 mm.

[0135] Other than in the operating examples, or unless otherwise expressly specified, all of the numerical ranges, amounts, values and percentages such as those for amounts of materials, moments of inertias, center of gravity locations, loft and draft angles, and others in the following portion of the specification may be read as if prefaced by the word "about" even though the term "about" may not expressly appear with the value, amount, or range. Accordingly, unless indicated to the contrary, the numerical parameters set forth in the following specification and attached claims are approximations that may vary depending upon the desired properties sought to be obtained by the present invention. At the very least, and not as an attempt to limit the application of the doctrine of equiva-

lents to the scope of the claims, each numerical parameter should at least be construed in light of the number of reported significant digits and by applying ordinary rounding techniques.

[0136] Notwithstanding that the numerical ranges and parameters setting forth the broad scope of the invention are approximations, the numerical values set forth in the specific examples are reported as precisely as possible. Any numerical value, however, inherently contains certain errors necessarily resulting from the standard deviation found in their respective testing measurements. Furthermore, when numerical ranges of varying scope are set forth herein, it is contemplated that any combination of these values inclusive of the recited values may be used.

[0137] While the preferred embodiments of the present invention have been described above, it should be understood that they have been presented by way of example only, and not of limitation. It will be apparent to persons skilled in the relevant art that various changes in form and detail can be made therein without departing from the spirit and scope of the invention. Thus the present invention should not be limited by the above-described exemplary embodiments, but should be defined only in accordance with the following claims and their equivalents. Furthermore, while certain advantages of the invention have been described herein, it is to be understood that not necessarily all such advantages may be achieved in accordance with any particular embodiment of the invention. Thus, for example, those skilled in the art will recognize that the invention may be embodied or carried out in a manner that achieves or optimizes one advantage or group of advantages as taught herein without necessarily achieving other advantages as may be taught or suggested herein. U.S. Design Pat. No. D567,888, is incorporated herein by reference.

What is claimed is:

1. A golf club head comprising:

a body having a first specific gravity defined by a face, a back, a heel, a toe, a sole, a crown, and at least one adjustable insert, wherein the adjustable insert is capable of movement in the face to back direction and locking into at least one position;

wherein the club head has a first distance from the toe to the heel;

wherein the club head has a second distance from the face to the back without the adjustable insert;

wherein the club head has a third distance from the face to the back of the adjustable insert comprising the insert extended to a maximum in the face to back direction; and

wherein the adjustable insert further comprises a first adjustment mechanism and a first locking mechanism.

2. The golf club head of claim 1, wherein the adjustable insert comprises a first portion with a second specific gravity greater than the first specific gravity.

3. The golf club head of claim 2, wherein the second specific gravity is about 7 or more.

4. The golf club head of claim 2, wherein the first portion is less than about 40 percent of the total volume of the adjustable insert.

5. The golf club head of claim 4, wherein the first portion is less than about 20 percent of the total volume of the adjustable insert.

6. The golf club head of claim 2, wherein the first portion of the adjustable insert is located substantially on the heel side of the club.

7. The golf club head of claim 2, wherein the first portion of the adjustable insert is located substantially on the toe side of the insert.

8. The golf club head of claim 2, wherein the adjustable insert comprises a second portion with a third specific gravity less than the first specific gravity.

9. The golf club head of claim 8, wherein second portion has a specific gravity less than about 4.

10. The golf club head of claim 1, wherein the third distance is greater than about 5 inches.

11. The golf club head of claim 1, wherein the third distance is greater than or equal to the first distance times 1.10.

12. The golf club head of claim 1, wherein the third distance is greater than or equal to the first distance times 1.05.

13. The golf club head of claim 1, wherein the third distance is greater than or equal to the first distance times 1.00.

14. The golf club of claim 1, wherein the adjustment mechanism comprises a plurality of notches located on the body of the club head and a deformable tab located on the adjustable insert and designed to fit within a notch.

15. The golf club of claim 1, wherein the adjustable insert is rotatable about a center axis.

16. The golf club of claim 15, wherein the adjustable insert further comprises a first portion and a second portion, the second portion has a specific gravity greater than the first portion, and the second portion comprises up to about 30 percent of the total volume of the adjustable insert.

17. The golf club head of claim 1, wherein the third distance is greater than or equal to 1.05 times the second distance.

18. The golf club head of claim 1, wherein the third distance is greater than or equal to 1.50 times the second distance.

19. The golf club head of claim 1, wherein the insert is capable of movement in increments of less than about 0.05 inch.

* * * * *