



(19) **United States**

(12) **Patent Application Publication**
Noble et al.

(10) **Pub. No.: US 2010/0029402 A1**

(43) **Pub. Date: Feb. 4, 2010**

(54) **GOLF CLUBS WITH VARIABLE MOMENT OF INERTIA AND METHODS OF MANUFACTURE THEREOF**

(21) Appl. No.: **12/184,022**

(22) Filed: **Jul. 31, 2008**

(76) Inventors: **Randall B. Noble**, Phoenix, AZ (US); **Jeff A. Blankenship**, Phoenix, AZ (US); **Eric V. Cole**, Phoenix, AZ (US)

Publication Classification

(51) **Int. Cl.**
A63B 53/06 (2006.01)

(52) **U.S. Cl.** **473/291; 473/335; 473/349; 473/346; 29/428**

Correspondence Address:
KARSTEN MANUFACTURING CORPORATION
LEGAL DEPARTMENT
2201 WEST DESERT COVE
PHOENIX, AZ 85029 (US)

(57) **ABSTRACT**

Embodiments of golf clubs with variable moment of inertia and methods of manufacture thereof are described herein. Other embodiments and related methods are disclosed herein

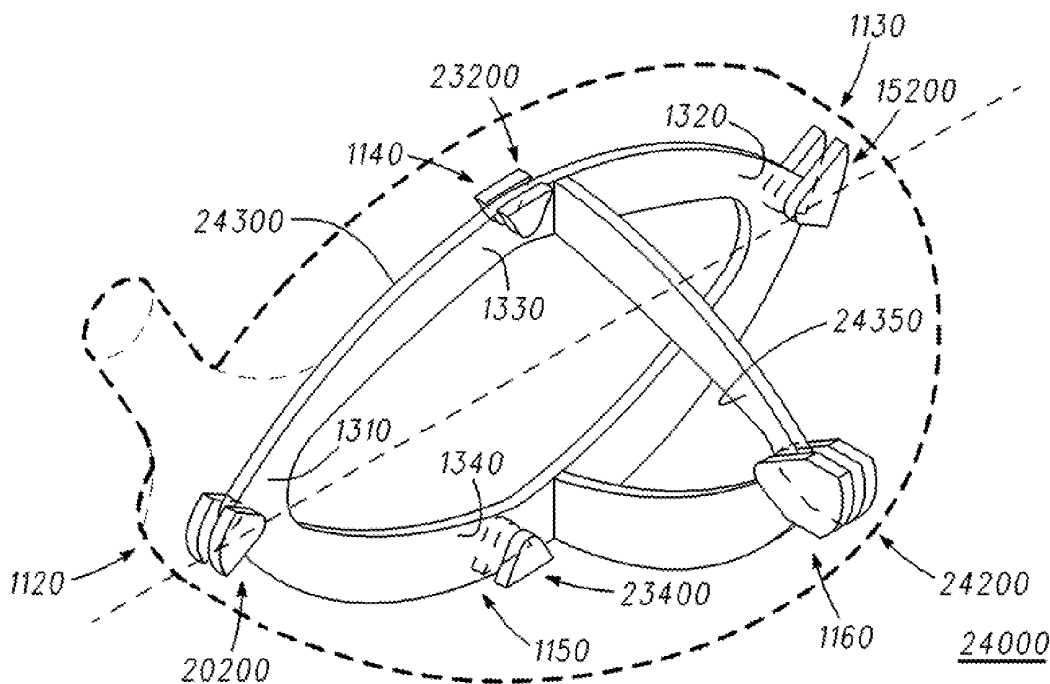

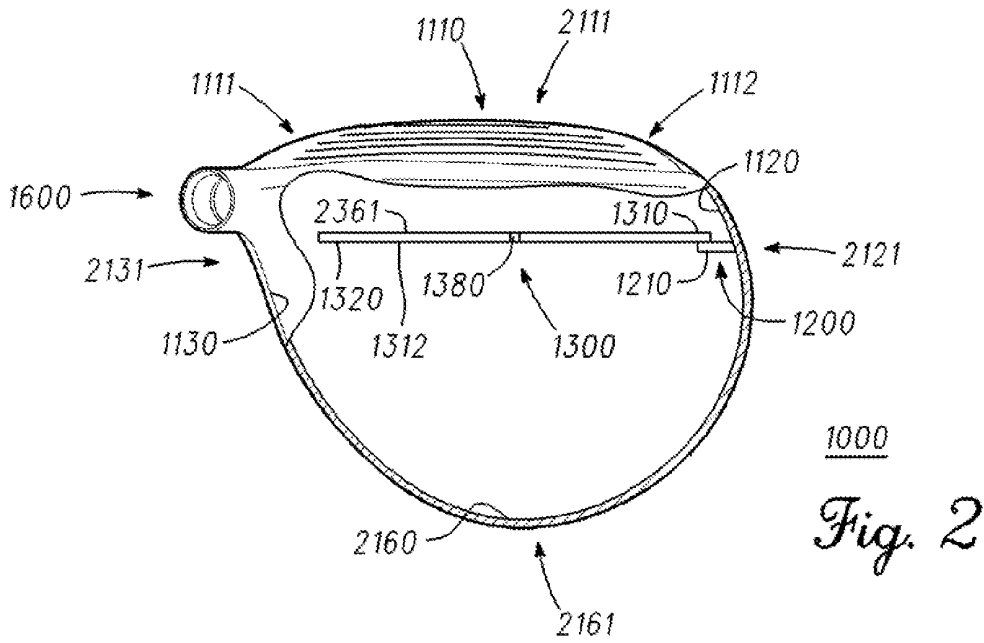
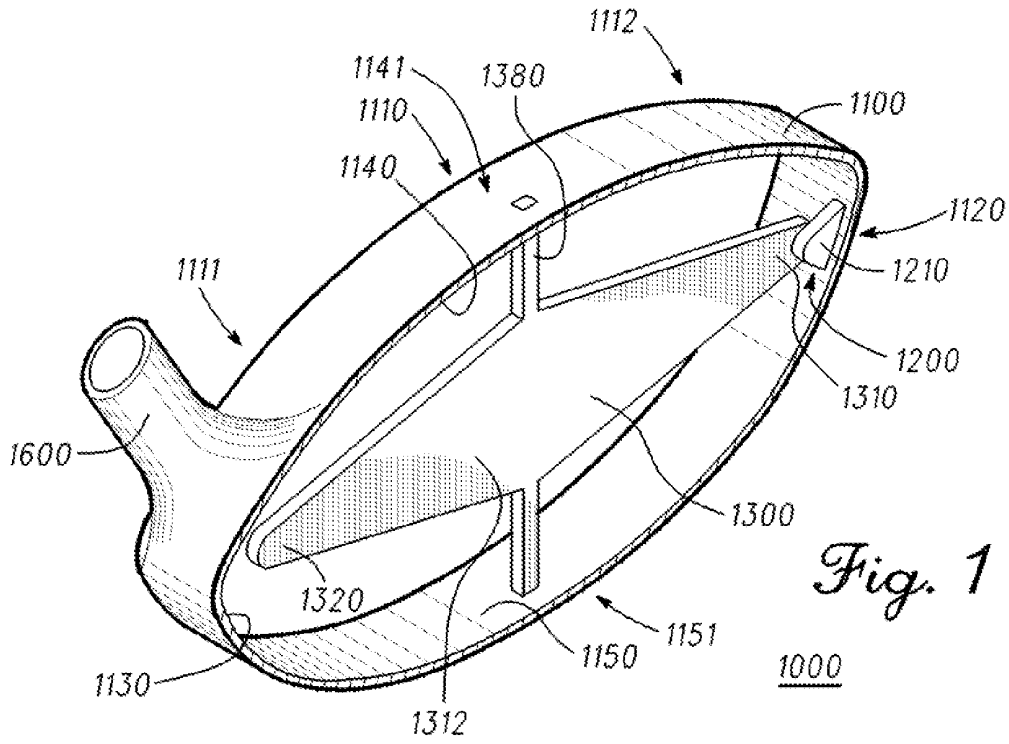

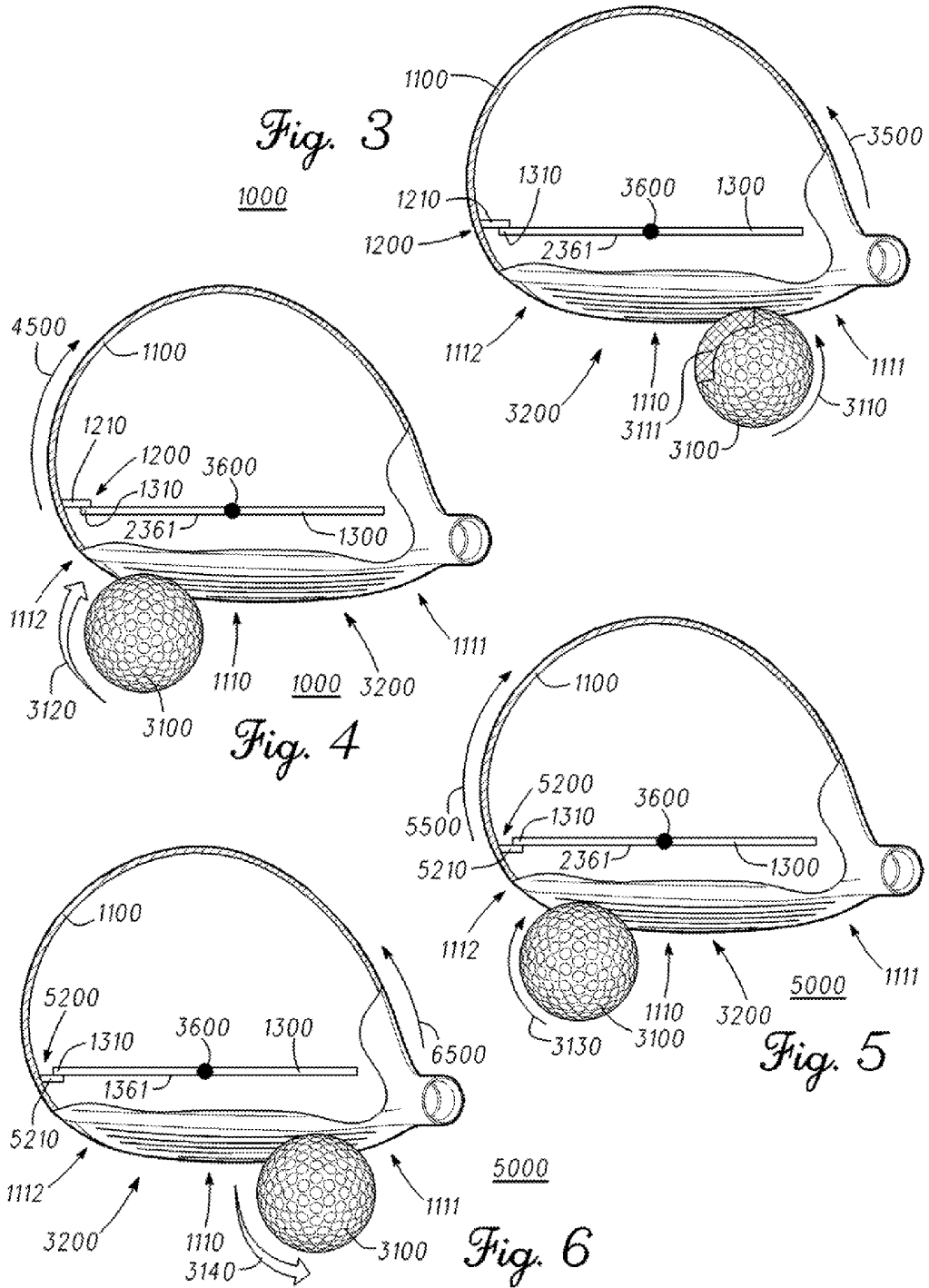

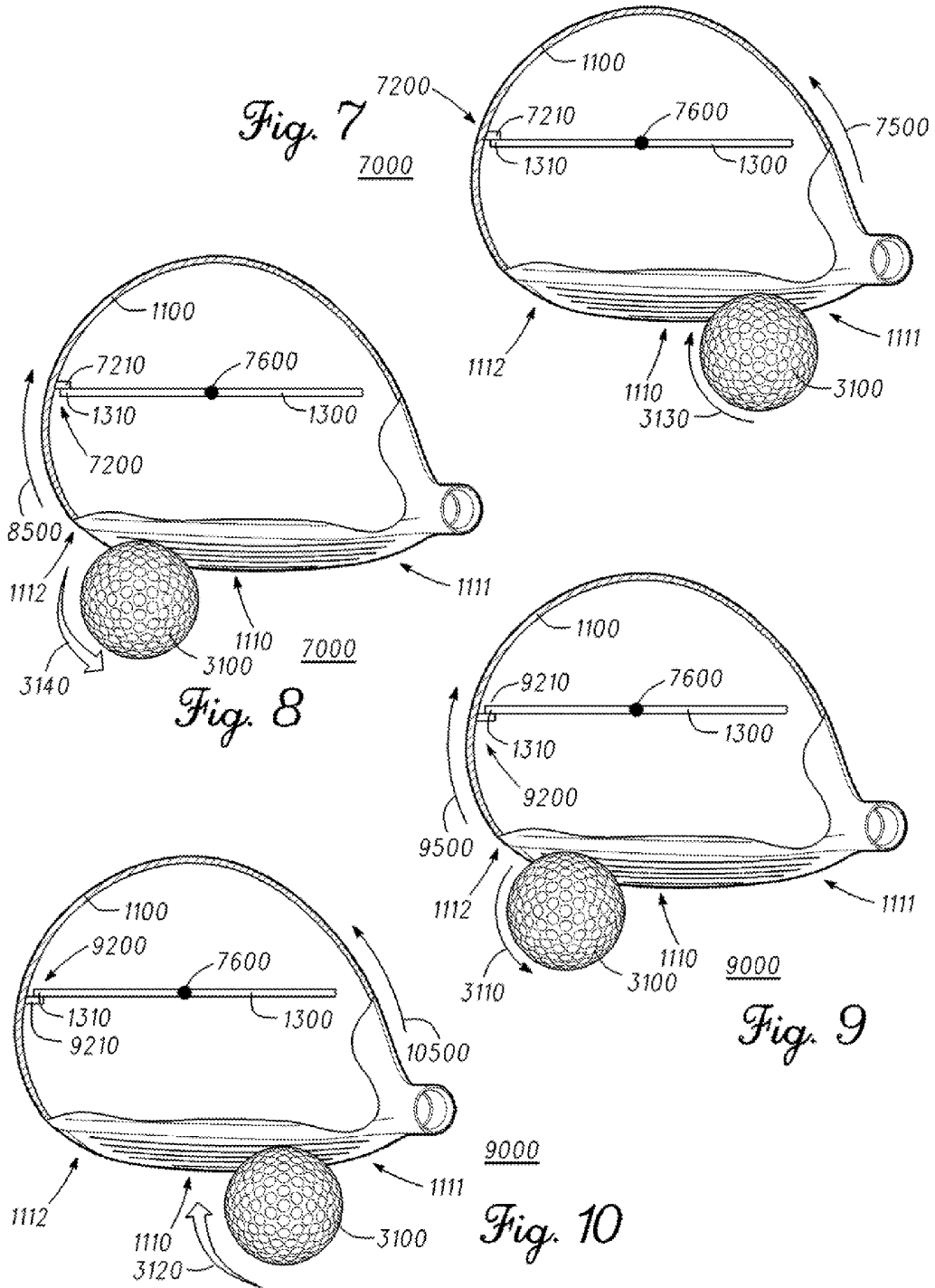

Fig. 11

11000

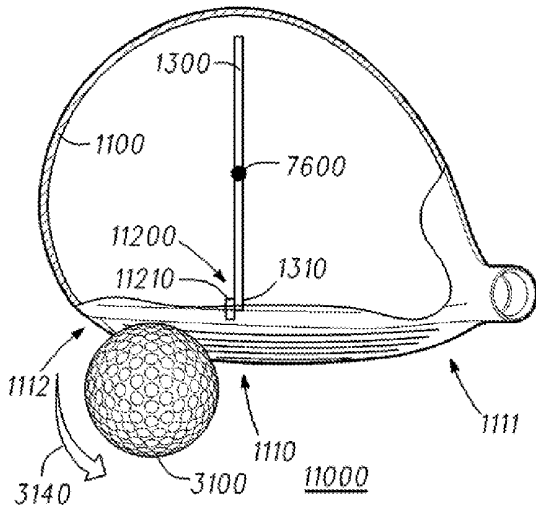
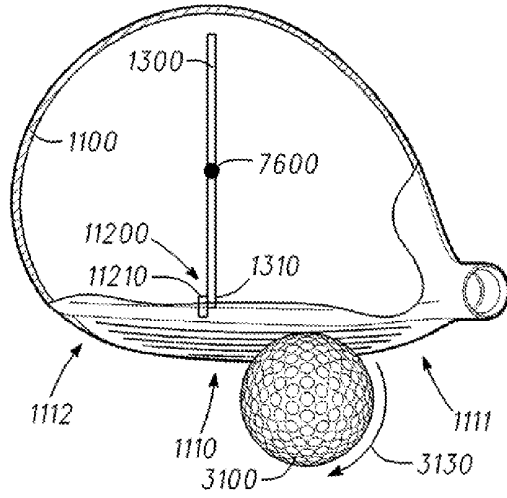

Fig. 12

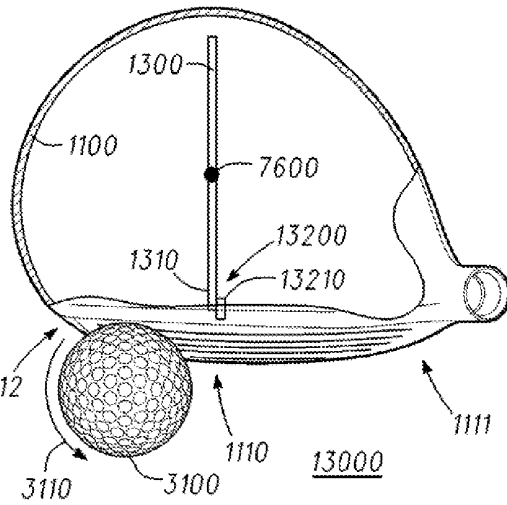
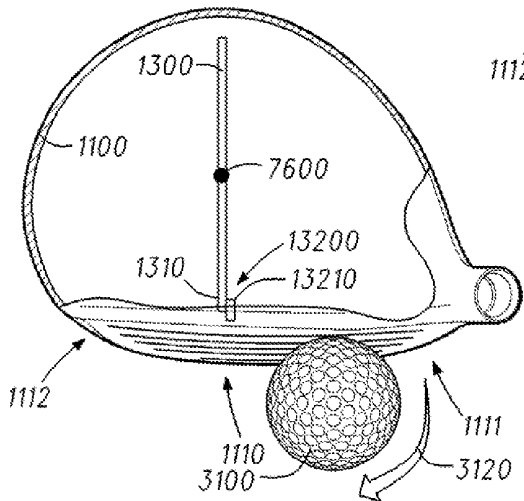
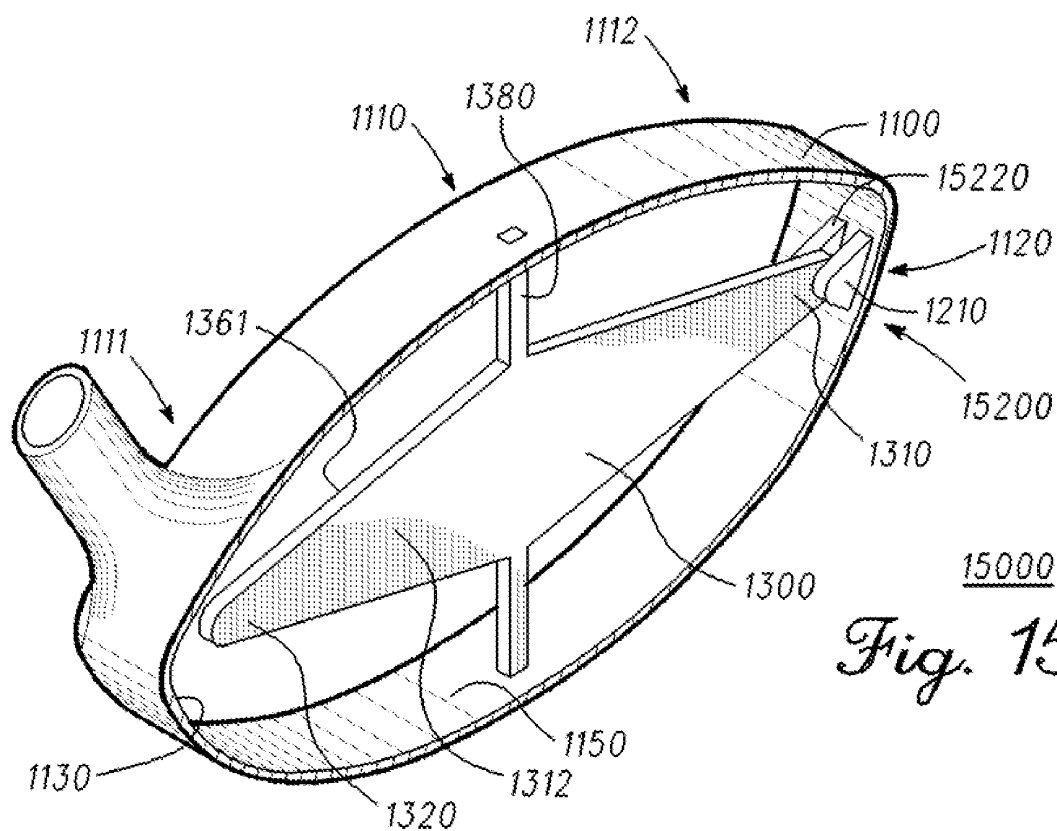

Fig. 13



13000
Fig. 14



15000
Fig. 15

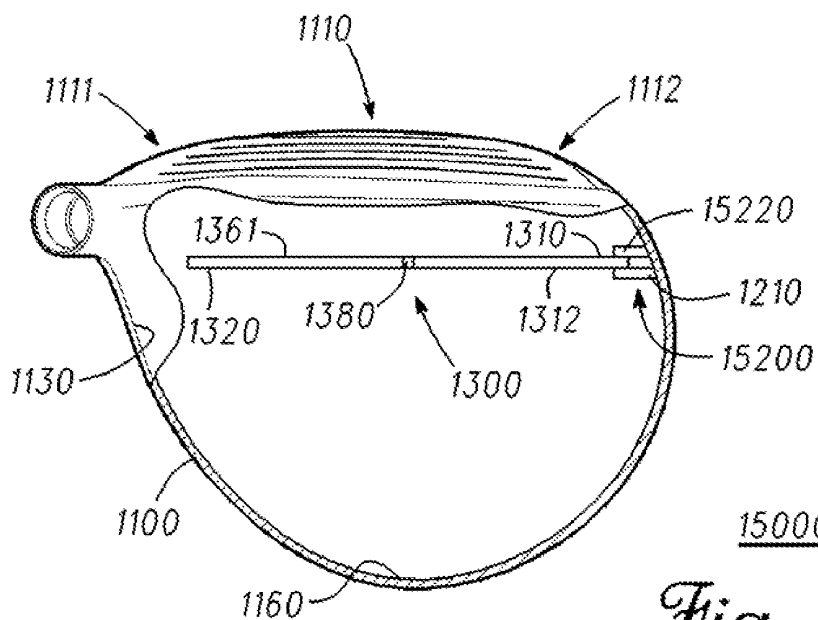

15000
Fig. 16

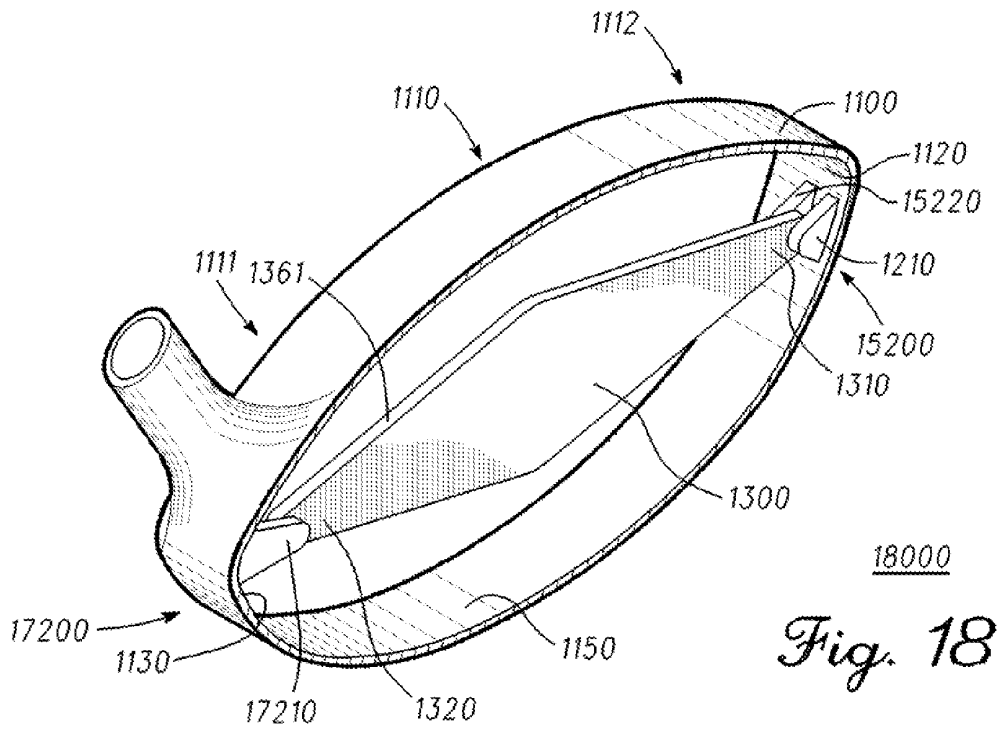
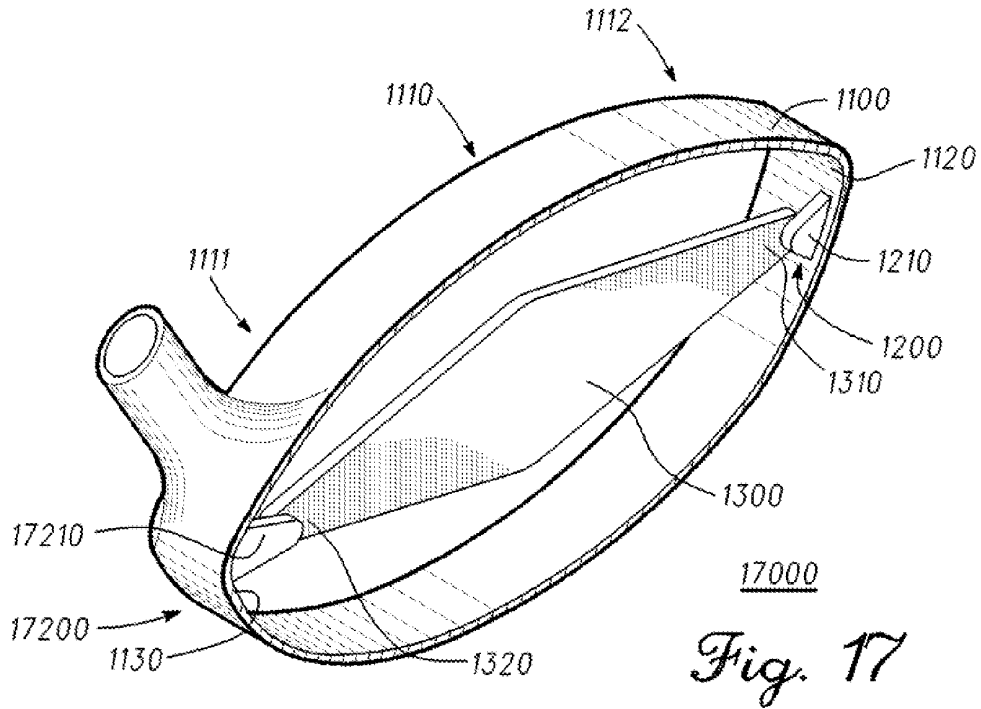

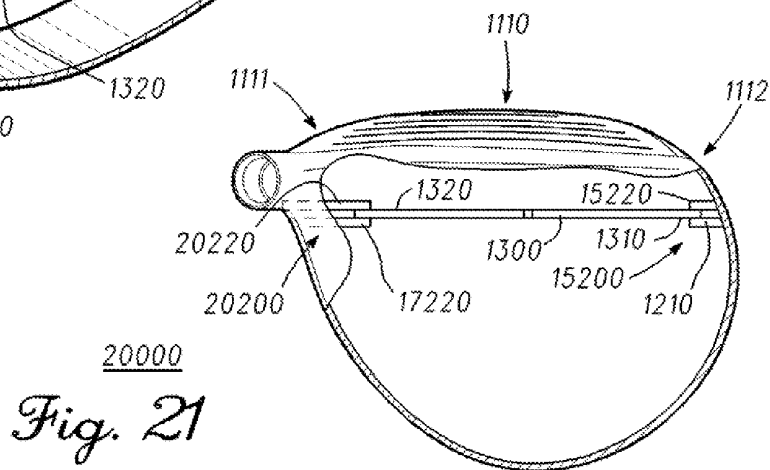
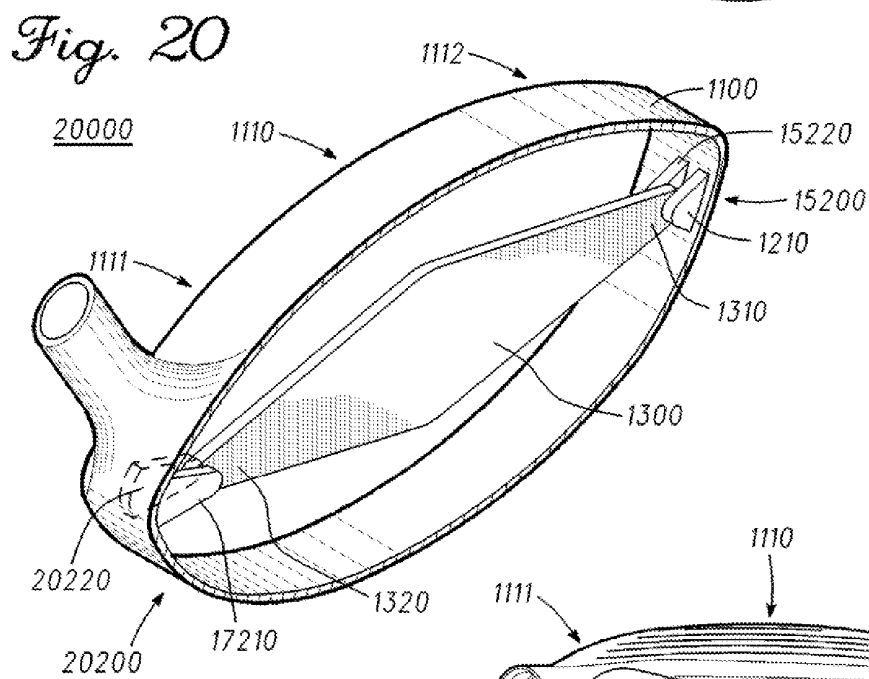
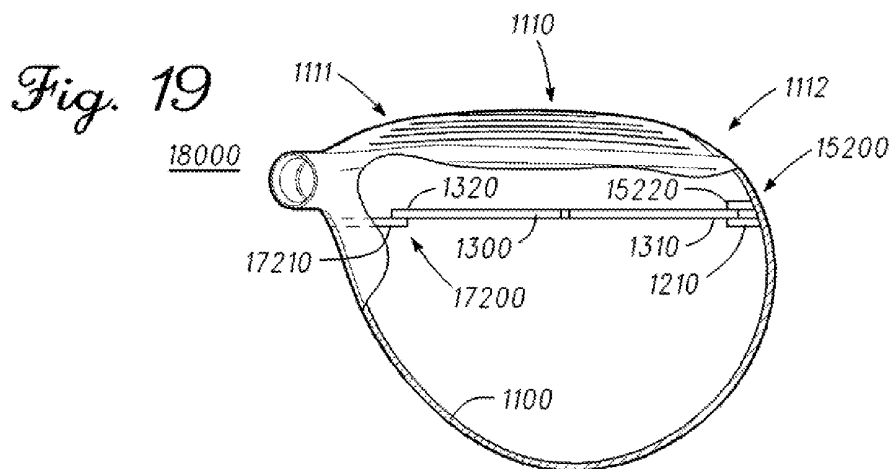

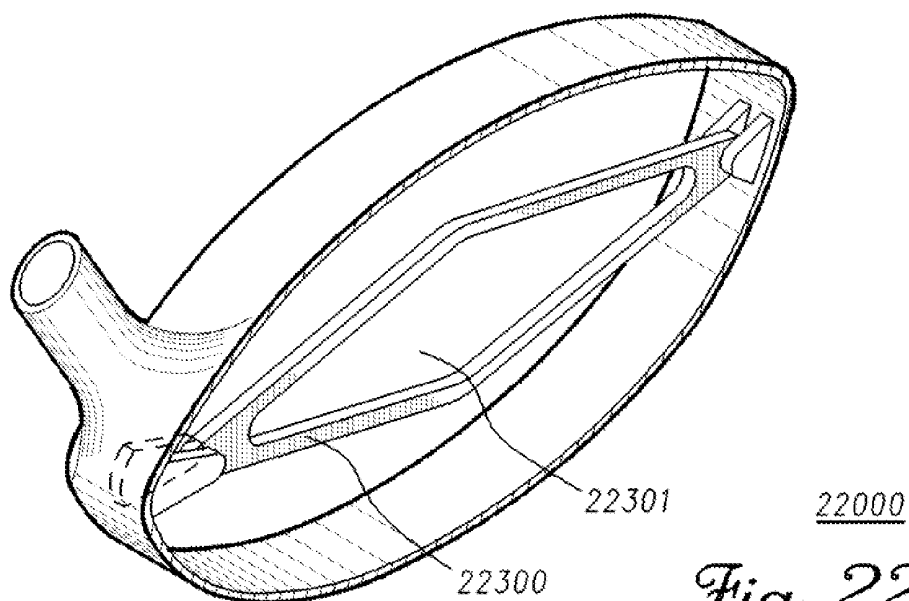

Fig. 22

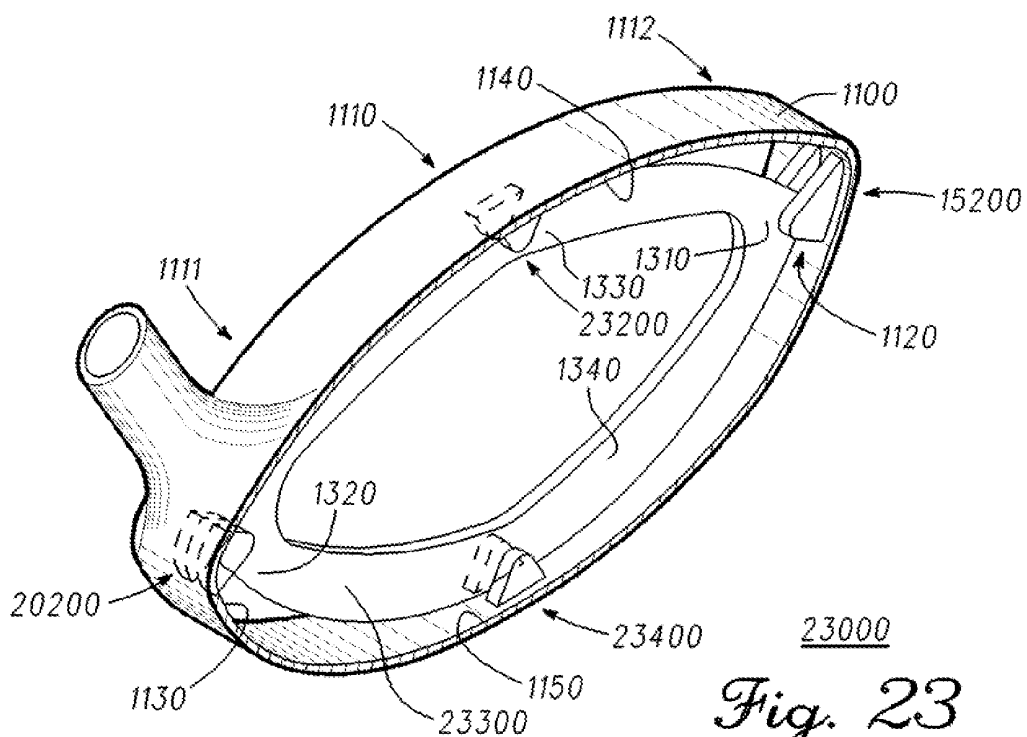

Fig. 23

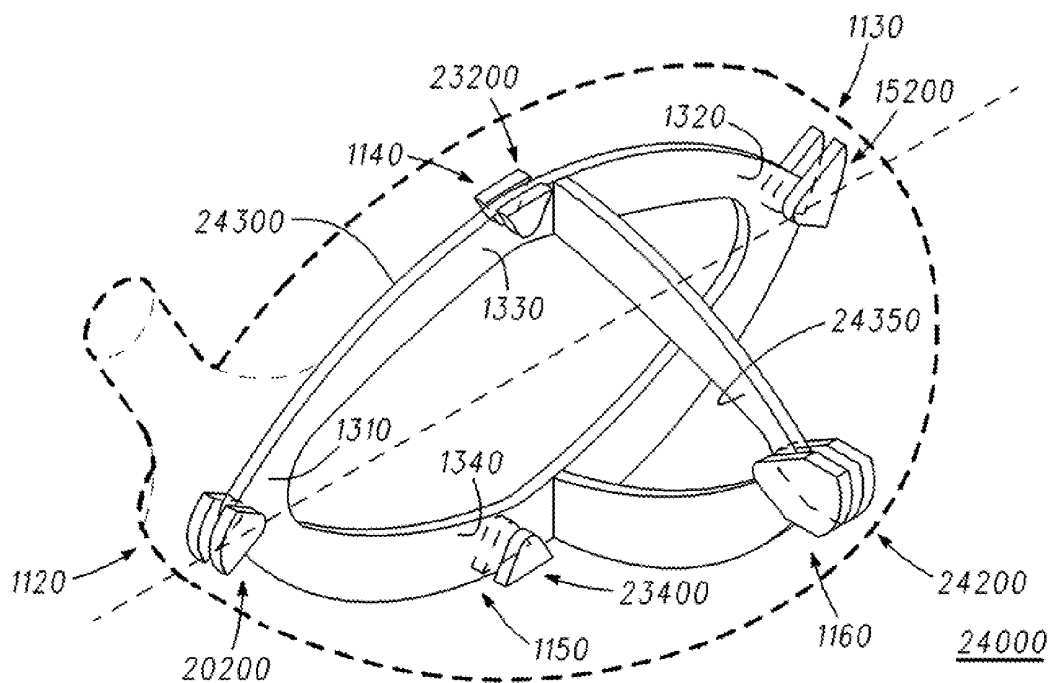

Fig. 24

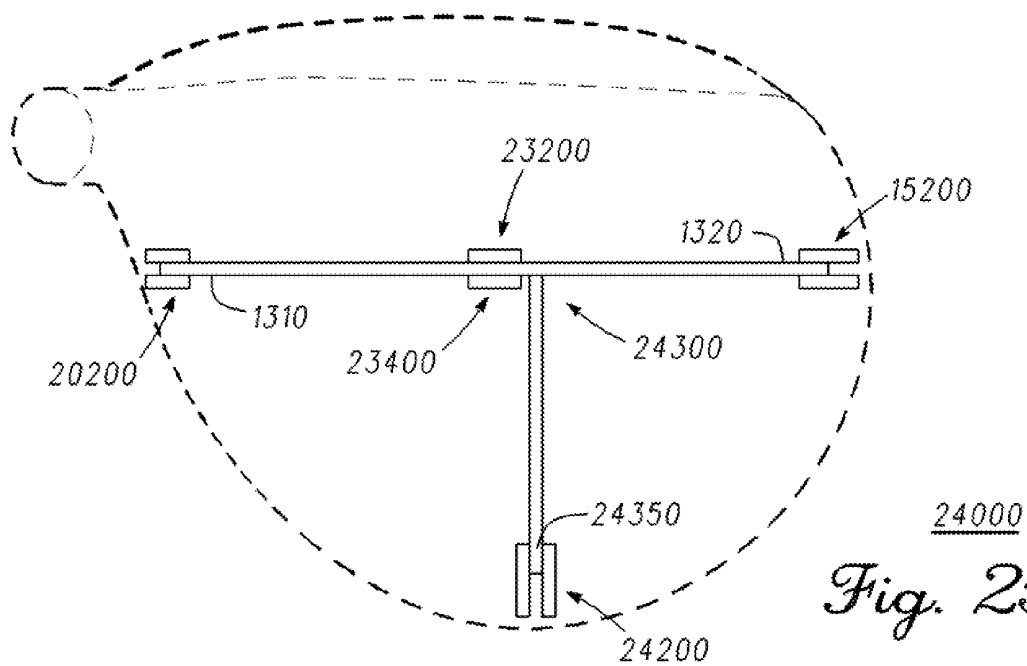

Fig. 25

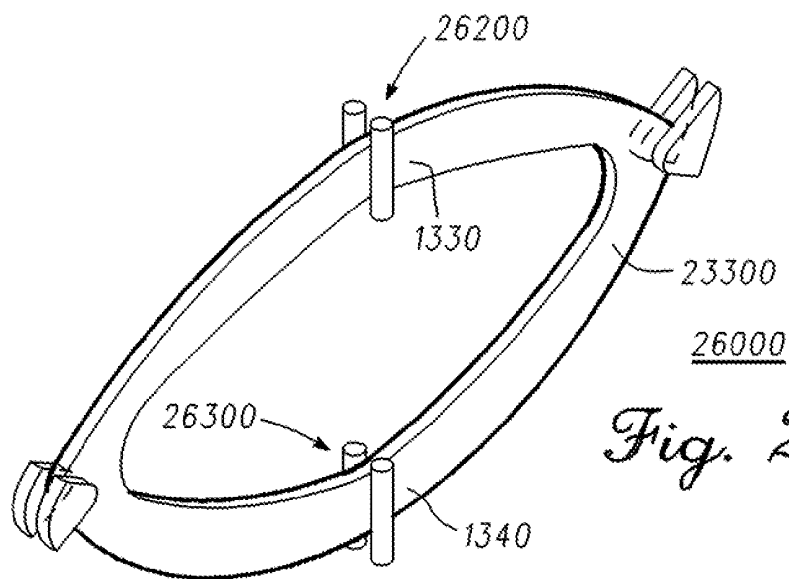

Fig. 26

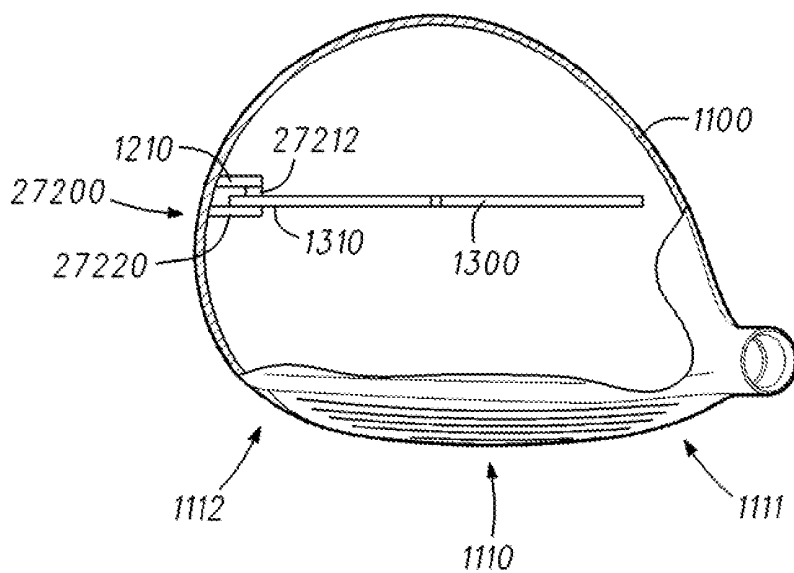

Fig. 27

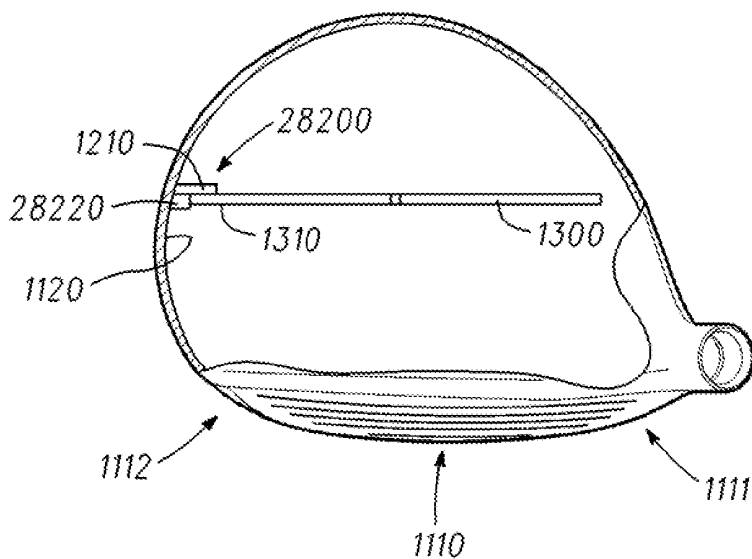
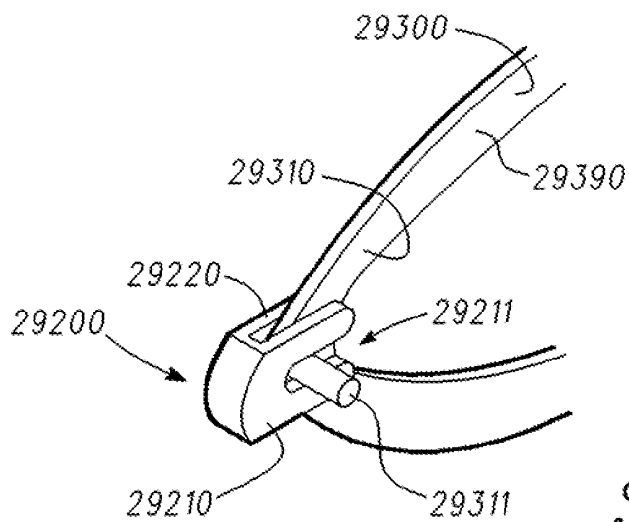

Fig. 28

28000



29200

Fig. 29

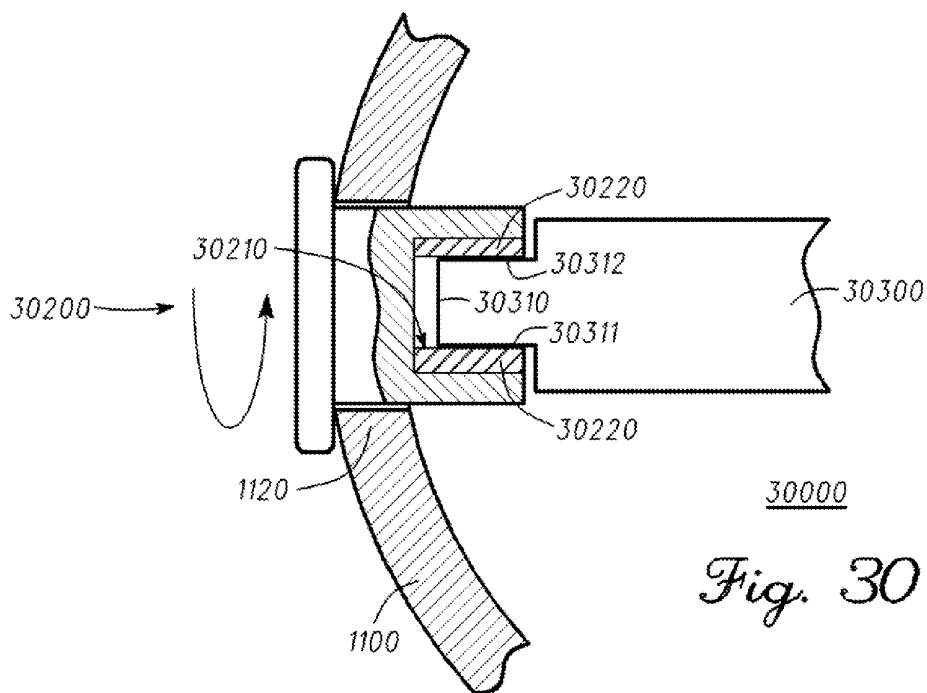

Fig. 30

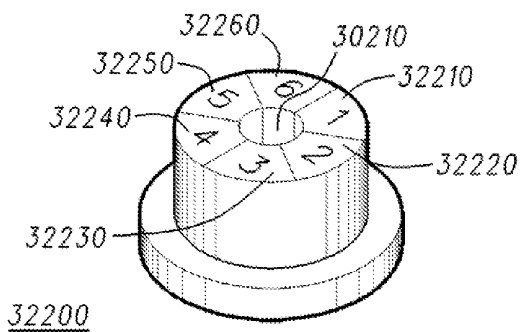

Fig. 32

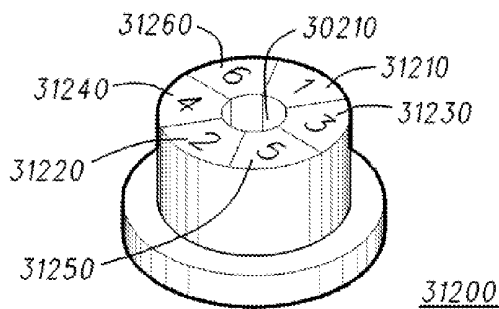
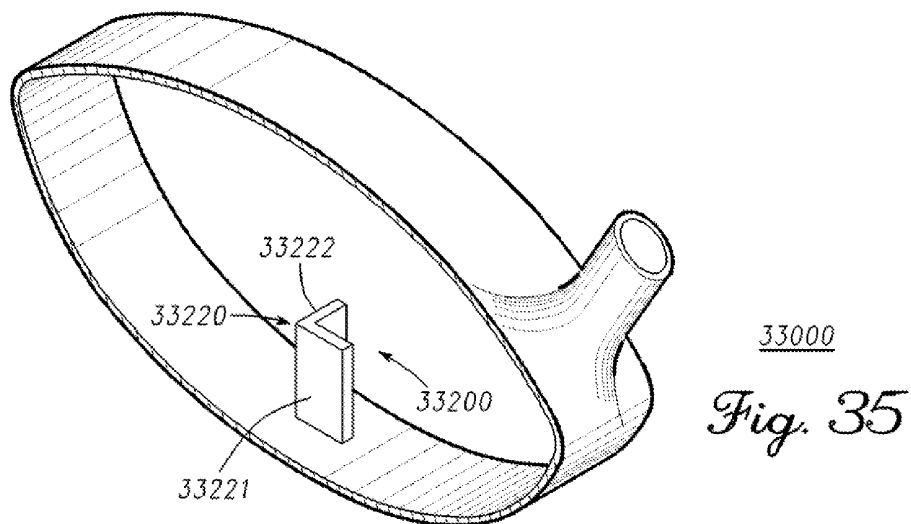
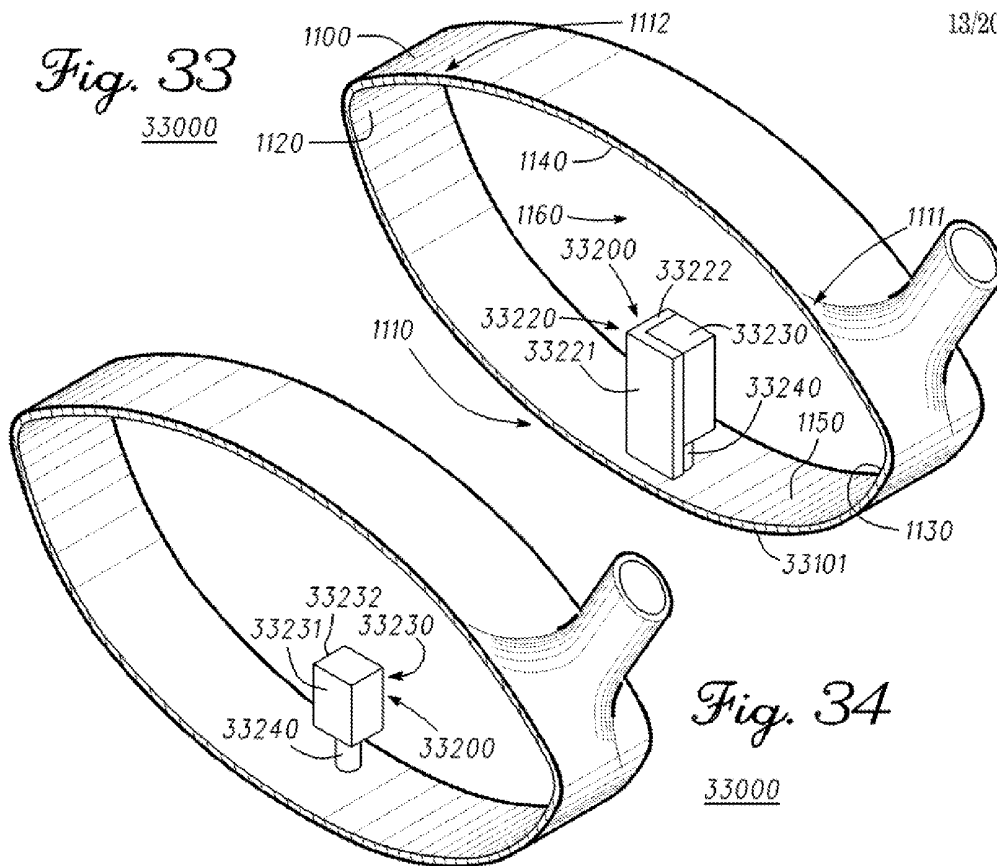
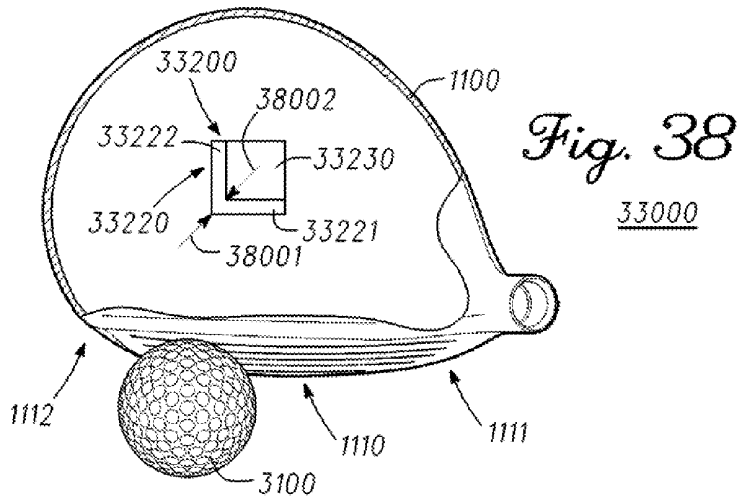
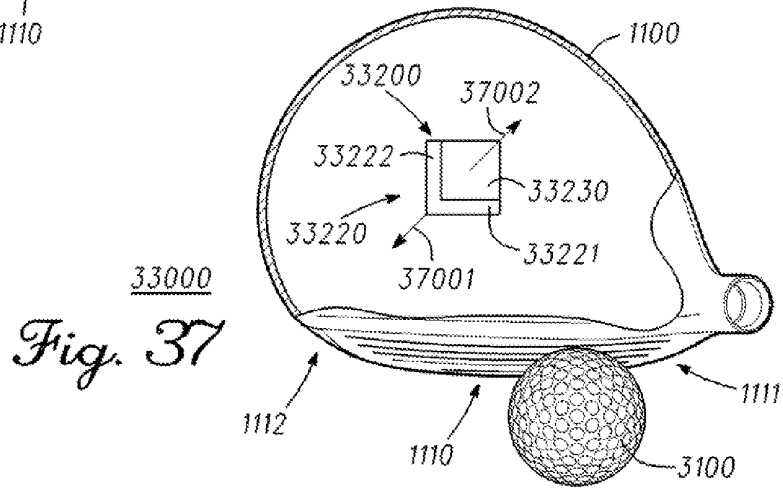
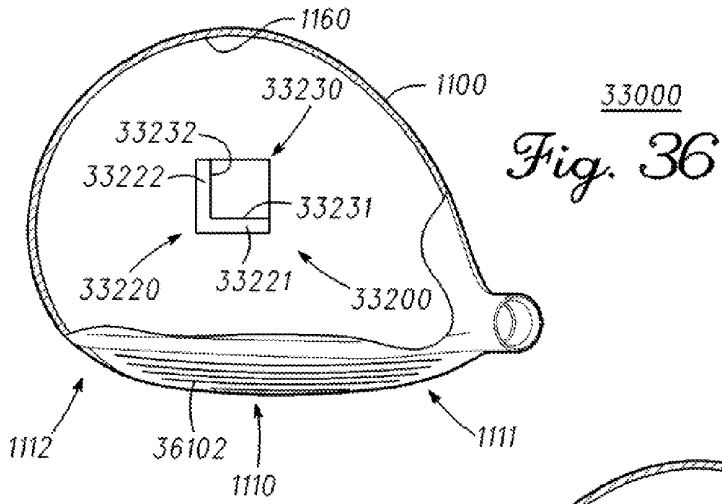
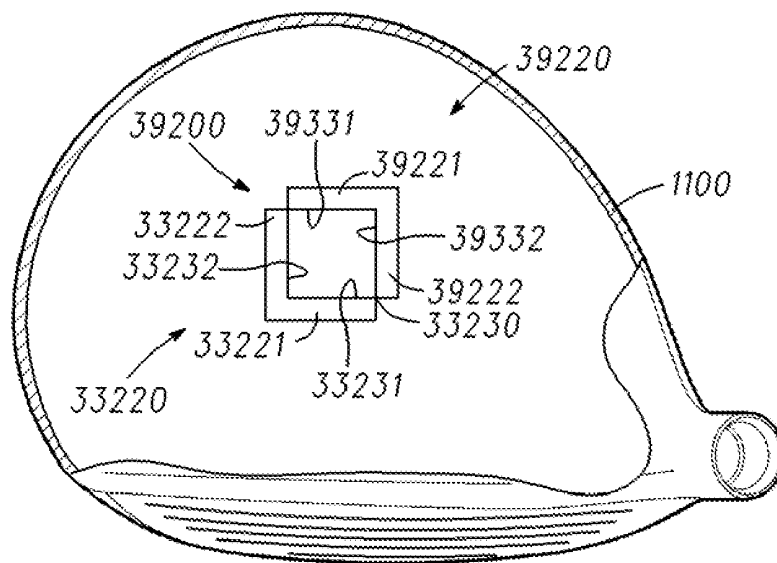

Fig. 31







39000

Fig. 39

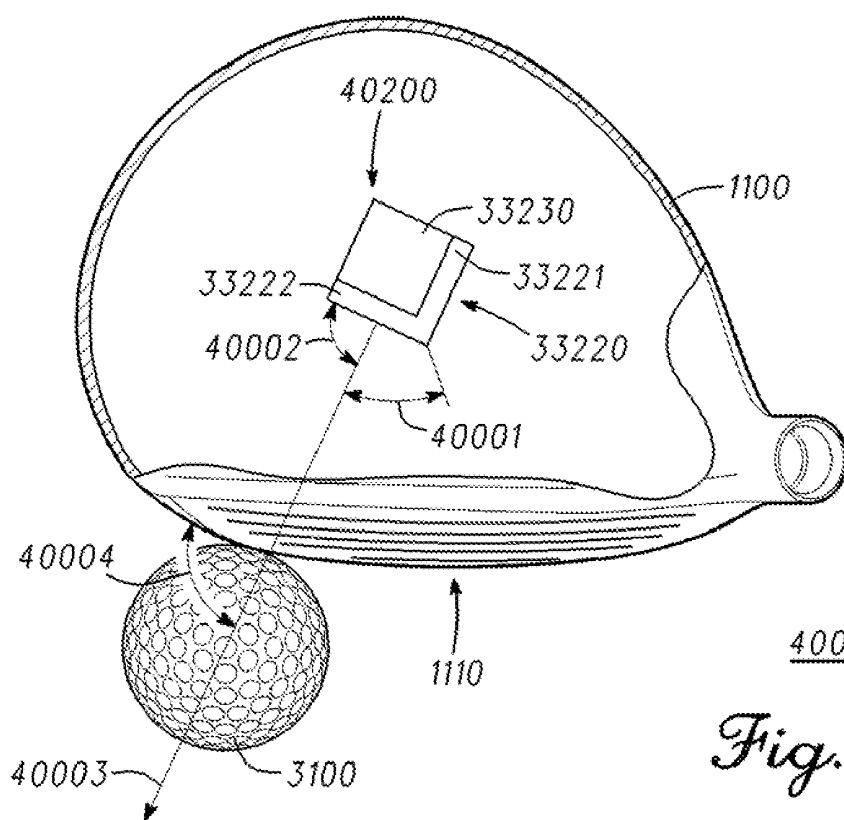

40000

Fig. 40

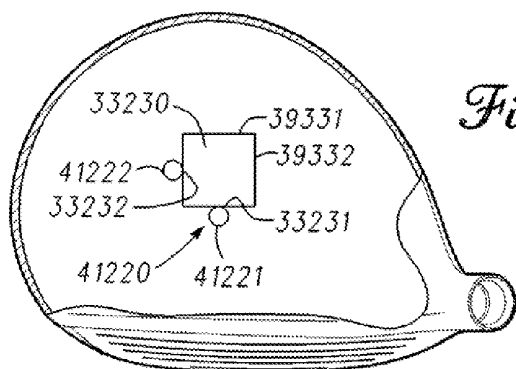

Fig. 41

41000

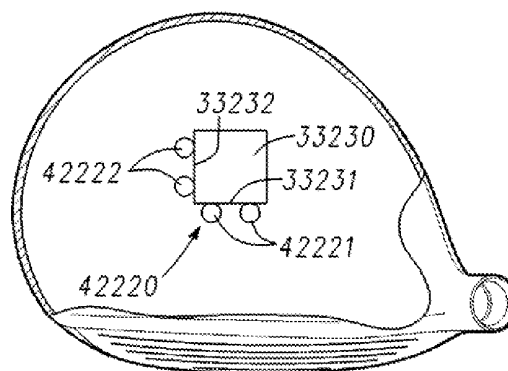

Fig. 42

42000

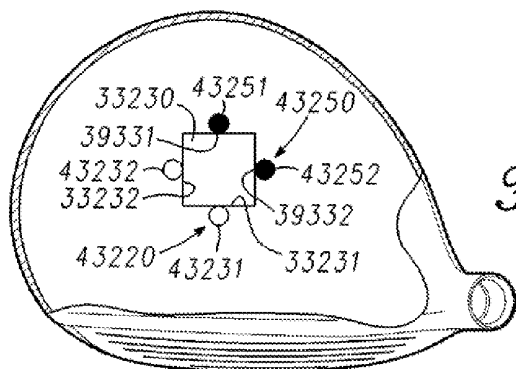

Fig. 43

43000

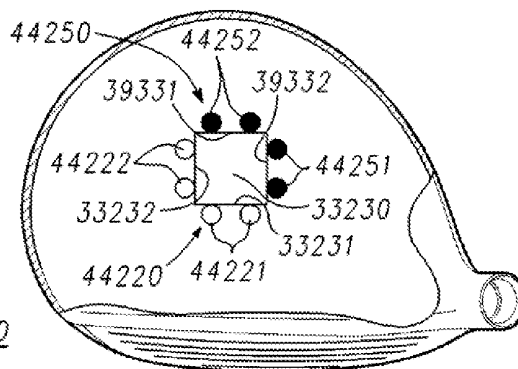

Fig. 44

44000

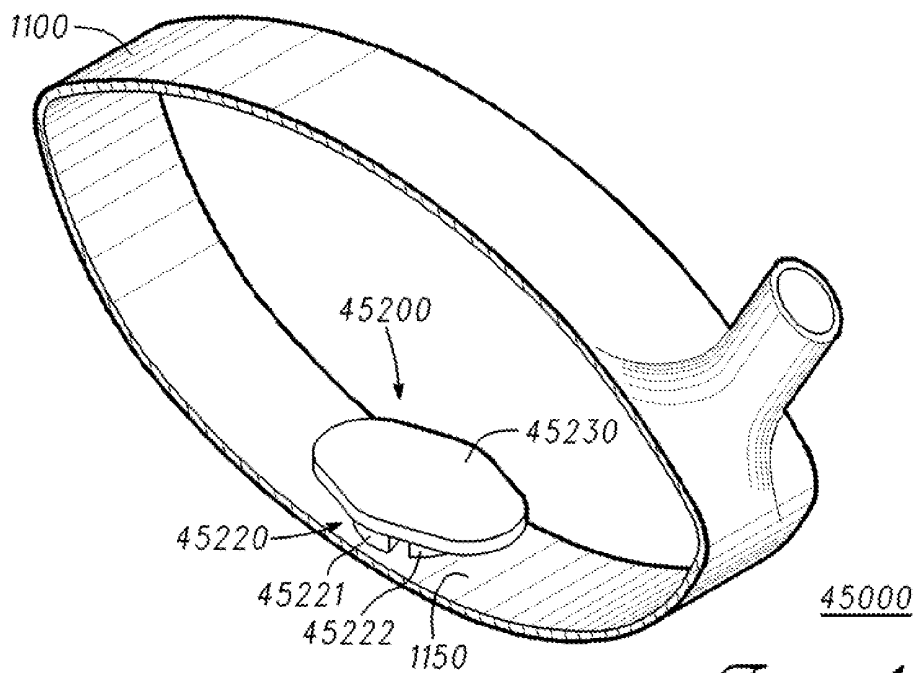

Fig. 45

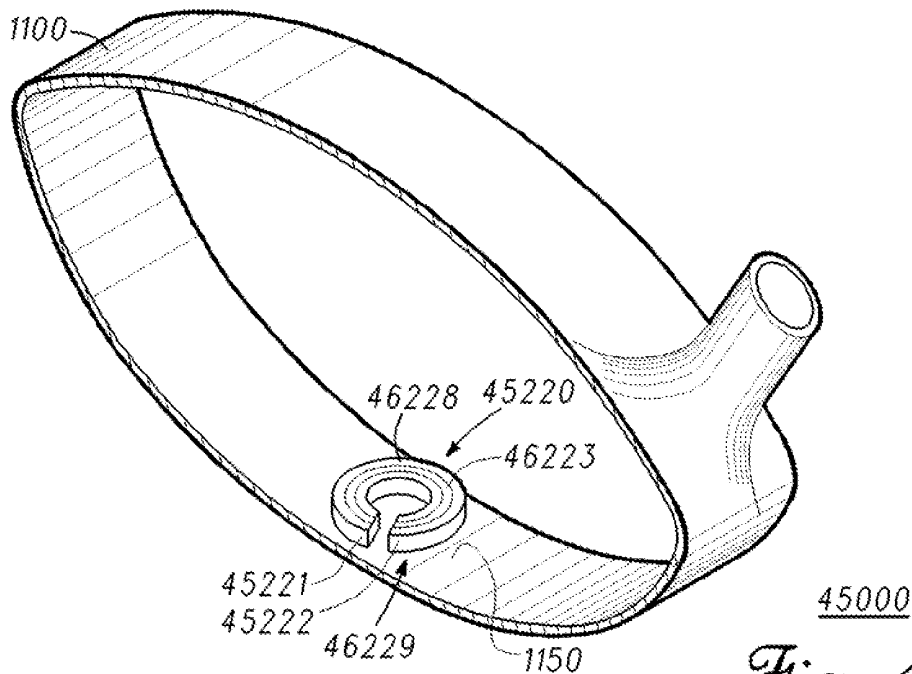

Fig. 46

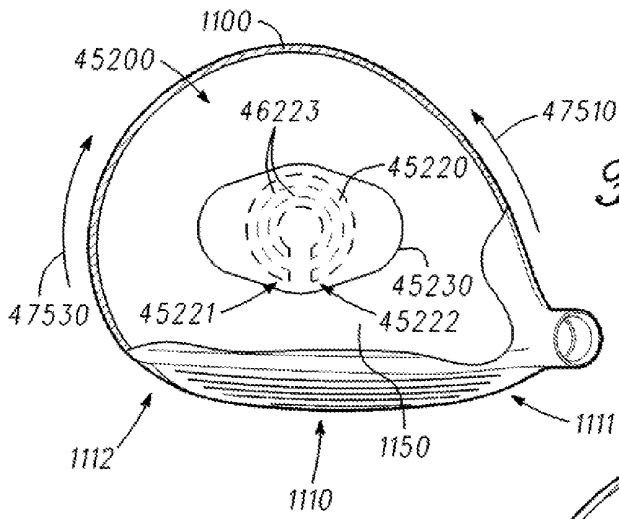

Fig. 47

45000

Fig. 48

48000

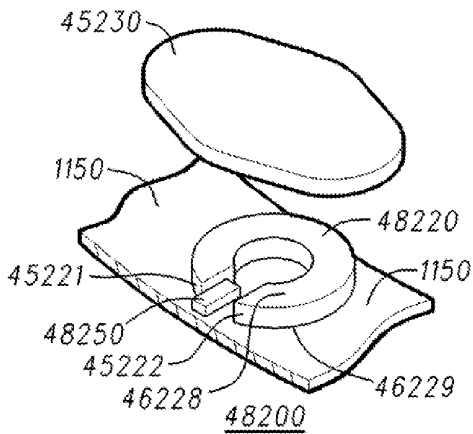
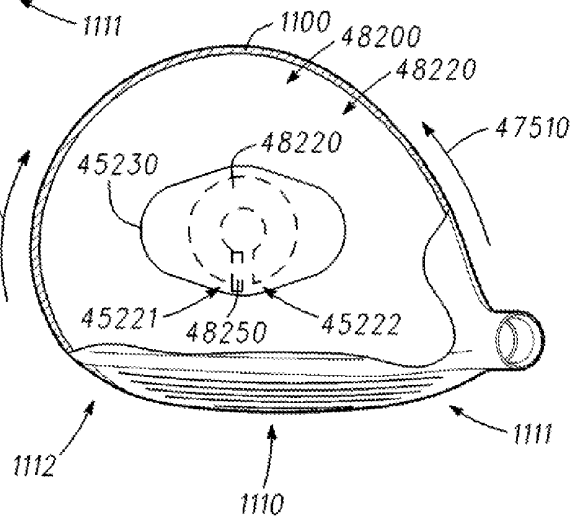
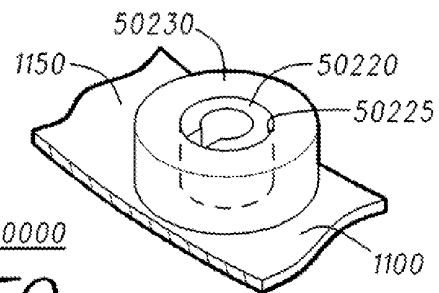
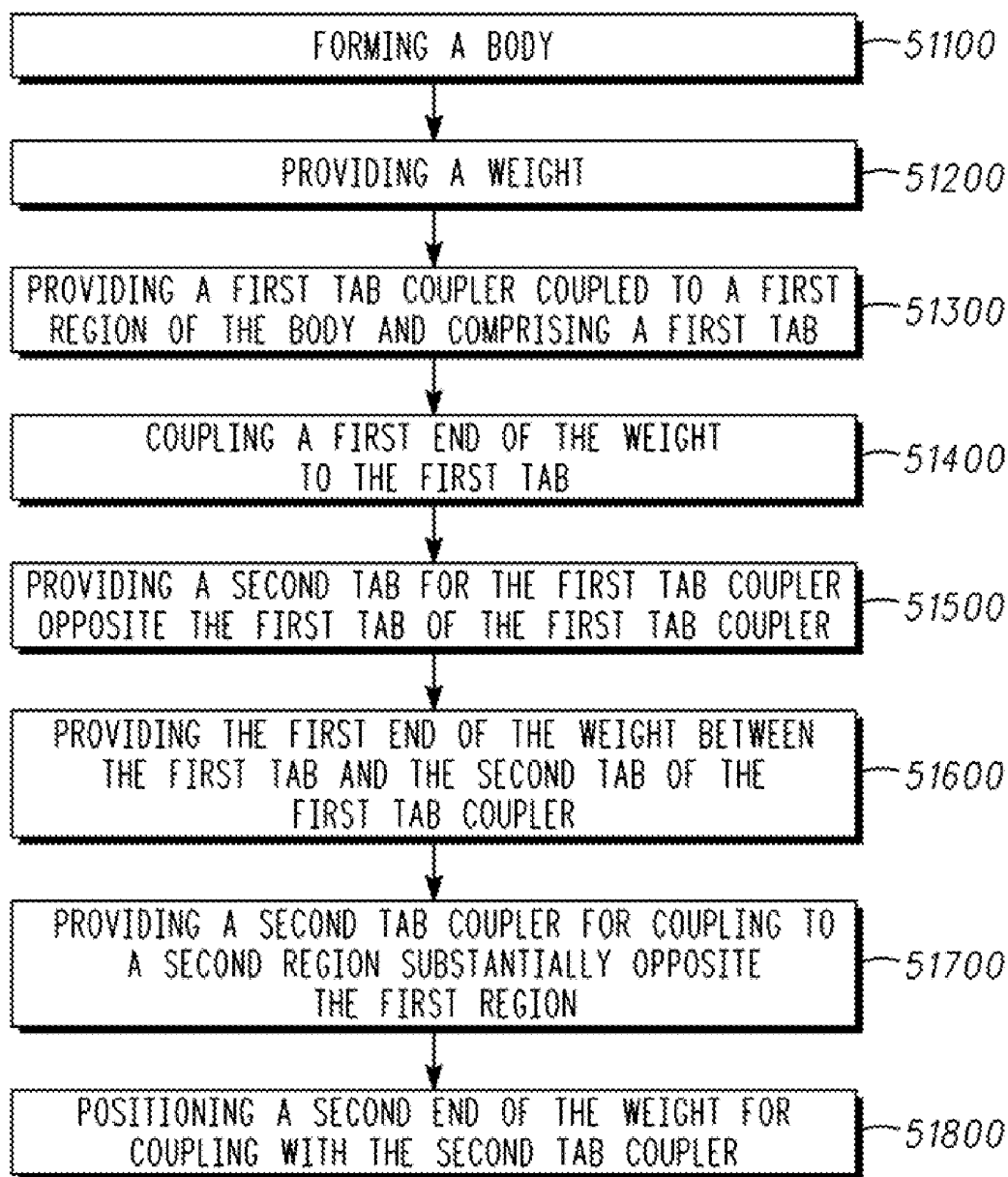

Fig. 49

50000

Fig. 50





51000

Fig. 51

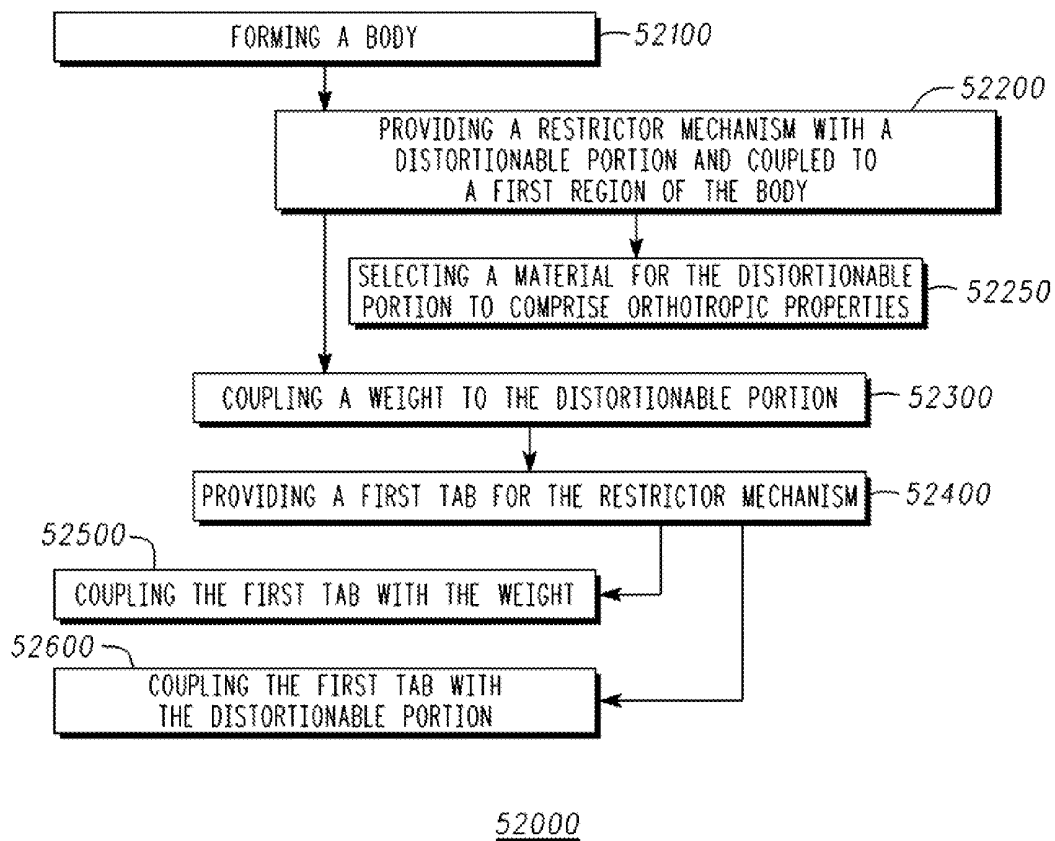

Fig. 52

GOLF CLUBS WITH VARIABLE MOMENT OF INERTIA AND METHODS OF MANUFACTURE THEREOF

TECHNICAL FIELD

[0001] This disclosure relates generally to golf equipment, and relates more particularly to golf clubs with variable moments of inertia and methods of manufacture thereof.

BACKGROUND

[0002] Some individuals who play golf may have a tendency to hit a golf ball with a hook or draw, or a slide or facie. These unintended trajectories can be the result of hitting the golf ball outside a central region of the golf club face. Hitting the golf ball outside this region can rotate the golf club head, which can cause an unintended spin on the golf ball, and this spin can exacerbate an individual's tendency to hook/draw or slide/fade the golf ball. Therefore, a need exists to minimize the club head rotation when an individual hits a golf ball outside the central region of the golf club face.

BRIEF DESCRIPTION OF THE DRAWINGS

[0003] FIG. 1 illustrates a perspective cross-sectional view of part of a golf club head.

[0004] FIG. 2 illustrates a top cross-sectional view of part of the golf club head of FIG. 1.

[0005] FIG. 3 illustrates a top cross-sectional view of part of the golf club head of FIG. 1 with a restrictor mechanism and interacting with a golf ball at a heel portion.

[0006] FIG. 4 illustrates a top cross-sectional view of part of the golf club head of FIG. 1 interacting with a golf ball at a toe portion.

[0007] FIG. 5 illustrates a top cross-sectional view of part of a golf club head comprising a different restrictor mechanism and interacting with the golf ball at the heel portion.

[0008] FIG. 6 illustrates a top cross-sectional view of part of the golf club head of FIG. 5 and interacting with the golf ball at the toe portion.

[0009] FIG. 7 illustrates a top cross-sectional view of part of a golf club head comprising another restrictor mechanism and interacting with the golf ball at a heel portion.

[0010] FIG. 8 illustrates a top cross-sectional view of part of the golf club head of FIG. 7 interacting with the golf ball at a toe portion of golf club head of FIG. 7.

[0011] FIG. 9 illustrates a top cross-sectional view of part of a golf club head comprising yet another restrictor mechanism and interacting with the golf ball at the toe portion.

[0012] FIG. 10 illustrates a top cross-sectional view of part of the golf club head of FIG. 9 interacting with the golf ball at the heel portion.

[0013] FIG. 11 illustrates a top cross-sectional view of part of a golf club head comprising a further restrictor mechanism interacting with the golf ball at the heel portion.

[0014] FIG. 12 illustrates a top cross-sectional view of part of the golf club head of FIG. 11 interacting with the golf ball at a toe portion.

[0015] FIG. 13 illustrates a top cross-sectional view of part of a golf club head comprising another different restrictor mechanism and interacting with the golf ball at the toe portion.

[0016] FIG. 14 illustrates a top cross-sectional view of part of the golf club head of FIG. 13 interacting with the golf ball at the heel portion.

[0017] FIG. 15 illustrates a perspective cross-sectional view of part, of a golf club head comprising one dual-restrictor mechanism.

[0018] FIG. 16 illustrates a top cross-sectional view of part of the golf club head of FIG. 15.

[0019] FIG. 17 illustrates a perspective cross-sectional view of part of a golf club head comprising two single-restrictor mechanisms.

[0020] FIG. 18 illustrates a perspective cross-sectional view of part of a golf club head comprising one single-restrictor mechanism and one dual-restrictor mechanism.

[0021] FIG. 19 illustrates a top cross-sectional view of part of the golf club head of FIG. 18.

[0022] FIG. 20 illustrates a perspective cross-sectional view of part of a golf club head comprising two dual-restrictor mechanisms.

[0023] FIG. 21 illustrates a top cross-sectional view of part of the golf club head of FIG. 20.

[0024] FIG. 22 illustrates a perspective cross-sectional view of part of a golf club head comprising a weight with a mass-cutout.

[0025] FIG. 23 illustrates a perspective cross-sectional view of part of a golf club head comprising four dual-restrictor mechanisms.

[0026] FIG. 24 illustrates a perspective cross-sectional view of part of a golf club head comprising five dual-restrictor mechanisms.

[0027] FIG. 25 illustrates a top cross-sectional view of part of the golf club head of FIG. 24.

[0028] FIG. 26 illustrates a perspective cross-sectional view part of a golf club head comprising two dual-restrictor mechanisms and two hinge-pin restrictor mechanisms.

[0029] FIG. 27 illustrates a top cross-sectional view of part of a golf club head with a coupler restrictor mechanism.

[0030] FIG. 28 illustrates a top cross-sectional view of part of a golf club head with a weight-edge restrictor mechanism.

[0031] FIG. 29 illustrates a perspective view of a restrictor mechanism comprising a notched restrictor.

[0032] FIG. 30 illustrates a top cross-sectional view of a portion of a golf club head comprising an adjustable restrictor mechanism.

[0033] FIG. 31 illustrates a perspective view of a restrictor cap of the restrictor mechanism of FIG. 30.

[0034] FIG. 32 illustrates a perspective view of another restrictor cap of the restrictor mechanism of FIG. 30.

[0035] FIG. 33 illustrates a perspective cross-sectional view of part of a golf club head comprising another restrictor mechanism.

[0036] FIG. 34 illustrates a perspective cross-sectional view of part of the golf club head of FIG. 33, focusing on a weight.

[0037] FIG. 35 illustrates a perspective cross-sectional view of part of the golf club head of FIG. 33, focusing on a tab set.

[0038] FIG. 36 illustrates a top cross-sectional view of part of the golf club head of FIG. 33.

[0039] FIG. 37 illustrates a top cross-sectional view of part of the golf club head of FIG. 33 interacting with the golf ball at a heel portion.

[0040] FIG. 38 illustrates a top cross-sectional view of part of the golf club head of FIG. 33 interacting with the golf ball at a toe portion.

[0041] FIG. 39 illustrates a top cross-sectional view of part of a golf club head with a different restrictor mechanism.

[0042] FIG. 40 illustrates a top cross-sectional view of part of a golf club head with an angled restrictor mechanism.

[0043] FIG. 41 illustrates a top cross-sectional view of part of a golf club head comprising a restrictor mechanism with one single-pole tab set.

[0044] FIG. 42 illustrates a top cross-sectional view of part of a golf club head comprising a restrictor mechanism with one dual-pole tab set.

[0045] FIG. 43 illustrates a top cross-sectional view of part of a golf club head comprising a restrictor mechanism with two single-pole tab sets.

[0046] FIG. 44 illustrates a top cross-sectional view of part of a golf club head comprising a restrictor mechanism with two dual-pole tab sets.

[0047] FIG. 45 illustrates a perspective cross-sectional view of part of a golf club head comprising a restrictor mechanism with a deformable base.

[0048] FIG. 46 illustrates another perspective cross-sectional view of part of the golf club head of FIG. 45, showing part of the restrictor mechanism of FIG. 45.

[0049] FIG. 47 illustrates a top cross-sectional view of part of the golf club head of FIG. 45.

[0050] FIG. 48 illustrates a top cross-sectional view of part of a golf club head with another deformable-base restrictor mechanism.

[0051] FIG. 49 illustrates a perspective exploded view of the restrictor mechanism of FIG. 48.

[0052] FIG. 50 illustrates a perspective view of part of a golf club head comprising a different deformable-base restrictor mechanism.

[0053] FIG. 51 illustrates a flowchart of a method for manufacturing a golf club head.

[0054] FIG. 52 illustrates a flowchart for another method for manufacturing a golf club head.

[0055] For simplicity and clarity of illustration, the drawing figures illustrate the general manner of construction, and descriptions and details of well-known features and techniques may be omitted to avoid unnecessarily obscuring of the drawings. Additionally, elements in the drawing figures are not necessarily drawn to scale. For example, the dimensions of some of the elements in the figures may be exaggerated relative to other elements to help improve understanding of different embodiments. The same reference numerals in different figures denote the same elements.

[0056] The terms "first," "second," "third," "fourth," and the like in the description and in the claims, if any, are used for distinguishing between similar elements and not necessarily for describing a particular sequential or chronological order. It is to be understood that the terms so used are interchangeable under appropriate circumstances such that the embodiments of the golf club attachment mechanism and related methods described herein are, for example, capable of operation in sequences other than those illustrated or otherwise described herein. Furthermore, the terms "include," and "have," and any variations thereof, are intended to cover a non-exclusive inclusion, such that a process, method, system, article, or apparatus that comprises a list of elements is not necessarily limited to those elements, but may include other elements not expressly listed or inherent to such process, method, article, or apparatus.

[0057] The terms "left," "right," "front," "back," "top," "bottom," "over," "under," and the like in the description and in the claims, if any, are used for descriptive purposes and not necessarily for describing permanent relative positions. It is

to be understood that the terms so used are interchangeable under appropriate circumstances such that the embodiments of the golf club attachment mechanism and related methods described herein are, for example, capable of operation in other orientations than those illustrated or otherwise described herein. The term "coupled," as used herein, is defined as directly or indirectly connected in an electrical, physical, mechanical, or other manner. The term "on," as used herein, is defined as on, at, or otherwise adjacent to or next to or over.

[0058] The terms "couple," "coupled," "couples," "coupling," and the like should be broadly understood and refer to connecting two or more elements or signals, electrically and/or mechanically, either directly or indirectly through intervening circuitry and/or elements. Two or more electrical elements may be electrically coupled, either direct or indirectly, but not be mechanically coupled; two or more mechanical elements may be mechanically coupled, either direct or indirectly, but not be electrically coupled; two or more electrical elements may be mechanically coupled, directly or indirectly, but not be electrically coupled. Coupling (whether only mechanical, only electrical, or both) may be for any length of time, e.g., permanent or semi-permanent or only for an instant.

[0059] The absence of the word "removably," "removable," and the like near the word "coupled," and the like does not mean that the coupling, etc. in question is or is not removable.

DESCRIPTION

[0060] In one embodiment, a golf club head comprises a body having a front section, a first restrictor mechanism comprising a first restrictor and coupled to a first portion of the body, and a weight coupled to the body and comprising a first end coupled to the first restrictor mechanism. The first restrictor comprises a first stiffness, and the first stiffness is configured to resist a deformation of the first restrictor by the first end of the weight in response to an impact at a first zone of the front section.

[0061] In a second embodiment, a golf club head comprises a body, a restrictor mechanism coupled to the body, the restrictor mechanism comprising: a first tab of one or more tabs, a weight comprising a first side adjacent to the first tab, and a deformable portion coupled to at least one of the first tab or the weight. The restrictor mechanism is configured to permit a deformation of the deformable portion, responsive to an inertia of the weight, in response to an impact at a first zone of the body, and resist the deformation of the deformable portion, via the first tab, in response to an impact at a second zone of the body.

[0062] In a third embodiment, a golf club head, comprises a body, and a restrictor mechanism coupled to a first portion or the body. The restrictor mechanism comprises a base coupled to the first portion of the body, and a weight coupled to the base. The restrictor mechanism is configured to permit a deformation of the base in response to an inertia of the weight relative to a rotation of the golf club head in a first direction, and resist the deformation of the base in response to an inertia of the weight relative to a rotation of the golf club head in a second direction. Other examples, embodiments, and related methods are further described below.

[0063] Referring now to the figures, FIG. 1 illustrates a perspective cross-sectional view of part of golf club head 1000. FIG. 2 illustrates a top cross-sectional view of golf club head 1000. Parts of golf club head 1000 are omitted from

FIGS. 1-2 for clarity. FIG. 3 illustrates a top cross-sectional view of part of golf club head 1000 with restrictor mechanism 1200 and interacting with golf ball 3100 at a heel portion of golf club head 1000. FIG. 4 illustrates a top cross-sectional view of part of golf club head 1000 interacting with golf ball 3100 at a toe portion of golf club head 1000.

[0064] Golf club head 1000 is illustrated herein as a driver head, it will be understood, however, that other embodiments of the present invention can comprise a different type of golf club head, such as a putter head, an iron head, a hybrid head, and a fairway wood head, among others. The teachings in this disclosure are not limited to any specific type of golf club or golf club head.

[0065] As illustrated in FIGS. 1-4, golf club head 1000 comprises a body 1100 having a front section 1110, a restrictor mechanism 1200, and a weight 1300. In some embodiments, front section 1110 can be referred to as a face, or can comprise a face of golf club head 1000. In the same or different embodiments, body 1100 can be referred to as a housing. In the same or a different embodiment, body 1100 can comprise at least one of a steel material, a titanium material, an aluminum material, a graphite material, and/or other suitable materials. Golf club head 1000 can form part of a golf club with a golf club shaft (not shown) coupled to a hosel 1600 and/or a bore of golf club head 1000.

[0066] Restrictor mechanism 1200 of golf club head 1000 comprises restrictor 1210, and is coupled to body portion 1120 of body 1100. Body 1100 can also be subdivided into other portions, such as body portions 1130, 1140, 1150, and/or 2160 (FIG. 2). In the same or a different embodiment, front section 1110 can be at or proximate to a front 2111 of golf club head 1000, body portion 1120 can be at or proximate to a toe 2121 of golf club head 1000, body portion 1130 can be at or proximate to a heel 2131 of golf club head 1000, body portion 1140 can be at or proximate to a top 1141 of golf club head 1000, body portion 1150 can be at or proximate to a bottom 1151 of golf club head 1000, and/or body portion 2160 can be at or proximate to a back 2161 of golf club head 1000. Some embodiments may refer to body portions 1120, 1130, 1140, 1150, and/or 1160 as sections.

[0067] Weight 1300 is coupled to body 1100 and comprises weight end 1310 coupled to restrictor mechanism 1200. In the present embodiment, weight 1300 also comprises weight end 1320. Restrictor 1210 comprises a stiffness correlated with a Young's modulus of a material from which restrictor 1210 is made. In one example, restrictor 1210 comprises at least one of a steel material, a titanium material, an aluminum material, and/or any other suitable materials. In the same or a different embodiment, weight 1300 can comprise a mass of approximately 20 to 40 grams. In the same or a different embodiment, weight 1300 can comprise approximately 10 to 20 percent of a mass of golf club head 1000. In some embodiments, weight 1300 can comprise at least one of a tungsten material, a tungsten-epoxy material, a steel material, a copper material, a titanium material, and/or a bronze material.

[0068] As shown in FIGS. 1-2, weight 1300 of golf club head 1000 further comprises post 1380. In the present embodiment, post 1380 is coupled to body portions 1140 and 1150 of body 1100. In some embodiments, post 1380 can also be referred to as a restrictor, and can comprise a stiffness which can be less than a stiffness of restrictor 1210. Weight 1300 is at least as stiff as restrictor 1210 and can be stiffer than post 1380.

[0069] Post 1380 is configured to couple weight 1300 to body 1100, and to align weight end 1310 with restrictor 1210. In turn, restrictor 1210 is positioned behind end 1310 of weight 1300 relative to front section 1110 of body 1100 in the present embodiment. In addition, face 2361 (FIG. 2) of weight 1300 is aligned substantially parallel to front section 1110 of body 1100.

[0070] As shown in FIGS. 3-4 for the present embodiment, center of gravity 3600 of weight 1300 can be proximate to front section 1110 of golf club head 1000. In the same or a different example, center of gravity 3600 of weight 1300 can be proximate to a center of gravity of golf club head 1000. In a different example, center of gravity 3600 of weight 1300 can be proximate to a geometric center of golf club head 1000. In the same or a different example, center of gravity 3600 is substantially collinear with a gravitational vector through the center of gravity of golf club head 1000.

[0071] As shown in FIG. 3, the stiffness of restrictor 1210 is configured to resist a deformation of restrictor 1210 by end 1310 of weight 1300 in response to an impact at zone 1111 of body 1100. Restrictor mechanism 1200 can thus interact with weight end 1310 by resisting deformation of restrictor 1210 due to its stiffness. In other embodiments, the stiffness can be configured to permit certain deformation of restrictor 1210 to interact with weight end 1310. In the same or a different embodiment, deformation of restrictor 1210 can be elastic but restrictor 1210 may return to its original shape after deformation. In some embodiments, a deformation of a restrictor such as restrictor 1210 can be referred to as a distortion.

[0072] In the present example of FIG. 3, face 3200 of golf club head 1000 impacts ball 3100 substantially square with respect to an intended direction of travel for golf ball 3100. The impact at zone 1111 is proximate to the heel of golf club head 1000 in this example, thus imparting a counterclockwise rotation upon golf club head 1000, as denoted by arrow 3500. In the current embodiment, and for simplicity of description and illustration, the counterclockwise rotation is about center of gravity 3600. In other embodiments, golf club head 1000 can rotate about a different point.

[0073] Continuing with the example of FIG. 3, the counterclockwise rotation of golf club head 1000 causes restrictor 1210 to also rotate counterclockwise along with body 1100 and, as a result, to interact with end 1310 of weight 1300. As restrictor 1210 is pressed against weight end 1310, restrictor 1210 resists deformation due to its stiffness. As a result, the moment of inertia of weight 1300 is transferred through restrictor 1210 onto body 1100. In some embodiments, restrictor 1210 also impedes a rotational tendency of weight 1300 relative to body 1100 when golf club head 1000 rotates counterclockwise in response to impact with golf ball 3100. Golf club head 1000 therefore exhibits a higher moment of inertia when weight 1300 interacts with restrictor 1210, decreasing the amount of corresponding rotation 3500 imparted onto golf club head 1000 upon impact with golf ball 3100.

[0074] As illustrated in FIG. 4, weight 1300 may not affect the rotation and/or the moment of inertia of golf club head 1000. In the situation presented in FIG. 4, face 3200 of golf club head 1000 impacts ball 3100 proximate to zone 1112 of front section 1110. The impact at zone 1112 is proximate to the toe of golf club head 1000 in this example, thus imparting a clockwise rotation upon golf club head 1000, as denoted by arrow 4500.

[0075] The clockwise rotation of golf club head 1000 causes restrictor 1210 (which is fixed relative to body 1100) to also rotate clockwise along with body 1100, but the lower stiffness of post 1380 causes post 1380, and thus weight 1300, to deform with respect to body 1100. Because restrictor 1210 tends to rotate away from weight end 1310, any interaction between restrictor 1210 and weight 1300 is limited and/or restricted and, as a result, the moment of inertia of weight 1300 may not be transferred through restrictor 1210 onto body 1100. Golf club head 1000 therefore exhibits a lower moment of inertia in this situation, compared to the scenario of FIG. 3. In the same or a different embodiment, restrictor 1210 is neutral with respect, to impeding a rotational tendency of weight 1300 relative to body 1100 when golf club head 1000 rotates clockwise in response to impact at zone 1112 with golf ball 3100. As a result, in the present, example of FIG. 4, the amount of rotation imparted onto golf club head 1000 upon impact with golf ball 3100 is less affected by the mass of weight 1300. Therefore, golf club head 1000 rotates more in the clockwise direction in FIG. 4 than in the counterclockwise direction in the example of FIG. 3.

[0076] FIGS. 3-4 therefore illustrate that a weight, such as weight 1300, and a restrictor mechanism, such as restrictor mechanism 1200, can be configured to selectively impart a greater or lesser moment of inertia onto a golf club head depending on a degree of deformation of a restrictor in response to impact at specific zones of the golf club head. As will, be described in detail below, other alignments and combinations of weights and restrictor mechanisms can be used to selectively control the transfer of moments of inertia onto golf club heads.

[0077] Regardless of their deformation, or lack thereof, none of the elements of the golf club heads described herein are designed to move. For example, all of weight 1300, restrictor 1210, and post 1380 of golf club head 1000 are fixed relative to body 1100. In addition, any deformation of elements of the golf club heads described herein, including any deformation of weight 1300, restrictor 1210, and/or post 1380 of golf club head 1000, can be designed to be temporary in the same way that face 3200 of golf club head 1000 temporarily deforms upon impact with golf ball 3100.

[0078] Continuing with the figures, FIG. 5 illustrates a top cross-sectional view of part of golf club head 5000 comprising restrictor mechanism 5200 and interacting with golf ball 3100 at a heel portion of golf club head 5000. FIG. 6 illustrates a top cross-sectional view of part of golf club head 5000 comprising restrictor mechanism 5200 and interacting with golf ball 3100 at a toe portion of golf club head 5000. Golf heads 1000 (FIGS. 1-4) and 5000 (FIGS. 5-6) can be similar to each other, except that they have different restrictor mechanisms.

[0079] Restrictor mechanism 5200 in FIGS. 5-6 comprises restrictor 5210, and differs from restrictor mechanism 1200 in FIGS. 1-4 in that restrictor 5210 is positioned between end 1310 of weight 1300 and front section 1110 of body 1100. Restrictor 5210 is similar to restrictor 1210 (FIGS. 1-4) and can also comprise the same stiffness. In the example of FIG. 5, face 3200 of golf club head 5000 impacts golf ball 3100 proximate to zone 1112 of front section 1110. The impact at zone 1112 is proximate to the toe of golf club head 5000 in this example, thus imparting a clockwise rotation upon golf club head 5000, as denoted by arrow 5500.

[0080] The position of restrictor 5210 in this example produces a situation analogous but opposite to the situation

described in FIG. 3, where restrictor mechanism 5200 here can reduce a rotation of golf club head 5000. The rotation is now clockwise and causes restrictor 5210 to also rotate clockwise along with body 1100 and, as a result, to interact with end 1310 of weight 1300. As restrictor 5210 is pressed against weight end 1310, restrictor 5210 resists deformation due to its stiffness. As a result the moment of inertia of weight 1300 is transferred through restrictor 5210 onto body 1100. Golf club head 5000 therefore exhibits a higher moment of inertia when weight 1300 interacts with restrictor 5210, decreasing the amount of corresponding rotation imparted onto golf club head 5000 upon impact with golf ball 3100.

[0081] As illustrated in FIG. 6, restrictor 5210 and weight 1300 need not always affect, the rotation and/or the moment of inertia of golf club head 1000. In the present example of FIG. 6, face 3200 of golf club head 1000 impacts ball 3100 proximate to the heel of golf club head 1000, thus imparting a counterclockwise rotation upon golf club head 1000, as denoted by arrow 6500.

[0082] The positioning of restrictor 5210 in this example produces a situation analogous but opposite to the situation described in FIG. 4, where restrictor mechanism 5200 may not affect the counterclockwise rotation 6500 of golf club head 1000. Restrictor 5210 also rotates counterclockwise along with body 1100, tending to rotate away from weight end 1310 such that any interaction between restrictor 1210 and weight 1300 is limited and/or restricted. As a result, the moment of inertia of weight 1300 may not be transferred through restrictor 5210 onto body 1100. Golf club head 5000 therefore exhibits a lower moment of inertia in this situation, compared to the scenario of FIG. 5. As a result, in the present example of FIG. 6, the amount of rotation 6500 imparted onto golf club head 1000 upon impact with golf ball 3100 is less affected by the mass of weight 1300. Therefore, golf club head 5000 rotates more in the counterclockwise direction in FIG. 6 than in the clockwise direction in the example of FIG. 5.

[0083] Continuing with the figures, FIG. 7 illustrates a top cross-sectional view of part of golf club head 7000, comprising restrictor mechanism 7200 and interacting with golf ball 3100 at a heel portion of golf club head 7000. FIG. 8 illustrates a top cross-sectional view of part of golf club head 7000, comprising restrictor mechanism 7200 and interacting with golf ball 3100 at a toe portion of golf club head 7000.

[0084] Golf club heads 1000 (FIGS. 1-4) and 7000 (FIGS. 7-8) can be similar to each other, except that they have different restrictor mechanisms and that center of gravity 7600 (FIG. 7) is proximate to a geometric center of golf club head 7000. This contrasts with center of gravity 3600 for golf club head 1000 (FIGS. 3-6), positioned proximate to front section 1110. Like golf club head 1000, golf club head 7000 also comprises weight 1300.

[0085] The example shown in FIGS. 7-8 illustrates restrictor 7210 positioned behind weight end 1310 of weight 1300, relative to front section 1110. FIG. 7 shows a scenario similar to the scenario described for FIG. 3 above, where an impact with golf ball 3100 at zone 1111 of front section 1110 produces a counterclockwise rotation 7500 of golf club head 7000. This counterclockwise rotation 7500 is restricted by an interaction between restrictor 7210 and weight end 1310. FIG. 8 shows a scenario similar to the scenario described for FIG. 4, where an impact with golf ball 3100 at zone 1112 of front section 1110 produces a clockwise rotation 8500 of golf

club head 7000. This clockwise rotation 7500 may be unrestricted due to a lack of interaction between restrictor 7210 and weight end 1310.

[0086] FIG. 9 illustrates a top cross-sectional view of part of golf club head 9000 comprising restrictor mechanism 9200 and interacting with golf ball 3100 at the toe portion of golf club head 7000. FIG. 10 illustrates a top cross-sectional view of part of golf club head 9000 comprising restrictor mechanism 9200 and interacting with golf ball 3100 at the heel portion of golf club head 9000. Golf club heads 7000 (FIGS. 7-8) and 9000 (FIGS. 9-10) can be similar to each other, except that they have different restrictor mechanisms.

[0087] The examples shown in FIGS. 9-10 illustrates restrictor 9210 positioned between weight end 1310 and front section 1110. FIG. 9 shows a scenario similar to the scenario described for FIG. 5 above, where an impact with ball 3100 at zone 1112 of front section 1110 produces a clockwise rotation 9500 of golf club head 7000. This clockwise rotation 9500 is restricted by interaction between restrictor 9210 and weight end 1310. FIG. 10 shows an example similar to as described for FIG. 6, where an impact with golf ball 3100 at zone 1112 of front section 1110 produces a counterclockwise rotation 10500 of golf club head 7000. This clockwise rotation 10500 may be unrestricted due to a lack of interaction between restrictor 9210 and weight end 1310.

[0088] As described for FIGS. 1-10, the moment of inertia of a golf club and/or golf club head can be varied as desired by positioning weights and restrictors with certain resistance to deformation, such as weight 1300 and restrictors 1210 (FIGS. 1-4) and 5210 (FIGS. 5-6), to restrict or permit a rotation, of the golf club head in response to impact. Because the amount of rotation of a golf club head can affect a flight trajectory of a golf ball by inducing spin upon impact, mechanisms such as those mechanisms described herein can be used to counteract specific tendencies of particular individuals who golf, such as a tendency to hook, draw, pull, push, fade, and/or slice a golf ball.

[0089] FIGS. 3-10 illustrate different effects that weight 1300 and restrictor mechanisms 1200, 5200, 7200, and 9200 can have on spin imparted upon golf ball 3100 in response to impact, in the example of FIGS. 4, 6, 8, and 10, due to lesser interaction between weight end 1310 and restrictors 1210, 5210, 7210, and 9210, respectively, the moment of inertia of weight BOO may not be transferred to body 1100 to restrict golf club head rotations 4500, 6500, 8500, and 10500, respectively. Because the rotation of golf club heads 1000, 5000, 7000 and 9000 is less restricted, or unrestricted, by weight 1300, greater spin 3120 and 3140 can be imparted upon golf ball 3100. In contrast in the examples of FIGS. 3, 5, 7, and 9, due to greater interaction between weight end 1310 and restrictors 1210, 5210, 7210, and 9210, respectively, the moment of inertia of weight BOO is transferred to body 1100 to restrict golf club head rotations 3500, 5500, 7500, and 9500, respectively. Because the rotation of golf club heads 1000 and 7000 is thus restricted, lesser spin 3110 and 3130 can be imparted upon golf ball 3100.

[0090] In some embodiments, the direction of spin imparted on golf ball 3100 can be affected by the positioning of weights and restrictors as illustrated in FIGS. 3-10. As an example, FIG. 3 illustrates golf club 1000 imparting counterclockwise spin 3110, while FIG. 7 illustrates golf club 7000 imparting clockwise spin 3130. As previously described, golf club heads 1000 and 7000 differ in that center of gravity 3600 in FIGS. 3-6 is positioned proximate to front section 1110,

while center of gravity 7600 in FIGS. 7-10 is positioned further away from front section 1110. For FIG. 7, the counterclockwise rotation of golf club head 7000 around center of gravity 7600, due to contact with the surface of golf ball 3100, generates an opposite clockwise spin 3130 on golf ball 3100. In contrast, for FIG. 3, because of the forward positioning of center of gravity 3600, a greater amount of mass is available at the rear of golf club head 1000 to pivot around center of gravity 3600, causing front section 1110 to slide across surface 3111 of golf ball 3100, thereby producing counterclockwise spin 3110 on golf ball 3100.

[0091] Although the embodiments in FIGS. 1-10 have been presented having weight 1300 aligned substantially parallel to the front section of golf club heads 1000 and 7000, other alignments can be used to achieve similar results. For example, FIG. 11 illustrates a top cross-sectional view of part of golf club head 11000 comprising restrictor mechanism 11200 and interacting with golf ball 3100 at a heel portion of golf club head 9000. FIG. 12 illustrates a top cross-sectional view of part of golf club head 11000 comprising restrictor mechanism 11200 and interacting with golf ball 3100 at a toe portion of golf club head 11000. FIG. 13 illustrates a top cross-sectional view of part of golf club head 13000, comprising restrictor mechanism 13200, and interacting with golf ball 3100 at the toe portion of golf club head 13000. FIG. 14 illustrates a top cross-sectional view of part of golf club head 13000 comprising restrictor mechanism 13200 and interacting with golf ball 3100 at the heel portion of golf club head 13000. Golf club heads 1000 (FIGS. 1-4), 11000 (FIGS. 11-12), and 13000 (FIGS. 13-14) can be similar to each other, except that they have different restrictor mechanisms.

[0092] FIGS. 11-14 illustrate embodiments where a face of weight 1300 is aligned substantially perpendicular to front section 11.10 of body 1100 of golf club head 7000. Restrictor mechanisms 11200 and 13200 are accordingly positioned proximate to front section 1110 to align with weight end 1310. In a different embodiment, restrictor mechanisms 11200 and 13200 can be positioned proximate to a rear of the golf club heads, opposite front section 1110.

[0093] Despite the different alignments, the embodiments in FIGS. 11-14 can perform in a manner similar to the embodiments in FIGS. 7-10, respectively, upon impact with golf ball 3100. For example, the situations shown in FIGS. 11 and 13 are likely to generate an interaction between weight end 1310 and restrictors 11210 and 13210, respectively, similar to as previously described for the analogous situations shown in FIGS. 7 and 9. Similarly, the situations shown in FIGS. 12 and 14 are less likely to generate an interaction between weight end 1310 and restrictors 11210 and 13210, respectively, similar to as previously described for the analogous situations shown in FIGS. 5 and 10.

[0094] Continuing with the figures, FIG. 15 illustrates a perspective cross-sectional view of part of golf club head 15000 comprising one dual-restrictor mechanism FIG. 16 illustrates a top cross-sectional view of golf club head 15000. Golf club head 15000 is similar to golf club head 1000, but comprises restrictor mechanism 15200 rather than 1200. Restrictor mechanism 15200 comprises restrictor 1210 similar to as described above for restrictor mechanism 1200 in FIGS. 1-2. However, restrictor mechanisms 15200 and 1200 (FIG. 1-2) differ in that restrictor mechanism 15200 is a dual-restrictor mechanism that further comprises restrictor 15220 located at an opposite side of weight 1300 than restrictor 1210. In addition, weight end 1310 of weight 1300 is

configured to be positioned between restrictors 1210 and 15220. In the same or a different embodiment, weight end 1310 is within body 1100.

[0095] In the present embodiment of FIGS. 15-16, restrictor 15220 comprises a stiffness, where the stiffness of restrictor 1210 is greater than the stiffness of restrictor 15220. Here, the stiffness of restrictor 15220 is configured to permit a deformation of restrictor 15220 by weight end 1310 in response to an impact at zone 1112 of body 1100 of golf club head 15000. The impact at zone 1112 could be, for example, with golf ball 3100. In the same or a different embodiment, restrictor 15220 can comprise at least one of a silicon material, a polymer material, and an epoxy material. In a different embodiment, the relative stiffnesses of restrictors 1210 and 15220 could be inverted, such that stiffness 15221 could be greater than stiffness 1211. In the same or a different embodiment, weight end 1310 can be connected to at least one of restrictors 1210 and 15220, such as by welding, bonding, soldering, and/or gluing, among other techniques.

[0096] In the example of FIGS. 15-1.6, when golf club head 15000 rotates counterclockwise upon an impact at zone 1111, restrictor 1210 tends to interact with weight end 1310. Because the stiffness of restrictor 1210 is greater than the stiffness of restrictor 15220, restrictor 1210 tends to resist deformation due to the interaction, and thus may transfer a comparatively greater moment of inertia from weight 1300 to body 1100 of golf club head 15000. Conversely, when golf club head 15000 rotates clockwise upon an impact at zone 1112, restrictor 15220 may interact with weight end 1310. Because the stiffness of restrictor 15220 is less than the stiffness of restrictor 1210 in this example, restrictor 15220 tends to deform and/or compress due to the interaction, and thus may transfer a comparatively lesser moment of inertia from weight 1300 to body 1100 of golf club head 15000.

[0097] Carrying on with the figures, FIG. 17 illustrates a perspective cross-sectional view of part of golf club head 17000 comprising two single-restrictor mechanisms. In the present embodiment, golf club head 17000 is similar to golf club head 1000 (FIGS. 1-2), but differs by having restrictor mechanism 17200. Restrictor mechanism 17200 comprises restrictor 17210 and is coupled to body portion 1130 of body 1100. In the present embodiment, body portion 1130 is located substantially opposite to body portion 1120 of body 1100, such that restrictor mechanism 17200 is located substantially opposite to restrictor mechanism 1200. Golf club head 17000 also differs from golf club head 1000 in that weight 1300 does not couple to body 1100 via post 1380. Instead, weight 1300 comprises weight end 1320 coupled to restrictor 17210. In the same embodiment, weight end 1310 can be coupled to restrictor 1210.

[0098] In one embodiment, restrictor 17210 comprises a stiffness less than the stiffness of restrictor 1210. The stiffness of restrictor 17210 is configured to permit a deformation of restrictor 17210 by weight end 1320 of weight 1300 in response to impact at front section 1110 of body 1100. In the present example, restrictor 17210 may deform whether impact occurs proximate to zones 1111 or 1.112. In addition, even though, weight 1300 is coupled to body 1100 in a different manner, the interaction between weight end 1310 and restrictor 1210 is similar to as described above for FIGS. 1-4. In a different embodiment, restrictor 1210 can be positioned similar to restrictor 15220 from FIGS. 15-16.

[0099] FIG. 18 illustrates a perspective cross-sectional view of part of golf club head 18000 comprising one single-

restrictor mechanism and one dual-restrictor mechanism. FIG. 19 illustrates a top cross-sectional view of part of golf club head 18000. In the present, embodiment of FIGS. 18-19, golf club head 18000 is similar to golf club head 15000 (FIGS. 15-16), comprising restrictor mechanism 15200, and having weight end 1310 between restrictors 1210 and 15220. Golf club head 18000 differs from golf club head 15000 by comprising restrictor mechanism 17200, as described for FIG. 17. Weight 1300 can be attached to restrictors 15220 and 17210.

[0100] In the present example, restrictor 1210 comprises a stiffness greater than the stiffness for restrictor 15220. The stiffness for restrictor 15220 is configured to permit a deformation of restrictor 15220 by weight end 1310 in response to an impact at zone 1112 of body 1100 of golf club head 18000. As a result, less inertia can be transferred from weight 1300 to golf club head 18000 when body 1100 rotates clockwise than when body 1100 rotates counterclockwise. In a different embodiment, the locations of restrictors 1210 and 15220 could be swapped, causing a corresponding change in the transfer of inertia.

[0101] FIG. 20 illustrates a perspective cross-sectional view of part of golf club head 20000 comprising two dual-restrictor mechanisms. FIG. 21 illustrates a top cross-sectional view of part, of golf club head 20000. Golf club head 20000 is similar to golf club head 18000 (FIGS. 18-19), but comprises restrictor mechanism 20200. Restrictor mechanism 20200 is similar to restrictor mechanism 17200 (FIG. 17-19), but further comprises restrictor 20220 opposite restrictor 17210. In addition, weight end 1320 is between restrictors 17210 and 20220. Weight 1300 can be attached to restrictors 15220 and 17210.

[0102] In the present example, a stiffness of restrictor 20220 is similar to the stiffness of restrictor 1210. Similarly, the stiffness of restrictor 17210 is similar to the stiffness of restrictor 15220. The stiffness of restrictor 17210 is configured to permit a deformation of restrictor 17210 by weight, end 1320 in response to impact at zone 1112 of body 1100 of golf club head 20000. In contrast, the stiffness of restrictor 20220 is configured to resist a deformation of restrictor 20220 by weight end 1320 in response to impact at zone 1111 of body 1100 of golf club head 20000. In a different embodiment, the stiffnesses of restrictors 1210, 15220, 17220, and 20220 can be altered to achieve a desired transfer of moment of inertia to golf club head 20000 from weight 1300 upon impact at different parts of front section 1110.

[0103] FIG. 22 illustrates a perspective cross-sectional view of part of golf club head 22000 comprising a weight with a mass-cutout. Golf club head 22000 is similar to golf club head 20000, but comprises instead weight 22300. Weight 22300 comprises a mass cutout 22301, in contrast with weight 1300 of FIGS. 1-21. Mass cutout 22301 can be made larger or smaller to adjust the amount of inertia that can be transferred from weight 22300 to golf club head 22000.

[0104] FIG. 23 shows a perspective cross-sectional view of part of golf club head 23000 comprising four dual-restrictor mechanisms. The four dual-restrictor mechanisms here can be similar to any of restrictor mechanisms 15200 and 20200 described above for FIGS. 18-21. In the present example of FIG. 23, golf club head 23000 is similar to golf club head 20000 (FIGS. 20-21), comprising restrictor mechanism 15200 coupled to body portion 1120, and restrictor mechanism 20200 coupled to body portion 1130. Golf club head 23000 differs by comprising restrictor mechanism 23200,

coupled to body portion 1140 between body portions 1120 and 1130, and restrictor mechanism 23400 coupled to body portion 1150 substantially opposite to body portion 1140. In the present example, golf club head 23000 comprises weight 23300, with weight end 1310 coupled to restrictor mechanism 15200, weight end 1320 substantially opposite weight end 1310 and coupled to restrictor mechanism 20200, weight end 1330 coupled to restrictor mechanism 23200, and weight end 1340 substantially opposite weight end 1330 and coupled to restrictor mechanism 23400. In some embodiments restrictor mechanisms 23200 and 23400 can be used to control a vertical spin of golf ball 3100, similar to the way restrictor mechanisms 15200 and/or 20200 can be used to control a horizontal spin of golf ball 3100 upon impact, as described above for FIGS. 20-21. In a different embodiment, golf club head can comprise a weight similar to weight 23300 but with no mass cutout, and/or one or more of the four dual-restrictor mechanisms can instead be single-restrictor mechanisms similar to restrictor mechanisms 1200 (FIG. 1-2), and 17200 (FIG. 17).

[0105] FIG. 24 illustrates a perspective cross-sectional view part of golf club head 24000 comprising five dual-restrictor mechanisms. Body 1100 of golf club head 24000 is shown in a dashed outline form in FIG. 24 for clarity. FIG. 25 illustrates a top cross-sectional view of part of golf club head 24000. Golf club head 24000 is similar to golf club head 23000 (FIG. 23), but further comprises restrictor mechanism 24200 coupled to body portion 1160. Golf club head 24000 also comprises weight 24300, similar to weight 23300 (FIG. 23), but further comprising weight end 24350. Weight end 24350 is configured to be coupled to restrictor mechanism 24200. In the present embodiment, weight ends 1310, 1320, 1330, and 1340 are located along one plane of weight 24300, and weight end 24350 is located along another (perpendicular) plane of weight 24300. In a different embodiment golf club head 24000 could comprise a weight similar to weight 24300 but without mass cutouts, and one or more of the dual-restrictor mechanisms could instead be single-restrictor mechanisms.

[0106] Continuing with the figures, FIG. 26 shows a perspective cross-sectional view of part of golf club head 26000 comprising two dual-restrictor mechanisms and two hinge pin restrictor mechanisms. Body 1100 of golf club head 26000 is not shown in FIG. 26 for clarity. Golf club head 26000 is similar to golf club head 23000 (FIG. 23) but differs by comprising restrictor mechanism 26200 coupled to weight end 1330, and restrictor mechanism 26300 coupled to weight end 1340. Restrictor mechanism 26200 comprises hinge pins straddling weight end 1330. Similarly, restrictor mechanism 26300 comprises hinge pins straddling weight end 1340. The hinge pins need not be bonded or otherwise fastened to weight 23300.

[0107] Carrying on, FIG. 27 illustrates a top cross-sectional view of part of golf club head 27000 with a coupler restrictor mechanism. In the present example, golf club head 27000 is similar to golf club head 15000 (FIGS. 15-16), but comprises restrictor mechanism 27200 with restrictor 1210. Restrictor 1210 in the present embodiment comprises restrictor coupler 27212, where the stiffness of restrictor 1210 is greater than the stiffness of restrictor coupler 27212. In addition, weight end 1310 is coupled to restrictor coupler 27212. In the same or a different example, weight end 1310 can be attached or connected to restrictor coupler 27212 via bonding, gluing, welding, soldering, or other similar techniques. The stiffness of restrictor coupler 27212 is configured to permit deforma-

tion of restrictor coupler 27212 by weight end 1310 in response to impact at least one of zones 1111-1112 of body 1100 of golf club head 27000.

[0108] In the present embodiment, restrictor mechanism 27200 further comprises restrictor 27220 opposite restrictor 1210. Weight end 1310 is between restrictor 27220 and restrictor coupler 27212. A stiffness of restrictor 27220 is greater than the stiffness of restrictor coupler 27212. Here, the stiffness of restrictor 27220 is configured to resist a deformation of restrictor 27220 by weight end 1310 in response to impact at zone 1112 of body 1100 of golf club head 27000. In a different embodiment, restrictor mechanism 27200 could comprise only restrictor 1210 with restrictor coupler 27212 while foregoing restrictor 27220. In such an embodiment, the reaction of golf club 27220 upon impact at zones 1111 and 1112 can be different from as described above for the present example of FIG. 27.

[0109] Moving forward, FIG. 28 presents a top cross-sectional view of part of golf club head 28000 with an in-line restrictor mechanism. Golf club head 28000 is similar to golf club head 1000 (FIGS. 1-2), but comprises restrictor mechanism 28200 with restrictor 28220 instead of restrictor mechanism 1200 with only restrictor 1210.

[0110] Restrictor 28220 is between body portion 1120 and weight end 1310, and is substantially adjacent to restrictor 1210. In the present embodiment, the stiffness of restrictor 1210 is greater than the stiffness of restrictor 28220. The stiffness of restrictor 28220 is configured to permit a deformation of restrictor 28220 by weight end 1310 in response to impact at zone 1112 of body 1100 of golf club head 28000. In the present example, restrictor 1210 will resist deformation while interacting with weight end 1310 in response to impact at zone 1111, thus transferring the moment of inertia of weight 1300 to body 1100 to counteract the counterclockwise rotation of golf club head 28000. In contrast, restrictor 28220 can deform while interacting with weight end 1310 in response to an impact at zone 1112, limiting the moment of inertia of weight 1300 transferred to body 1100, and thus decreasing or negating the effect of weight 1300 upon the clockwise rotation of golf club head 28000.

[0111] Continuing with the figures, FIG. 29 shows a perspective view of restrictor mechanism 29200 comprising a notched restrictor. Restrictor mechanism 29200 can be similar to restrictor mechanism 15200 of golf club head 15000 (FIGS. 15-16), but differs by comprising restrictor 29210 with notch 29211. Weight end 29310 of weight 29300 comprises protrusion 29311 coupled with notch 29211 of restrictor 29210. In the present embodiment, restrictor mechanism 29200 also comprises restrictor 29220. In the same or a different embodiment, restrictors 29210 and 29220 can comprise different stiffnesses. In some embodiments, weight end 29310 can further comprise a protrusion similar to protrusion 29311 coupled with a notch on restrictor 29220 similar to notch 29211. Notch 29211 of restrictor 29210 is configured to restrict weight 29300 from rotating along a plane substantially parallel to face 29390 when protrusion 29311 is coupled to notch 29211. In some embodiments, restrictor mechanisms similar to restrictor mechanism 29200, and corresponding protrusions similar to protrusion 29311, can be coupled to one or more portions of a golf club head, such as to portions 1120, 1130, 1140, 1150, and 1160 shown in FIGS. 24-25.

[0112] In some embodiments of the present invention, one or more restrictor mechanisms can be adjustable relative a corresponding weight end. For example, in FIGS. 15-16,

restrictor mechanism **15200** can be adjustable relative to weight end **1310**. In one embodiment, restrictor mechanism **15200** can be adjusted by substituting restrictors **1210** and/or **15220** with other restrictors having different properties. In the same or a different embodiment, restrictor mechanism **15200** could be adjusted by swapping the locations of restrictors **1210** and **15220**. In such an embodiment, restrictor **1210** is adjustable from a position on side **1311** to side **1312** of weight end **1310**. In the same of a different embodiment, restrictors **1210** and **15220** can be swapped by removing restrictor **15200** from body **1100** and reinstalling it at a 180-degree offset. In the same or a different embodiment, the adjustment can comprise removing restrictor mechanism **15200** from body **1100** and replacing with a different restrictor mechanism.

[0113] Continuing with the figures, FIG. **30** shows a top cross-sectional view of a portion of golf club head **30000** comprising an adjustable restrictor mechanism. Golf club head **30000** can be similar to any of the golf club heads described above, but comprises restrictor mechanism **30200** instead. In the same or a different embodiment, one or more restrictor mechanisms similar to restrictor mechanism **30200** could be positioned in lieu of one or more of the restrictor mechanisms described above at different body portions of corresponding body **1100**, such as at body portions **1120**, **1130**, **1140**, **1150**, and/or **1160** (FIGS. **24** and **25**).

[0114] In the present embodiment, restrictor mechanism **30200** comprises a restrictor cap with inner perimeter **30210** and restrictors **30220** along inner perimeter **30210**. Golf club head **30000** also comprises weight **30300**, which can be similar to one or more of the weights described earlier. Weight end **30310** of weight **30300** is configured to be coupled within inner perimeter **30210**, between restrictors **30220**.

[0115] In the embodiment of FIG. **30**, the positions of restrictors **30220** relative to weight end **30310** are adjustable when the restrictor cap of restrictor mechanism **30220** is rotated relative to weight end **30310**. In one example, restrictors **30220** can comprise restrictors comprising different stiffnesses. A pair of restrictors can be initially coupled to sides **30311-30312**, respectively, of weight end **30310**. After adjustment of restrictor mechanism **30220**, a different pair of restrictors can be coupled to sides **30311-30312**, respectively, of weight end **30310**. After further adjustment of restrictor mechanism **30220**, another pair of restrictors can be coupled to sides **30311-30312**, respectively, of weight end **30310**. Restrictor mechanism **30200** can thus allow for rearrangement of different stiffnesses to which weight end **30310** can be subjected to upon impact at certain zones of body **1100**, including zones like zones **1111** and/or **1112** (FIGS. **1-2**).

[0116] Continuing with the figures, FIG. **31** shows a perspective view of restrictor cap **31200** of restrictor mechanism **30200**. FIG. **32** shows a perspective view of restrictor cap **32200** of restrictor mechanism **30200**. In some embodiments, restrictor caps **31200** and **32200** can be removable and/or interchangeable for restrictor mechanism **30200**.

[0117] Restrictor cap **31200** comprises restrictors **31210**, **31220**, **31230**, **31240**, **31250**, and **31260**, which can be similar to the restrictors from the description of FIG. **30**, but comprising inversely proportional stiffnesses. In the present example, a stiffness of restrictor **31210** is greater than a stiffness of restrictor **31230**, and the stiffness of restrictor **13230** is greater than a stiffness of restrictor **13250**. Similarly, a stiffness of restrictor **13220** is more flexible than a stiffness of restrictor **31240**, and the stiffness of restrictor **31240** is more

flexible than a stiffness of restrictor **31260**. Therefore, the stiffness of restrictor **31210** is inversely proportional to the stiffness of restrictor **31220** because restrictor **31210** is stiffest while restrictor **31220** is most flexible amongst restrictors **31210**, **31220**, **31230**, **31240**, **31250**, and **31260**. Similarly, the stiffness of restrictor **31230** is inversely proportional to the stiffness of restrictor **31240** because restrictor **31230** is the second stiffest while restrictor **31240** is the second most flexible amongst restrictors **31210**, **31220**, **31230**, **31240**, **31250**, and **31260**. Finally, the stiffness of restrictor **31250** is inversely proportional to the stiffness of restrictor **31260** because restrictor **31250** is the third stiffest while restrictor **31260** is the third most flexible amongst restrictors **31210**, **31220**, **31230**, **31240**, **31250**, and **31260**.

[0118] Other embodiments can comprise a higher or lower number of restrictors similarly paired along inner perimeter **30210**. As shown in FIG. **31**, restrictors **31210** and **31220**, **31230** and **31240**, and **31250** and **31260** are positioned opposite each other along inner perimeter **30210** of restrictor cap **31200** based on their inversely proportional stiffnesses.

[0119] Restrictor cap **32200** comprises restrictors **32210**, **32220**, **32230**, **32240**, **32250**, and **32260**, which also can be similar to the restrictors from the description of FIG. **30**, but comprising increasing stiffnesses. In the present example, a stiffness of restrictor **32210** is greater than a stiffness of restrictor **32220**, which is greater than a stiffness of restrictor **32230**, which is greater than a stiffness of restrictor **32240**, which is greater than a stiffness of restrictor **32250**, which is greater than a stiffness of restrictor **32260**. As shown in FIG. **32**, restrictors **32210**, **32220**, **32230**, **32240**, **32250**, and **32260** are positioned alongside each other along inner perimeter **30210** of restrictor cap **32200** based on their increasing stiffnesses.

[0120] Moving on with the figures, FIG. **33** illustrates a perspective cross-sectional view of part of golf club head **33000**, comprising restrictor mechanism **33200**. FIG. **34** shows a perspective cross-sectional view of part of golf club head **33000**, focusing on weight **33230** of restrictor mechanism **33200**. FIG. **35** shows a perspective cross-sectional view of part of golf club head **33000**, focusing on tab set **33220** of restrictor mechanism **33200**. FIG. **36** illustrates a top cross-sectional view of part, of golf club head **33000**. FIG. **37** illustrates a top cross-sectional view of part of golf club head **33000** interacting with, ball **3100** at zone **1111**. FIG. **38** illustrates a top cross-sectional view of part of golf club head **33000** interacting with ball **3100** at zone **1112**.

[0121] Golf club head **33000** is similar to golf club head **1000**, where restrictor mechanism **33200** can affect a rotation of golf club head **33000** via similar variable moment of inertia principles as described above for restrictor mechanism **1200** and weight **1300**, respectively, of golf club head **1000** (FIGS. **1-4**).

[0122] The embodiment of FIGS. **33-38** shows restrictor mechanism **33200** coupled to body **1100**, with weight **33230** proximate to contiguous tabs **33221** and **33222** of lab set **33220**. In the same or a different embodiment, body **1100** of golf club head **33000** can comprise face **36102** (FIG. **36**) and housing **33101**, where tab set **33220** and weight **33230** are coupled to a sole of housing **33101**. Weight **33230** comprises side **33231** and **33232** adjacent to tabs **33221** and **33222**, respectively. In a different embodiment, restrictor mechanism **33200** can comprise a single tab, adjacent to only one side of weight **33230**. In another embodiment, restrictor mechanism **33200** can comprise more than two contiguous or non-con-

tiguous tabs, adjacent to a corresponding number of sides of weight **33230**. The present example of FIGS. 33-3S shows tab **33221** substantially parallel to front portion **1110** of body **1100**, where tab **33222** is lateral, and substantially perpendicular to tab **33221** to form an "L" shape corresponding to an outer surface of weight **33230**. Other geometric configurations for restrictor mechanism **33200**, however, are possible in other embodiments.

[0123] In the present example, restrictor mechanism **33200** couples to body **1100** at body portion **1150**, proximate to a sole of golf club head **33000**. In addition, a center of gravity of golf club head **33000** is proximate to restrictor mechanism **33200**. In other embodiments restrictor mechanism **33200**, and/or other similar restrictor mechanisms, can couple to one or more of body portions **1120**, **1130**, **1140**, and/or **1160**. In the same or a different embodiment, the center of gravity of golf club head **33000** can shift according to the location of restrictor mechanism **33200**. In some embodiments, restrictor mechanism **33200** can be adjustable, for example, by being repositionable, removable and/or interchangeable with a different restrictor mechanism.

[0124] In the present example, restrictor mechanism **33200** comprises deformable portion **33240** coupled to weight **33230**. FIG. 34 shows deformable portion **33240** as a pedestal that couples weight **33230** to body **1100** proximate to tab set **33220**, where the respective stiffnesses of weight **33230** and tab set **33220** can be greater than the stiffness of deformable portion **33240**. In a the same or a different embodiment, restrictor mechanism **33200** can comprise a different deformable portion that could be coupled to, or be part of, one or more tabs of tab set **33220** or of a different tab set.

[0125] In some embodiments, deformable portion **33240** can comprise at least one of a silicon material, a polymer material, and an epoxy material. In the same or a different embodiment, weight **33230** can comprise a mass of approximately 20 to 40 grams. In the same or a different embodiment, weight **33230** can comprise approximately 10 to 20 percent of a mass of golf club head **33000**.

[0126] As shown in FIG. 37, restrictor mechanism **33200** can be configured to permit deformation of deformable portion **33240**, responsive to inertia of weight **33230**, upon impact, at zone **1111** of body **1100**. Tab set **33220** tends to rotate away from weight **33230** in the direction of arrow **37001** and along with body **1100** as golf club head **33000** rotates counterclockwise in response to impact at zone **1111**. As a result of the initial stationary inertia of weight **33230**, deformable portion **33240** tends to deform in the direction of arrow **37002** such that tab set **33220** tends to not interact with weight **33230** in the present situation. Little or no inertia is thus transferred from weight **3330** via tab set **33220** to body **1100** to counteract the counterclockwise rotation of head **33000**.

[0127] In the same or a different embodiment, as shown in FIG. 38, restrictor mechanism **33200** can be configured to resist deformation of deformable portion **33240**, via one or more of tabs **33221-33222**, upon impact at zone **1112** of body **1100**. In the present embodiment, both tabs **33221-33222** are configured to resist deformation of deformable portion **33240** upon impact at zone **1112** of body **1100**. Tab set **33220** tends to rotate in the direction of arrow **38001** towards weight **33230** and along with body **1100** as golf club head **33000** rotates clockwise in response to impact at zone **1112**. Because of the initial stationary inertia of weight **33230**, deformable portion **33240** tends to deform in the direction of arrow **38002**

such that tab set **33220** tends to interact with weight **33230** in the present situation. As weight **33230** is pressed against tab set **33220**, further deformation of deformable portion **33240** is resisted. As a result, inertia can be transferred from weight **3330** via tab set **33220** to body **1100** to counteract the clockwise rotation of head **33000**.

[0128] Continuing with the figures, FIG. 39 shows a top cross-sectional view of part of golf club head **39000**, comprising restrictor mechanism **39200**. Golf club head **39000** is similar to golf club head **33000** (FIGS. 33-38), but differs in that restrictor mechanism **39200** comprises tab set **39220** in addition to tab set **33220**. Tab set **39220** can couple to body **1100** in a manner similar to the manner described above for tab set **33220** (FIG. 33-35). In addition, tab set **39220** can couple to an outer surface of weight **33230** similar to as described above for tabs set **33220**, where tabs **39221-39222** respectively couple to sides **39331-39332** of weight **33230**.

[0129] In the present embodiment, tab set **33220** comprises a stiffness greater than a stiffness of tab set **39220**. The stiffness of tab set **39220** can make tab set **39220** deformable, similar to the stiffness of deformable portion **33240** (FIGS. 33-38). In the same or a different embodiment, a deformable portion of restrictor mechanism **33200** (FIG. 33) can comprise or be part of restrictor mechanism **39200**. In a different embodiment, the stiffnesses of tab sets **33220** and **39220** can be inverted. In a further embodiment, tab set **39220** can have the same stiffness as tab set **33220**. In this further embodiment, the spacing between weight **33230** and tab set **39220** can be different than the spacing between weight **33230** and tab set **33220**.

[0130] FIG. 40 illustrates a top cross-sectional view of part of golf club head **40000**, comprising angled restrictor mechanism **40200**. Golf club head **40000** is similar to golf club head **33000** (FIGS. 33-38), differing in that a tab of restrictor mechanism **40200** is not substantially parallel to front section **1110**. Instead, at least a part of restrictor mechanism **40200** forms a non-perpendicular angle **40001** with front portion **1110**.

[0131] In the present example, angle **40001** can be of approximately between 20 to 30 degrees. In the same or different embodiments angle **40001** can be configured to place one or more tabs of tab set **33220** at a desired angle **40002** relative to a predicted impact, vector **40003**. For example, impact vector **40003** can be determined based on a tendency to hit a golf ball with an open or closed golf club face. In the same or a different embodiment, angle **40001** of restrictor mechanism **40200** corresponds to angle **40004** of impact with body **1100**. In the same or a different, embodiment, angle **40001** can position a tab of tab set **33220** of restrictor mechanism **40200** relatively square with a point and direction of impact with ball **3100**, even if front section **1110** is not square with the point and direction of impact.

[0132] Continuing with the figures, FIG. 41 shows a top cross-sectional view of part, of golf club head **41000** comprising restrictor mechanism **41200** with one single-pole tab set. FIG. 42 shows a top cross-sectional view of part of golf club head **42000** comprising restrictor mechanism **42200** with one dual-pole tab set. FIG. 43 shows a top cross-sectional view of part of golf club head **43000** comprising restrictor mechanism **43200** with two single-pole tab sets. FIG. 44 shows a top cross-sectional view of part of golf club head **44000** comprising restrictor mechanism **44200** with two dual-pole tab sets. Golf club heads **41000**, **42000**, **43000**, and

44000 are similar to golf club head **33000** (FIG. 33), but have different restrictor mechanisms.

[0133] In the embodiments of FIGS. 41-44, corresponding tab sets of restrictor mechanisms **41200**, **42200**, **43200**, and **44200** comprise non-contiguous tabs or posts. More specifically, in FIG. 41, restrictor mechanism **41200** of golf club head **41000** comprises tab set **41220** with non-contiguous tabs or single posts **41221** and **41222** respectively coupled to sides **33231** and **33232** of weight **33230**. In FIG. 42, restrictor mechanism **42200** of golf club head **42000** comprises tab set **42220** with non-contiguous tabs or dual posts **42221** and **42222** respectively coupled to sides **33231** and **33232** of weight **33230**. The embodiment of FIG. 43 is similar to that of FIG. 41, but also comprises tab set **43250** with non-contiguous tabs or single posts **43251** and **43252** respectively coupled to sides **39331** and **39332** of weight **33230**. The embodiment of FIG. 44 is similar to that of FIG. 42, but also comprises tab set **44250** with non-contiguous tabs or dual posts **44251** and **44252** respectively coupled to sides **39331** and **39332** of weight **33230**.

[0134] The different posts described above for FIGS. 41-44 can have different respective stiffnesses to accordingly affect interaction with weight **33230** upon impact at different zones of body **1100**. For example, for FIG. 44, a stiffness of tab set **44220** can be greater than a stiffness of tab set **44250**, similar to as described above for tab sets **33220** and **39220** (FIG. 39). In the same or a different example, the spacing between weight **33230** and the different tab sets can be varied depending on the desired effect on the club head. For example, for FIG. 44, tab set **44250** can be positioned to permit a spacing between dual posts **44252** and side **39331**, and/or between dual posts **44251** and side **39332**.

[0135] Moving along, FIG. 45 illustrates a perspective cross-sectional view of part of golf club head **45000** comprising restrictor mechanism **45200** with a deformable base. FIG. 46 shows another perspective cross-sectional view of part of golf club head **45000**, showing part of restrictor mechanism **45200**. FIG. 47 shows a top cross-sectional view of part of golf club head **45000**. Golf club head **45000** is similar to golf club head **1000** (FIG. 1), where restrictor mechanism **45200** can affect a rotation of golf club head **45000** via similar variable moment of inertia principles of as described above for restrictor mechanism **1200** and weight **1300**, respectively, of golf club head **1000** (FIGS. 1-4).

[0136] In the embodiment of FIGS. 45-47, restrictor mechanism **45200** is coupled to portion **1150** of body **1100** and comprises both base **45220** and weight **45230**. Base **45220** comprises opposite sides **46228** (FIG. 26) and **46229** (FIG. 46). Side **46229** is coupled to portion **1150** of body **1100** proximate to base end **45222**. Side **46228** is coupled to weight **45230** proximate to base end **45221**. In the present embodiment, base **45220** is ring-shaped, although other geometric configurations are possible. In the same or a different embodiment, the positioning or location of restrictor mechanism **45200** relative to body **1100** can be varied similar to as described above for restrictor mechanism **33200** (FIGS. 33-38) and the restrictor mechanisms in FIG. 24. Restrictor mechanism **45200** is configured to permit deformation of base **45220** in response to rotational inertia of weight **45230** relative to the rotation of golf club head **45000** in a first direction (i.e., a counterclockwise direction **47510** (FIG. 47)). In the same or a different embodiment, restrictor mechanism **45200** is configured to resist deformation, of base **45220** in response to rotational inertia of weight **45230** relative to

rotation of golf club head **45000** in a second direction (i.e., a clockwise direction **47530** (FIG. 47)).

[0137] In some embodiments, weight **45230** can comprise a mass of approximately 20 to 40 grams. In the same or a different embodiment, weight **45230** can comprise approximately 1.0 to 20 percent of a mass of golf club head **45000**. In the same or a different embodiment, base **45220** can comprise a graphite material, among others.

[0138] In one example, base **45220** can deform by twisting to compress, and can resist deformation by resisting twisting to elongate and creating tension. In a different example, base **45220** can deform by twisting to elongate in response to tension, and can resist deformation by resisting twisting to compress.

[0139] In the example shown in FIG. 47, because weight **45230** is coupled proximate to base end **45221**, while base end **45222** is fixed to section **1150** of body **1100**, the inertia of weight **45230** may have a compressive effect on base **45220** when golf club head **45000** rotates counterclockwise along direction **47510**. In addition, the inertia of weight **45230** can tend to have a tensile effect on base **45220** when golf club head **45000** rotates clockwise.

[0140] Correspondingly, in the present embodiment, base **45220** is configured to deform due to the inertia of weight **45230** compressing base **45220** when golf club head **45000** rotates in direction **47510** in response to impact at zone **1111**. Base **45220** is also configured to resist tensile deformation induced by the rotational inertia of weight **45230** when golf club head **45000** rotates in direction **47530** in response to impact at zone **1112**.

[0141] Because of the compressive deformation of base **45220** in this embodiment, less inertia from weight **45230** is transferred to body **1100** via base **45220** to counteract the counterclockwise rotation of golf club head **45000** in response to impact at zone **1111**. In contrast, because of the resistance to tensile deformation of base **45220**, more inertia from weight **45230** can be transferred to body **1100** via base **45220** to counteract the clockwise rotation of golf club head **45000** in response to impact at zone **1112**. Other configurations for restrictor mechanism **45200**, and corresponding effects, are possible in other embodiments.

[0142] In the present embodiment, base **45220** comprises an orthotropic material configured to deform in one direction and to resist deformation in another direction. In the same or a different embodiment, base **45220** can comprise one or more fiber strands **46223** extended from base end **45221** to base end **45222**. In the same or a different embodiment, the fiber strands can be configured to permit compression of base **45220**, and to resist tension of base **45220**.

[0143] Continuing with the figures, FIG. 48 illustrates a top cross-sectional view of part of golf club head **48000** comprising restrictor mechanism **48200**. FIG. 49 illustrates a perspective exploded view of restrictor mechanism **48200**. Golf club head **48000** is similar to golf club head **45000** (FIGS. 45-47), but comprises restrictor mechanism **48200** with base **48220** and base detent **48250** instead. Base detent **48250** is coupled to body portion **1150** proximate to base end **45221**. Base **48220** couples to body portion **1150** and to weight **45230** similar to the coupling described above for base **45220** (FIGS. 45-47).

[0144] In the present embodiment, base **48220** can comprise an isotropic material, capable of compressing and/or decompressing in different directions. For example, similar to the compression described above for base **45220** in FIG. 47,

base **48220** can tend to compress in response to inertial effects from weight **45230** upon impact at zone **1111**, and/or upon counterclockwise rotation of golf club head **48000** along direction **47510**.

[0145] In contrast, being isotropic, base **48220** would normally tend to deform by elongating in response to inertial effects from weight **45230** upon impact at zone **1112** and/or upon clockwise rotation of golf club head **48000** along direction **47530**. However, in the present example, base detent **48250** can restrict such elongation when base end **45221** is pressed against base detent **48250**. In the present example, base detent **48250** is thus configured to restrict deformation of base **48220** in response to impact at portion **1112** of body **1100**.

[0146] Carrying on, FIG. **50** illustrates a perspective view of part of golf club head **50000** comprising restrictor mechanism **50200** with a different deformable base. Restrictor mechanism **50200** is similar to restrictor mechanisms **45200** and **48200** of FIGS. **45-49**, differing by comprising weight **50230** and base **50220** instead. Base **50220** can be similar to bases **45220** and **48220** (FIGS. **45-49**), but comprises side surface **50225**. Weight **50230** is configured to couple to side surface **50225** of base **50220**. In the present embodiment, weight **50230** surrounds the entire perimeter of base **50220** along side surface **50225**.

[0147] In some embodiments, one or more of restrictor mechanisms **45220**, **48220**, and/or **50220** (FIGS. **45-50**) can be adjustable such as, for example, by being removable, interchangeable, and/or repositionable.

[0148] Moving along, FIG. **51** illustrates a flowchart of a method **51000** for manufacturing a golf club head, in some embodiments, the golf club head of method **51000** can be one of golf club heads **1000** (FIGS. **1-4**), **5000** (FIGS. **5-6**), **7000** (FIGS. **7-8**), **9000** (FIGS. **9-10**), **1100** (FIGS. **11-12**), **13000** (FIGS. **13-14**), **15000** (FIGS. **15-16**), **17000** (FIG. **17**), **18000** (FIGS. **18-19**), **20000** (FIGS. **20-21**), **22000** (FIG. **22**), **23000** (FIG. **23**), **24000** (FIGS. **24-25**), **26000** (FIG. **26**), **27000** (FIG. **27**), **28000** (FIG. **28**), and **30000** (FIG. **30**) as described above. In some embodiments, the golf club head of method **51000** can be a driver-type head, a putter-type head, a wedge-type head, an iron-type head, a hybrid-type head, and/or a fairway wood-type head, among others.

[0149] Block **51100** of method **51000** comprises forming a body of the golf club head. In some embodiments, the body can be body **1100** as described above throughout FIGS. **1-30**. In the same or a different embodiment, the body can be referred to as a housing or a shell. In the same or a different embodiment, the body can comprise a hosel and/or a bore capable of coupling with a golf club shaft.

[0150] Block **51200** of method **51000** comprises providing a weight. In some embodiments, the weight can be similar to weights **1300** (FIGS. **1-21**, **27-28**), **22300** (FIG. **22**), **23300** (FIGS. **23** and **26**), **24300** (FIGS. **24-25**), and **30300** (FIG. **30**), among others.

[0151] Block **51300** of method **51000** comprises providing a first tab coupler coupled to a first region of the body and comprising a first tab. In some embodiments, the first tab coupler can be one of restrictor mechanisms **1200** (FIGS. **1-4**, **17**), **5200** (FIGS. **5-6**), **7200** (FIGS. **7-8**), **9200** (FIGS. **9-10**), **11200** (FIGS. **11-12**), **13200** (FIGS. **13-14**), **15200** (FIGS. **15-16**, **18-21**, **23-25**), **17200** (FIGS. **17-19**), **20200** (FIGS. **20-21**, **23-25**), **23200** (FIGS. **23-25**), **23400** (FIGS. **23-25**), **24200** (FIGS. **24-25**), **27200** (FIG. **27**), **28200** (FIG. **28**), **29200** (FIG. **29**), **30200** (FIG. **30**), **31200** (FIG. **31**), and/or

32200 (FIG. **32**), among others. In the same or a different embodiment, the first tab can be, for example, similar to restrictors **1210** (FIGS. **1-4**, **15-21**, **23-25**, **27-28**), **29210** (FIG. **29**), and **30210** (FIG. **30**). The first portion of the body can be, for example, one of body portions **1120**, **1130**, **1140**, **1150**, and **1160** (FIGS. **1-2**).

[0152] Block **51400** of method **51000** comprises coupling a first end of the weight to the first tab. In some examples, the first end of the weight can be one of weight ends **1310** (FIGS. **1-21**, **24-25**, **27-28**), **1320** (FIGS. **1-2**, **15-21**, **23-25**), **1330** (FIGS. **23-26**), **1340** (FIGS. **23-26**), **24350** (FIGS. **24-25**), **29310** (FIG. **29**), and/or **30310** (FIG. **30**), among others. The first end of the weight can be coupled to the first tab by aligning the first end of the weight to be positioned adjacent to the first tab. In the same or different embodiment, the first end of the weight can also be coupled to the first tab by being attached to the first tab, as explained in more detail below.

[0153] In some examples, method **51000** can comprise block **51500**. Block **51500** comprises providing a second tab for the first tab coupler opposite the first tab of the first tab coupler. In the same or a different embodiment, the second tab can be similar to restrictors **15220** (FIG. **15-16**, **18-25**), **27220** (FIG. **27**), **28220** (FIG. **28**), **29220** (FIG. **29**), and/or **30220** (FIG. **30**). In one embodiment, blocks **51300** and **51500** are performed simultaneously with each, other or in reverse order.

[0154] In examples where method **51000** comprises block **51500**, method **51000** can comprise block **51600**. Block **51600** comprises positioning the first end of the weight between the first tab and the second tab of the first tab coupler. In the same or a different example, the second tab can be configured to permit a greater distortion than the first tab. In one embodiment, blocks **51400** and **51600** can be performed simultaneously with each other.

[0155] For method **51000**, the weight is configured to restrict or have a minimal effect upon a rotational tendency of the body of the golf club head upon an interaction between the first end of the weight and the first tab, which is responsive to an impact at a first portion of the body of the golf club head. In some embodiments, the first portion of the body can be a face or a front portion, such as for example zones **1111** and/or **1112** (FIGS. **1-21**, **27-28**). In the same or a different embodiment, the rotational tendency of the body can be restricted via principles similar to as described, for example, for FIGS. **3-14**. In one embodiment, the rotational tendency can be clockwise. In a different embodiment, the rotational tendency can be counterclockwise.

[0156] In some examples of method **51000**, the first end of the weight can be further connected to the first, and/or second tab by bonding, welding, brazing, and/or gluing. In other embodiments, the first end of the weight can be coupled with the first and/or second tab by being aligned with the first tab coupler, even if there is no permanent connection to the first and/or second tab. In the same or different examples, the first tab coupler can be adapted to be adjustable relative to the first end of the weight such as, for example, by being removable, repositionable, replaceable, and/or interchangeable.

[0157] In some examples, method **51000** further comprises block **51700**. Block **51700** comprises providing a second tab coupler for coupling to a second region of the body substantially opposite the first region of the body. The second tab coupler can be similar to the first tab coupler in block **51300**.

[0158] In examples comprising block **51700**, a block **51800** of method **51000** can comprise positioning a second end of

the weight for coupling with the second tab coupler. Block **51800** can be carried out in a manner similar to the manner described for blocks **51300**, **51400**, and/or **51600** above for the first end of the weight with the first tab coupler. In the same or a different example, further tab couplers can be added to the body to couple with other ends of the weight.

[0159] In one embodiment, one or more of blocks **51100**, **51200**, **51300**, **51400**, **51500**, **51600**, **51700**, and/or **51800** of method **51000** can be subparts of a single step. In the same or a different embodiment, the sequence of blocks **51100**, **51200**, **51300**, **51400**, **51500**, **51600**, **51700**, and/or **51800** of method **51000** can be changed.

[0160] Progressing ahead. FIG. **52** illustrates a flowchart for a method **52000** for manufacturing a golf club head. In some embodiments, the golf club head of method **51000** can be one of golf club heads **33000** (FIGS. **33-38**), **39000** (FIG. **39**), **40000** (FIG. **40**), **41000** (FIG. **41**), **42000** (FIG. **42**), **43000** (FIG. **43**), **44000** (FIG. **44**), **45000** (FIGS. **45-47**), **48000** (FIGS. **48-49**), and/or **50000** (FIG. **50**). In some embodiments, the golf club head of method **52000** can be a driver head, a putter head, an iron head, a hybrid head, and/or a fairway wood head, among others.

[0161] Block **52100** of method **52000** comprises forming a body of the golf club head. In some embodiments, the body can be body **1100** as described above throughout FIGS. **33-50**. In the same or a different embodiment, the body can be referred to as a housing or a shell. In the same or a different embodiment, the body can comprise a hosel and/or a bore capable of coupling with a golf club shaft.

[0162] Block **52200** of method **52000** comprises providing a restrictor mechanism with a distortable portion and coupled to a first region of the body, in some embodiments, the distortable portion can be similar to deformable portion **33240** (FIGS. **33-34**), base **45220** (FIGS. **45-47**), base **48220** (FIGS. **48-49**), and base **50220** (FIG. **50**).

[0163] In some examples, block **52200** of method **52000** can comprise sub-block **52500**. Sub-block **52500** comprises selecting the distortable portion to comprise one or more orthotropic properties. In some examples, the distortable portion comprising orthotropic properties can be similar to base **45220** (FIGS. **45-47**).

[0164] Block **52300** of method **52000** comprises coupling a weight to the distortable portion. In some embodiments, the weight can be similar to weights **33230** (FIGS. **33-34**, **36-44**), **45230** (FIGS. **45**, **47-49**), and/or **50230** (FIG. **50**). In some embodiments, the weight can be coupled to the distortable portion in a manner similar to the manner described above in FIGS. **33-44** for weight **33230** and the pedestal of deformable portion **33240** (FIGS. **33-34**). In a different embodiment, the weight can be coupled to the distortable portion similar to the manner described above in FIGS. **45-50** for weights **45230** and **50230** with bases **45220**, **48220** and **50220**.

[0165] In some examples, method **52000** can comprise block **52400**. Block **52400** comprises providing a first tab for the restrictor mechanism. In some embodiments, the first tab can be similar to the tabs described in FIGS. **33-44** for tab sets **33220**, **39220**, **4.1220**, **42220**, **43220**, **43250**, **44220**, and/or **44250**, respectively. In a different embodiment, the first tab can be similar to the detent described in FIGS. **48-49** for base detent **48250**.

[0166] In examples of method **52000** comprising block **52400**, method **52000** can further comprise block **52500**. Block **52500** comprises coupling the first tab with the weight. In some examples, the first tab can be coupled to the weight

similar to the coupling described in FIGS. **33-44** for tab sets **33220**, **39220**, **41220**, **42220**, **43220**, **43250**, **44220**, and/or **44250**, respectively, with weight **33230**.

[0167] In examples of method **52000** comprising block **52400**, method **52000** can further comprise block **52600**. Block **52600** comprises coupling the first tab with the distortable portion. Blocks **52500-52600** are not dependent upon each other, and either block can be carried out without carrying out the other. In some examples of block **52600**, the first tab can be coupled with the distortable portion similar to the coupling described in FIGS. **48-49** for base detent **48250** and weight **45230**.

[0168] In one embodiment, one or more of blocks **52100**, **52200**, **52250**, **52300**, **52400**, **52500**, and **52600** of method **52000** can be subparts of a single step. In the same or a different embodiment, the sequence of blocks **52100**, **52200**, **52250**, **52300**, **52400**, **52500**, and **52600** of method **52000** can be changed. In the same or a different embodiment, method **52000** can comprise further or different steps, such as a repetition of one or more of steps **52200**, **52250**, **52300**, **52400**, **52500**, and/or **52600** for a second point, of the body.

[0169] Although the golf club with variable moment of inertia and methods of manufacture thereof have been described with reference to specific embodiments, various changes may be made without departing from the spirit or scope of the golf club attachment mechanism and related methods. Various examples of such changes have been given in the foregoing description. As another example, the restrictor mechanisms illustrated herein are shown to be enclosed within a driver head, but a restrictor mechanism can be exposed or enclosed if incorporated into an iron head. Accordingly, the disclosure of embodiments of the golf club with variable moment of inertia and methods of manufacture thereof is intended to be illustrative of the scope of the application and is not intended to be limiting. It is intended that the scope of this application shall be limited only to the extent required by the appended claims. For example, it will be readily apparent that the golf club with variable moment of inertia and methods of manufacture thereof discussed herein may be implemented in a variety of embodiments, and that the foregoing discussion of certain of these embodiments does not necessarily represent a complete description of all possible embodiments. As a specific example, although FIGS. **24-25** show golf club head **24000** to comprise five restrictor mechanisms, other embodiments could be practiced comprising more than five restrictor mechanisms, and/or with restrictor mechanisms aligned and/or positioned differently, while still following the same concepts. Therefore, the detailed description of the drawings, and the drawings themselves, disclose at least one preferred embodiment of the golf club with variable moment of inertia and methods of manufacture thereof, and may disclose alternative embodiments of the golf club with variable moment of inertia and methods of manufacture thereof.

[0170] All elements claimed in any particular claim are essential to the golf club with variable moment of inertia and methods of manufacture thereof claimed in that particular claim. Consequently, replacement of one or more claimed elements constitutes reconstruction and not repair. Additionally, benefits, other advantages, and solutions to problems have been described with regard to specific embodiments. The benefits, advantages, solutions to problems, and any element or elements that may cause any benefit, advantage, or solution to occur or become more pronounced, however, are

not to be construed as critical, required, or essential features or elements of any or all of the claims.

[0171] Moreover, embodiments and limitations disclosed herein are not dedicated to the public under the doctrine of dedication if the embodiments and/or limitations: (1) are not expressly claimed in the claims; and (2) are or are potentially equivalents of express elements and/or limitations in the claims under the doctrine of equivalents.

What is claimed is:

1. A golf club head comprising:

a body having a front section,

a first restrictor mechanism comprising a first restrictor and coupled to a first portion of the body; and

a weight comprising a first end coupled to the first restrictor mechanism and coupled to the body;

wherein:

the first restrictor comprises a first stiffness; and
the first stiffness is configured to resist a deformation of the first restrictor by the first end of the weight in response to an impact at a first zone of the front section.

2. The golf club head of claim 1, wherein:

the first restrictor is positioned between the first end of the weight and the front section of the body.

3. The golf club head of claim 1, wherein:

the first restrictor is positioned behind the first end of the weight, relative to the front section of the body.

4. The golf club head of claim 1, wherein:

the weight comprises a face aligned substantially parallel to the front section of the body.

5. The golf club head of claim 1, wherein:

the weight comprises a face is aligned substantially perpendicular to the front section of the body.

6. The golf club head of claim 1, wherein:

a center of gravity of the weight is proximate to at least one of:

a center of gravity of the golf club head;
the front section of the golf club head; or
a geometric center of the golf club head.

7. The golf club head of claim 1, wherein:

the weight comprises a post coupled to the body and the weight; and

the post is configured to align the first end of the weight with the first restrictor.

8. The golf club head of claim 1, wherein:

the first restrictor mechanism further comprises:

a second restrictor opposite the first restrictor; and

the first end of the weight is configured to be positioned between the first restrictor and the second restrictor.

9. The golf club head of claim 8, wherein:

the second restrictor comprises a second stiffness;

the first stiffness of the first restrictor is greater than the second stiffness of the second restrictor; and

the second stiffness is configured to permit a deformation of the second restrictor by the first end of the weight in response to an impact at a second zone of the front section.

10. The golf club head of claim 8, wherein:

the first end of the weight is connected to at least one of:

the first restrictor; or

the second restrictor.

11. The golf club head of claim 1, further comprising:

a second restrictor mechanism comprising a second restrictor and coupled to a second portion of the body,

wherein:

the weight comprises a second end coupled to the second restrictor; and

the first end of the weight is coupled to the first restrictor.

12. The golf club head of claim 11, wherein:

the second restrictor comprises a second stiffness;

the first restrictor comprises a first stiffness greater than the second stiffness; and

the second stiffness is configured to permit a deformation of the second restrictor by the second end of the weight in response to the impact at the first zone of the front section.

13. The golf club head of claim 11, wherein:

the first restrictor mechanism further comprises a third restrictor opposite the first restrictor;

wherein:

the first end of the weight is between the first restrictor and the third restrictor;

the third restrictor comprises a second stiffness;

the first stiffness is greater than the second stiffness; and

the second stiffness is configured to permit a deformation of the third restrictor by the first end of the weight in response to an impact at a second zone of the front section.

14. The golf club head of claim 13, wherein:

the second restrictor mechanism further comprises a fourth restrictor opposite the second restrictor;

wherein:

the second end of the weight is between the second restrictor and the fourth restrictor;

the fourth restrictor comprises the first stiffness;

the second restrictor comprises the second stiffness;

the second stiffness is configured to permit a deformation of the second restrictor by the second end of the weight in response to the impact at the second zone of the front section; and

the first stiffness is configured to resist a deformation of the fourth restrictor by the second end of the weight in response to the impact at the first zone of the front section.

15. The golf club head of claim 1, wherein:

the weight comprises a mass cutout.

16. The golf club head of claim 1, further comprising:

a second restrictor mechanism coupled to a second portion of the body substantially opposite the first portion of the body;

a third restrictor mechanism coupled to a third portion of the body between the first portion of the body and the second portion of the body; and

a fourth restrictor mechanism coupled to a fourth portion of the body substantially opposite the third portion of the body;

wherein the weight further comprises:

a second end substantially opposite the first end and coupled to the second restrictor mechanism;

a third end coupled to the third restrictor mechanism; and

a fourth end substantially opposite the third end and coupled to the fourth restrictor mechanism.

17. The golf club head of claim 16, wherein:

the third restrictor mechanism comprises a first hinge pin set with one or more hinge pins coupled to the third end of the weight; and

the fourth restrictor mechanism comprises a second hinge pin set with one or more hinge pins coupled to the fourth end of the weight.

18. The golf club head of claim 1, wherein: the weight further comprises a second end; the first end of the weight is located along a first plane of the weight;

the second end of the weight is located along a second plane of the weight different from the first plane; the golf club head further comprises a second restrictor mechanism coupled to a second portion of the body; and the second end of the weight is configured to be coupled to the second restrictor mechanism.

19. The golf club head of claim 1, wherein: the first restrictor comprises a notch; the first end of the weight comprises a protrusion coupled with the notch of the first restrictor; and the notch of the first restrictor restricts the weight from rotating along a plane substantially parallel to a face of the weight when the protrusion is coupled to the notch.

20. The golf club head of claim 1, wherein: the first restrictor further comprises a restrictor coupler comprising a coupler stiffness; the first stiffness is greater than the coupler stiffness; the first end of the weight is coupled to the restrictor coupler; and the coupler stiffness is configured to permit a deformation of the restrictor coupler by the first end of the weight in response to at least one of: the impact at the first zone of the front section; or an impact at a second zone of the front section.

21. The golf club head of claim 20, wherein: the first restrictor mechanism further comprises a second restrictor opposite the first restrictor; wherein:

the first end of the weight is between the second restrictor and the restrictor coupler of the first restrictor; the second restrictor comprises a second stiffness greater than the coupler stiffness of the restrictor coupler of the first restrictor; and the second stiffness is configured to resist a deformation of the second restrictor by the first end of the weight in response to the impact at the second zone of the front section.

22. The golf club head of claim 1, wherein: the first restrictor mechanism is adjustable relative to the first end of the weight.

23. The golf club head of claim 22, wherein: the first restrictor of the first restrictor mechanism is adjustable from a first position to a second position relative to the first end of the weight.

24. The golf club head of claim 22, wherein: the first restrictor mechanism comprises: a restrictor cap with an inner perimeter; and restrictors along the inner perimeter of the restrictor cap; the first end of the weight is configured to be coupled within the inner perimeter of the restrictor cap and between the restrictors; and positions of the restrictors relative to the first end of the weight are adjustable when the restrictor cap is rotated relative to the first end of the weight.

25. The golf club head of claim 24, wherein: pairs of the restrictors comprise inversely proportional stiffnesses; and

the pairs of the restrictors are positioned opposite each other along the inner perimeter.

26. The golf club head of claim 24, wherein: the restrictors comprise increasing stiffnesses; and the restrictors are positioned along the inner perimeter based on increasing stiffnesses.

27. The golf club head of claim 1, wherein: the first stiffness is adjustable.

28. The golf club head of claim 1, wherein the weight comprises at least one of:

a mass of approximately 20 to 40 grams; or a mass of approximately 10 to 20 percent of a mass of the golf club head.

29. The golf club head of claim 1, wherein: the body comprises at least one of:

a steel material, a titanium material, an aluminum material, or a graphite material;

the weight comprises at least one of:

a tungsten material, a tungsten-epoxy material, a steel material, a copper material, a titanium material, or a bronze material;

and

the first restrictor mechanism comprises at least one of:

a steel material, a titanium material, an aluminum material, a silicon material, a polymer material, or an epoxy material.

30. A method of manufacturing a golf club head, the method comprising:

forming a body;

providing a weight;

providing a first tab coupler coupled to a first region of the body and comprising a first tab; and

coupling a first end of the weight to the first tab;

wherein the weight restricts a rotational tendency of the body upon an interaction between the first end of the weight and the first tab responsive to an impact at a first portion of the body of the golf club head.

31. The method of claim 30, further comprising:

providing a second tab for the first tab coupler opposite the first tab of the first tab coupler; and

positioning the first end of the weight between the first tab and the second tab of the first tab coupler; wherein the second tab permits a greater distortion than the first tab.

32. A golf club comprising:

a face;

a housing;

a golf club shaft coupled to the housing;

a first restrictor coupled to a first section within the housing;

a second restrictor coupled to the first section within the housing;

a weight comprising a first end between the first restrictor and the second restrictor within the housing; and

a third restrictor coupled to a second section within the housing and to the weight;

wherein:

the second restrictor comprises a second stiffness;

the first restrictor comprises a first stiffness greater than the second stiffness;

the first stiffness is configured to resist a distortion of the first restrictor by the first end of the weight in response to an impact at a first portion of the face of the golf club head; and

the second stiffness is configured to allow a distortion of the second restrictor by the first end of the weight in response to an impact at a second portion of the face of the golf club head.

33. The golf club of claim **32**, wherein:

the first restrictor impedes a rotational tendency of the weight relative to the housing when the housing is rotated in a first direction in response to the impact at the first portion of the face of the golf club.

34. The golf club of claim **33**, wherein:

the first restrictor is neutral with respect to impeding a rotational tendency of the weight relative to the housing when the housing is rotated in a second direction in response to the impact at the second portion of the face of the golf club.

35. The golf club of claim **32**, wherein:

a center of gravity of the weight is substantially collinear with a gravitational vector through a center of gravity of the golf club head.

36. The golf club of claim **32**, wherein:

at least one of the first restrictor and the second restrictor is adjustable relative to the first end of the weight.

* * * * *