

08 C 1110

FILED

FEBRUARY 22, 2008

MICHAEL W. DOBBINS
CLERK, U.S. DISTRICT COURT

**IN THE UNITED STATES DISTRICT COURT
FOR THE NORTHERN DISTRICT OF ILLINOIS
EASTERN DIVISION**

08 C 1110

SASO GOLF, INC.,)	
)	
Plaintiff,)	
)	
v.)	
)	
NIKE, INC.)	
)	Jury Trial Demanded
Defendant.)	

**JUDGE MANNING
MAGISTRATE JUDGE NOLAN**

COMPLAINT

Plaintiff Saso Golf, Inc. (“Saso Golf”), by its attorneys, complains of defendant Nike, Inc. (“Nike” or “Defendant”) and alleges as follows:

Parties

1. Saso Golf is an Illinois corporation with a principal office located in Chicago, Illinois.
2. On information and belief, Defendant Nike is an Oregon corporation with a principal place of business located at One Bowerman Drive, Beaverton, Oregon.

Jurisdiction and Venue

3. This action is an action for patent infringement under the laws of the United States, Title 35 of the United States Code, as set forth below.
4. This Court has subject matter jurisdiction over the claims in this action pursuant to 28 U.S.C. §1338(a).
5. Personal jurisdiction and venue are proper in this judicial district pursuant to 28 U.S.C. § 1400 (b) because Defendant resides and does business in this judicial district and because it has committed acts of infringement in this judicial district.

Count I - Patent Infringement

6. Plaintiff repeats and realleges each and every allegation contained in paragraphs 1 – 5, with the same force and effect as if fully set forth herein.

7. On July 8, 1997, United States Patent No. 5,645,495 entitled “GOLF CLUB,” a copy of which is attached as Exhibit A, was duly and legally issued. Saso Golf owns the full right, title and interest in and to United States Patent No. 5,645,495.

8. In violation of 35 U.S.C. § 271, Defendant makes, uses, offers to sell, sells and/or imports products that infringe United States Patent No. 5,645,495.

9. United States Patent No. 5,645,495 was publicly available and on information and belief, Defendant has been fully aware of U.S. Patent No. 5,645,495 since at least February 26, 2006.

10. On information and belief, with full knowledge of U.S. Patent No. 5,645,495, Defendant willfully continues to make, use, offer to sell, sell and/or import products that infringe United States Patent No. 5,645,495. Defendant will continue its infringement unless enjoined by this Court.

Count II - Patent Infringement

11. Plaintiff repeats and realleges each and every allegation contained in paragraphs 1 – 5, with the same force and effect as if fully set forth herein.

12. On September 16, 2003, United States Patent No. 6,620,055 entitled “GOLF CLUB,” a copy of which is attached as Exhibit B, was duly and legally issued. Saso Golf owns the full right, title and interest in and to United States Patent No. 6,620,055.

13. In violation of 35 U.S.C. § 271, Defendant makes, uses, offers to sell, sells and/or imports products that infringe United States Patent No. 6,620,055.

14. United States Patent No. 6,620,055 was publicly available and on information and belief, Defendant has been fully aware of U.S. Patent No. 6,620,055 since at least February 26, 2006.

15. On information and belief, with full knowledge of U.S. Patent No. 6,620,055, Defendant willfully continues to make, use, offer to sell, sell and/or import products that infringe United States Patent No. 6,620,055. Defendant will continue its infringement unless enjoined by this Court.

Relief Sought

WHEREFORE, Plaintiff Saso Golf respectfully requests that the Court grant the following relief:

- a. A preliminary and permanent injunction preventing infringement by the Defendant of U.S. Patent Nos. 5,645,495 and 6,620,055;
- b. Damages of lost profits, but in no event less than a reasonable royalty, to the maximum extent permitted by law, for Defendant's past and current infringement of U.S. Patent Nos. 5,645,495 and 6,620,055;
- c. An award of treble damages and attorney's fees by reason of Defendant's willful infringement of U.S. Patent No. 5,645,495 and 6,620,055;
- d. An award of interest, including prejudgment interest;
- e. An assessment of costs and disbursements of this action; and
- f. Such other and further relief as justice and equity may require.

Jury Demand

Plaintiff Saso Golf hereby demands trial by jury.

Respectfully submitted,

SASO GOLF, INC.

February 22, 2008

/s/Mark K. Suri

By: One of Its Attorneys

James D. Ryndak #2435942
Mark K. Suri #6199636
Eric H. Weimers #6205977
RYNDAK & SURI LLP
200 W. Madison Street
Suite 2100
Chicago, IL 60606
Phone: 312-214-7770
Fax: 312-214-7715

United States Patent [19]
Saso

[11] **Patent Number:** **5,645,495**
 [45] **Date of Patent:** **Jul. 8, 1997**

- [54] **GOLF CLUB**
- [75] **Inventor:** **Mitsuhiro Saso, Kanzaki-gun, Japan**
- [73] **Assignee:** **Himeji Lodge Hakuba Co., Ltd.,
Himeji, Japan**
- [21] **Appl. No.:** **479,142**
- [22] **Filed:** **Jun. 7, 1995**

3,625,517	12/1971	Durnack	273/167 F
3,655,188	4/1972	Solheim	473/290
3,751,035	8/1973	Lockwood	473/290
3,759,527	9/1973	Witherspoon	273/175
4,211,416	7/1980	Swanson	
4,367,878	1/1983	Schmidt	273/175
4,438,931	3/1984	Motomiya	273/167 H
4,471,961	9/1984	Masghati	273/175
4,725,062	2/1988	Kinney	273/175
4,854,581	8/1989	Long	473/290
5,011,151	4/1991	Antonious	473/350
5,242,167	9/1993	Antonious	473/350

Related U.S. Application Data

- [63] Continuation of Ser. No. 321,588, Oct. 11, 1994, abandoned, which is a continuation of Ser. No. 962,586, filed as PCT/JP92/00303 Mar. 13, 1992 published as WO92/19327 Nov. 12, 1992, abandoned.

Foreign Application Priority Data

- May 1, 1991 [JP] Japan 3-130375
- Dec. 21, 1991 [JP] Japan 3-355888

- [51] **Int. Cl.⁶** **A63B 53/04**
- [52] **U.S. Cl.** **473/345; 473/349**
- [58] **Field of Search** 273/167 R, 168, 273/78, 169, 170, 171, 172, 173, 174, 175, 167 A, 77 A, 77 R, 193 R, 194 R, 194 B, 164.1, 187.4, 186.2; 473/324-350

References Cited

U.S. PATENT DOCUMENTS

1,299,014	4/1919	O'Hara	273/175
1,503,291	7/1924	Rimmer	273/169 X
1,524,731	2/1925	Davis	273/175
1,525,148	2/1925	Pickop	273/169
1,657,473	1/1928	Howard	273/175 X
1,671,956	5/1928	Sime	273/169 X
1,683,639	9/1928	Vaile	273/169 X
2,023,885	12/1935	Hinckley	273/175 X
2,395,837	3/1946	Baymiller	273/175
2,683,036	7/1954	Klein	
3,020,048	2/1962	Carroll	273/175 X
3,068,011	12/1962	Sano	273/169 X
3,419,275	12/1968	Winkleman	273/171
3,595,577	7/1971	Hodge	273/167 G X

FOREIGN PATENT DOCUMENTS

211781	12/1957	Australia	273/167 F
238646	10/1960	Australia	273/167 F
54-116079	8/1979	Japan	
60-85769	5/1985	Japan	
61-159961	10/1986	Japan	
62-59059	4/1987	Japan	
64-43278	2/1989	Japan	

Primary Examiner—Sebastiano Passaniti
Attorney, Agent, or Firm—Smith Patent Office

[57] **ABSTRACT**

A golf club for improving the flying distance of a ball overcomes toe-down phenomenon due to pulling of the shaft particularly by a skilled player enjoying a high head speed. The golf club further improves the head speed and the directional stability of a hit ball. The golf club has a center of gravity of the head shifted from the toe end of the shaft end by modifying the head shape to decrease the volume of the head by a certain amount at the toe end on the rear side thereof and to increase the head volume at the shaft end on the rear side by an amount equal to the decreased amount. This will reduce the rotational radius of the head about a vertical line, as a rotational center line, when the golf club is suspended at the upper end of the shaft. Furthermore, with a metal wood club, a head is provided with a face which comprises a spherical face formed in such a manner that the curvature in the transverse width direction becomes substantially equal to that in the vertical width direction.

7 Claims, 8 Drawing Sheets

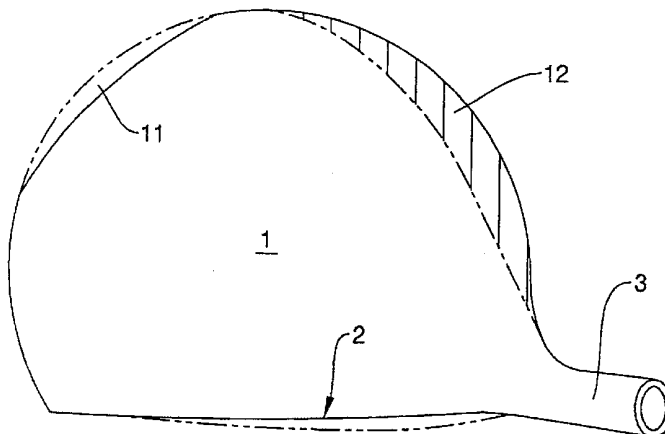

FIG. 1

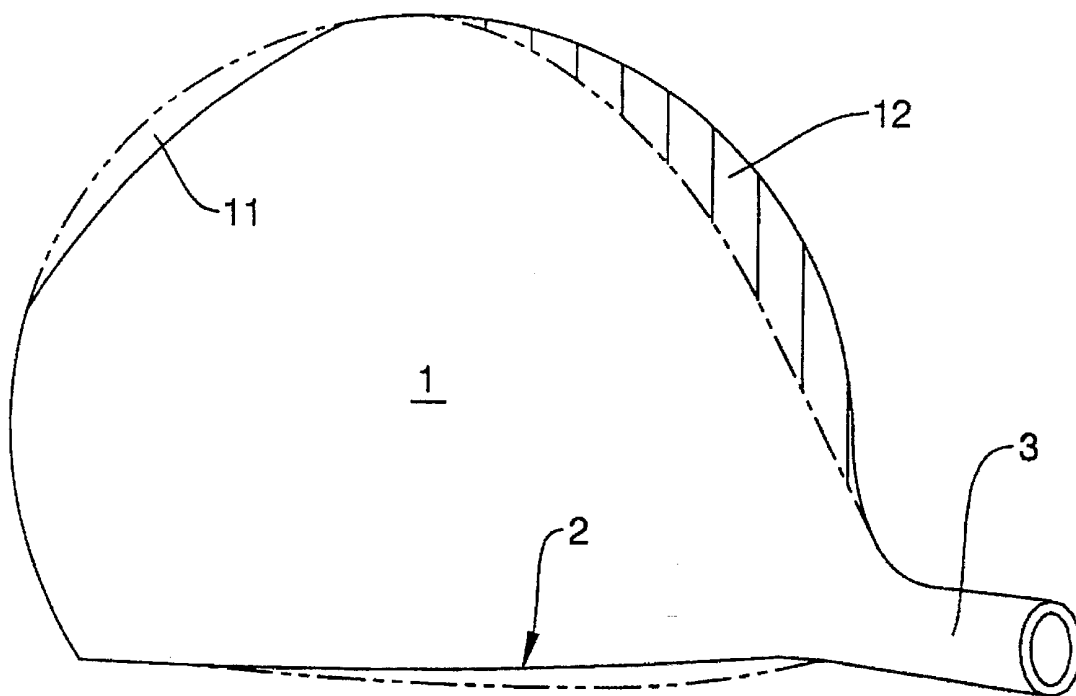

FIG. 2

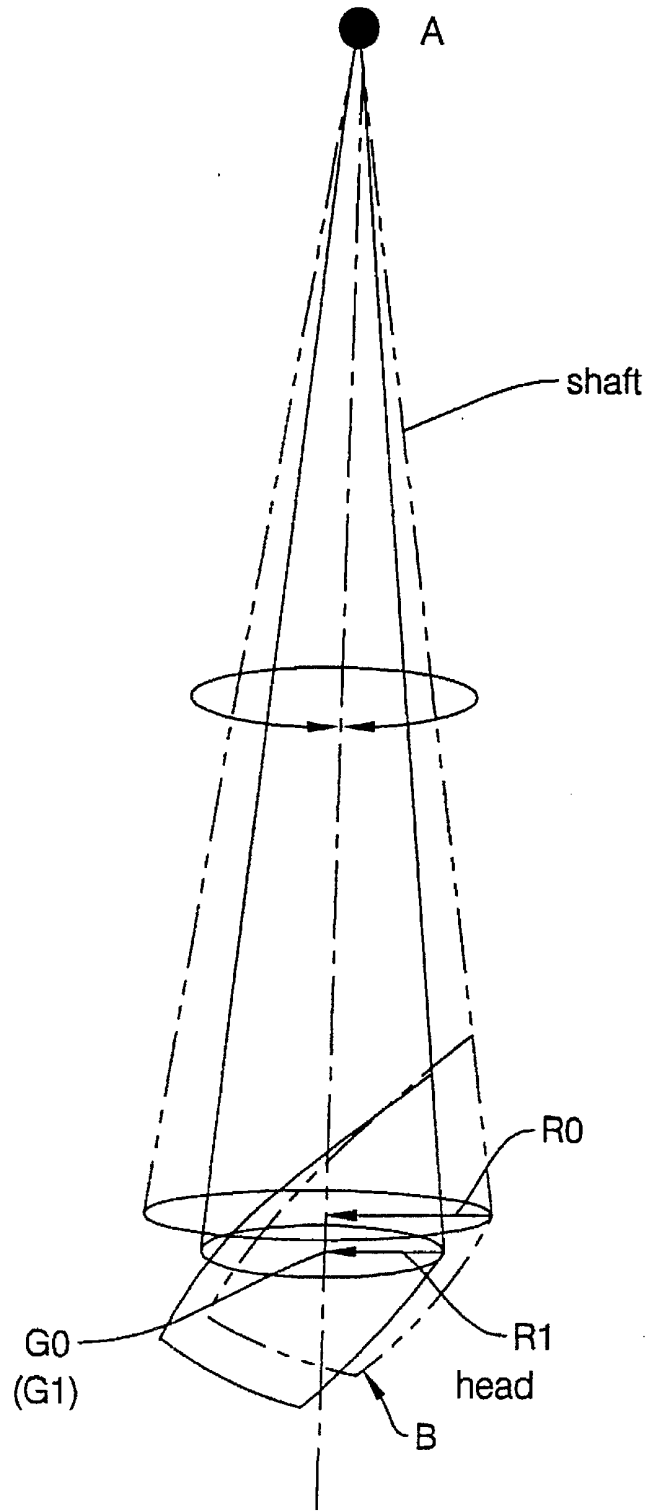

FIG. 3A

covering motion

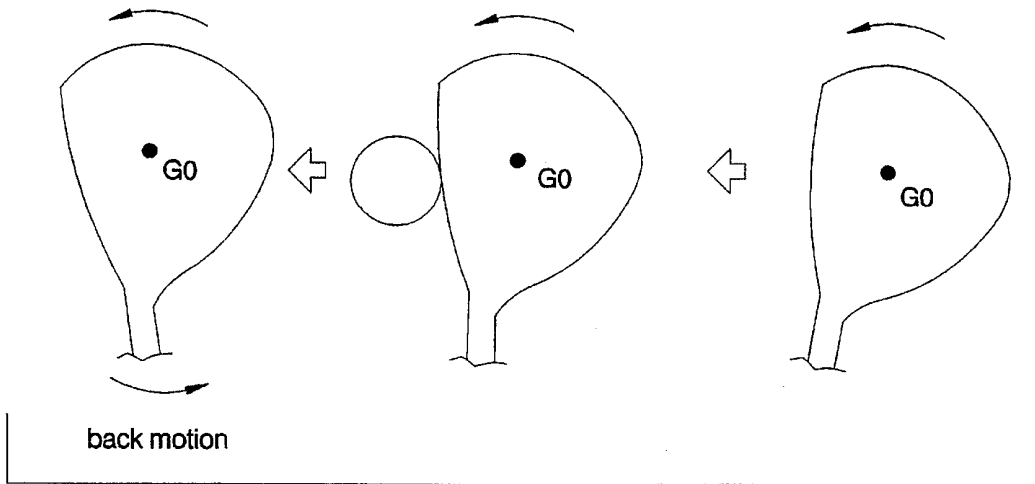

FIG. 3B

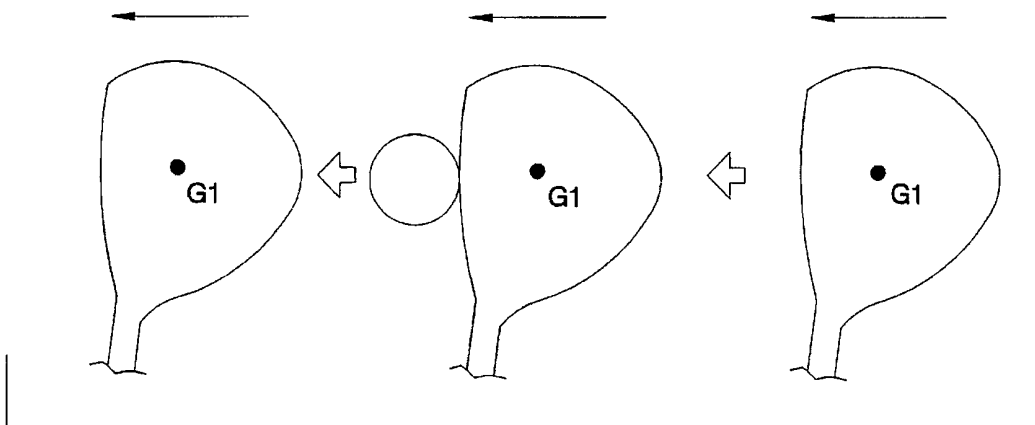

FIG. 4

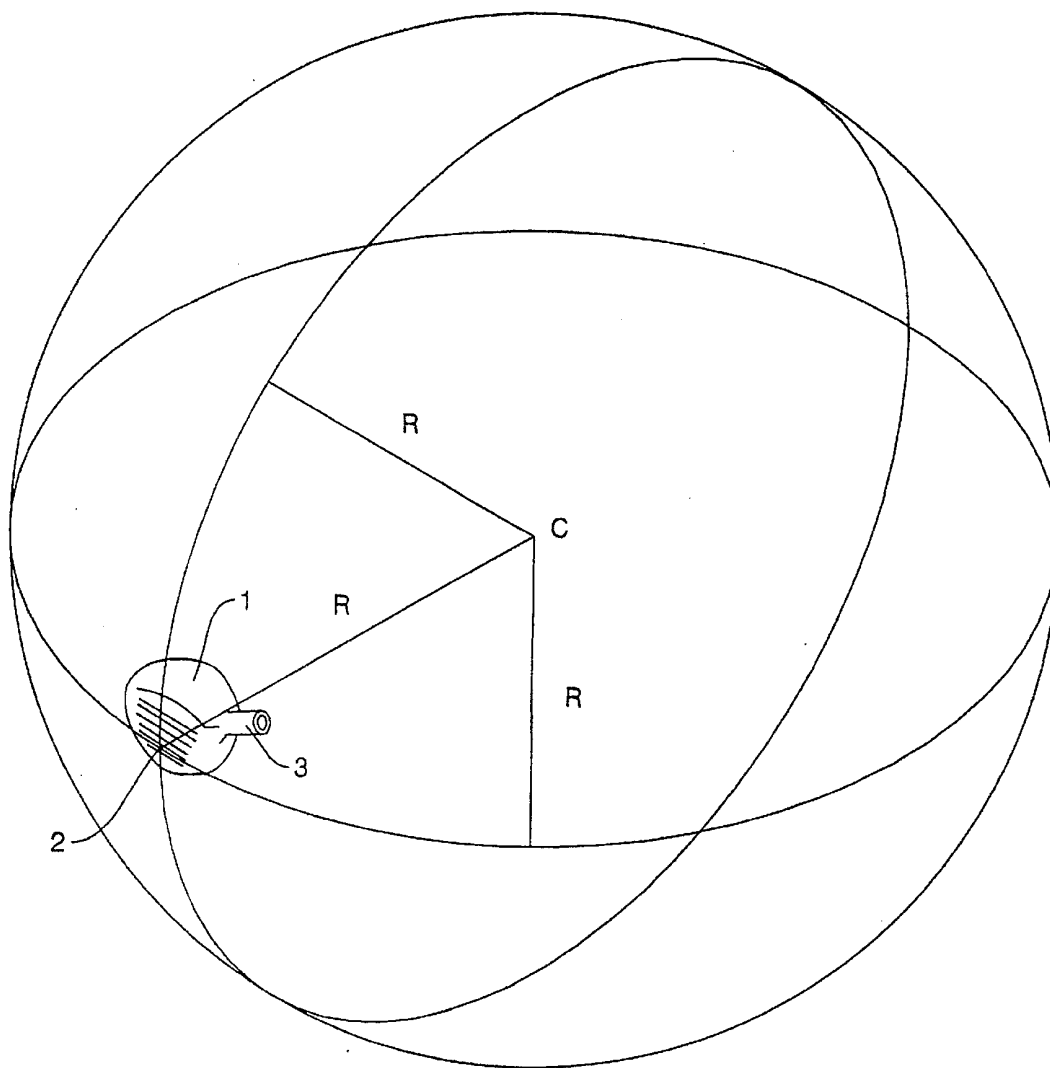

FIG. 5

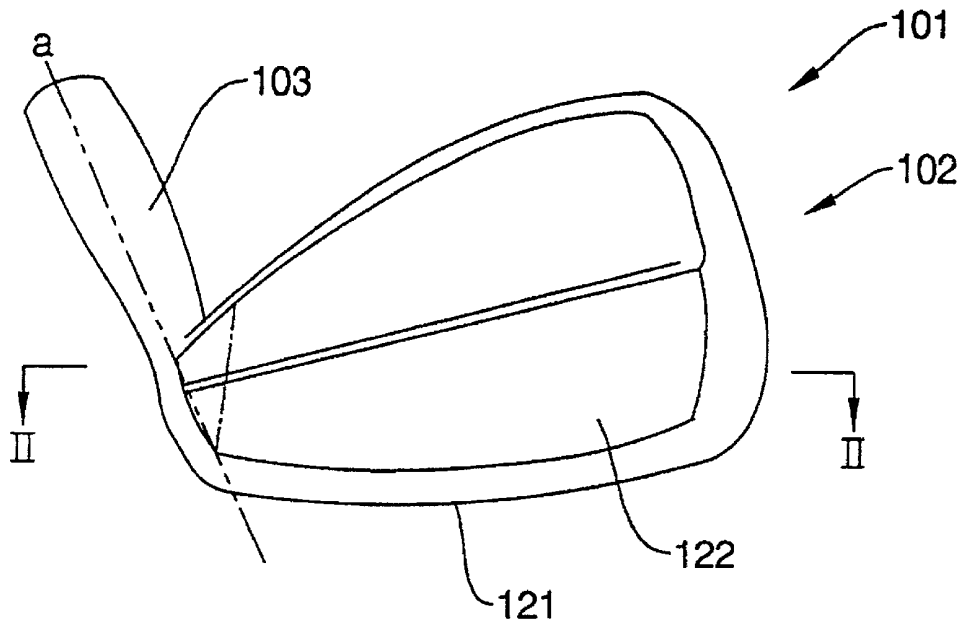

FIG. 6

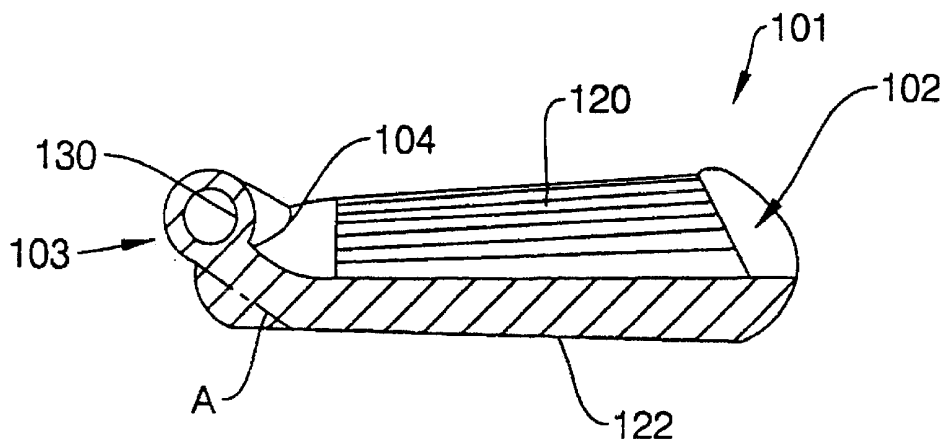

FIG. 7

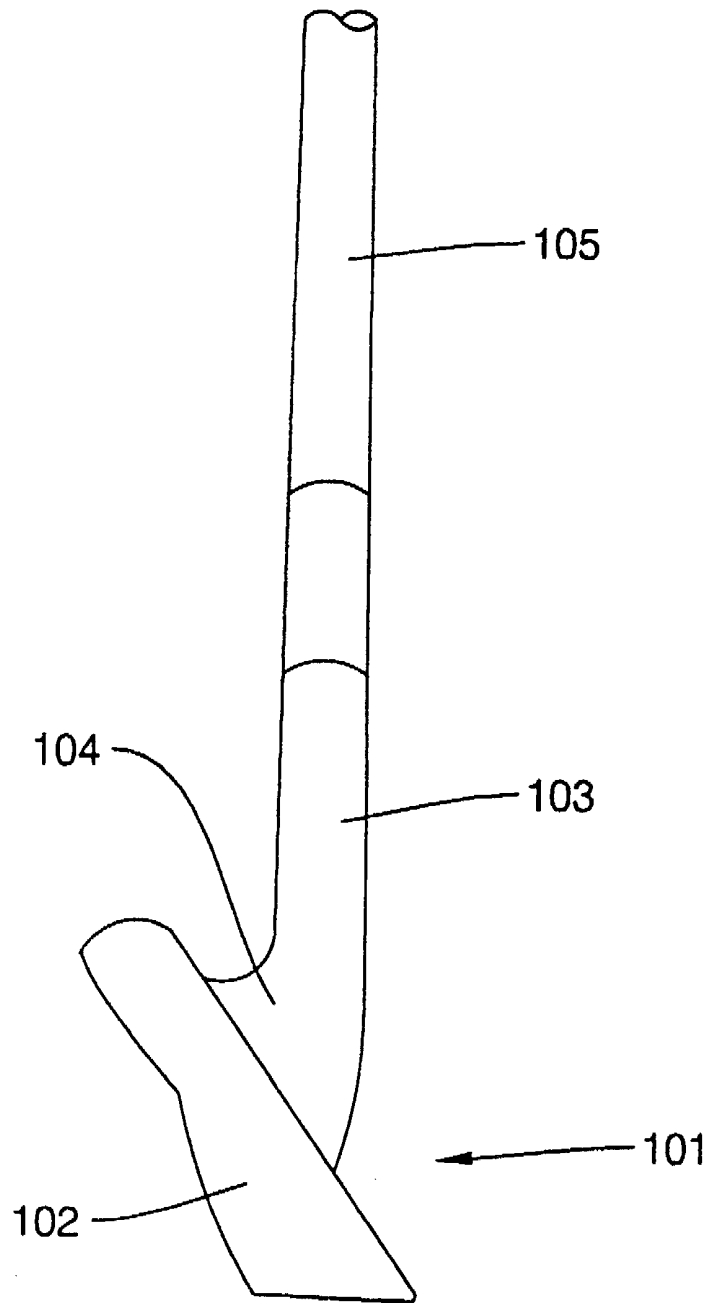

FIG. 8

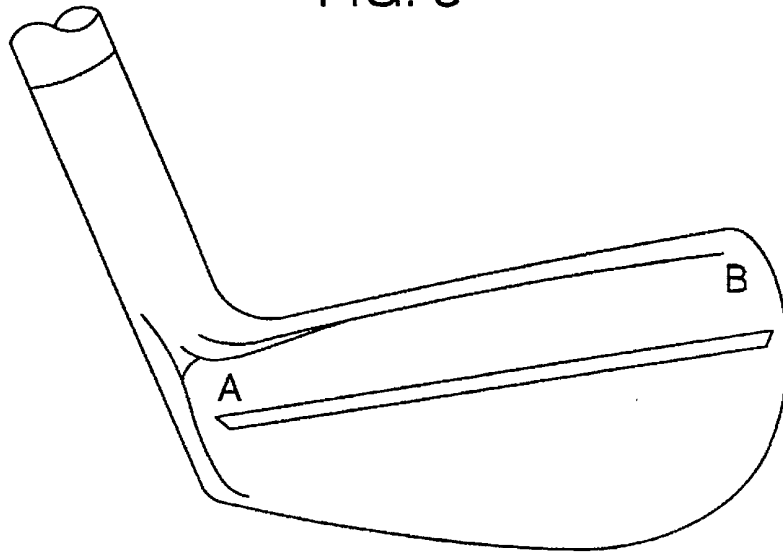

FIG. 9

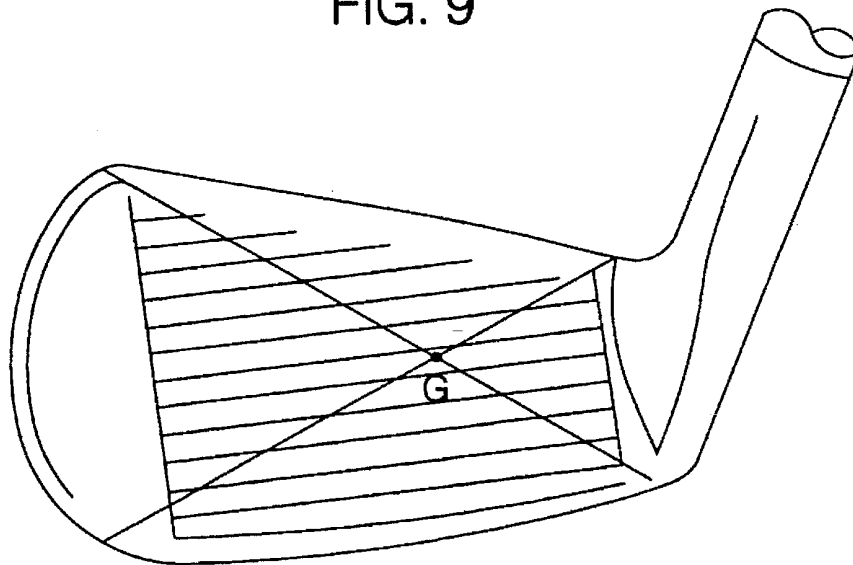

FIG. 10

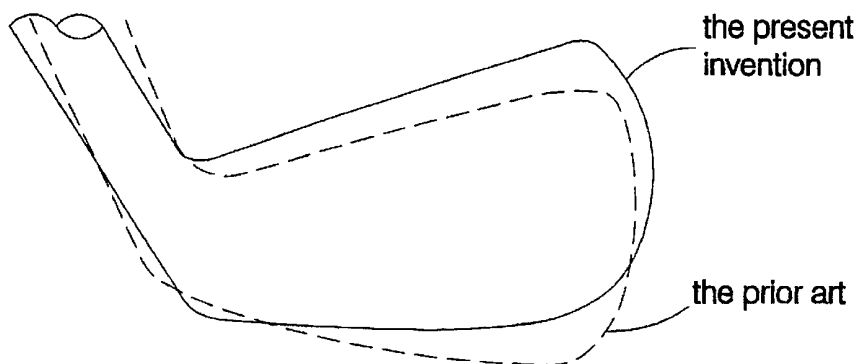

FIG. 11A
the prior art

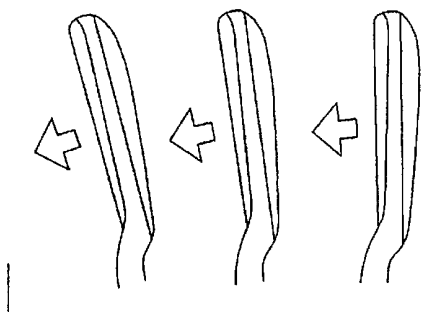
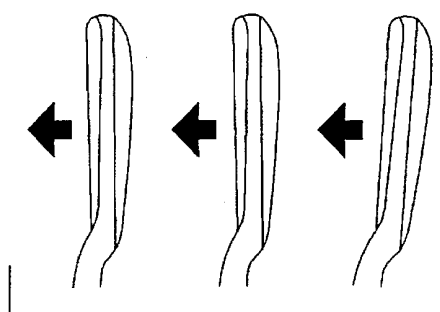

FIG. 11B
the present invention



5,645,495

1

GOLF CLUB

This application is a continuation, of application Ser. No. 08/321,588 filed on Oct. 11, 1994, now abandoned, which is a Continuation application of Ser. No. 07/962,586 filed on Dec. 30, 1992 which was abandoned.

BACKGROUND OF THE INVENTION**1. Field of the Invention**

The present invention relates to a golf club by which the directional stability and flight distance of a shot ball can be improved.

2. Description of the Related Art

In a conventional wooden club, as well as to a metal wood club, a head is in such a shape that, as shown by two dashed line in FIG. 1, it gradually expands from a shaft side to a toe side. The center of gravity of the head is set at a position inclined toward the toe side rather than the center of the projection plane of the head, thereby the head speed of the golf club may be increased at the time of impacting on the ball.

Also in a conventional golf club of an iron type, according to the similar theory, an end of the back side of a club face part is, when seen from a plane, smoothly connected to the hosel, through a neck part, forming a curve (See dashed line A in FIG. 6) and thus the center of gravity of the club is set at a position slightly inclined toward a toe side.

However, when the center of gravity of the head inclines toward the toe side, as shown by two dashed line in FIG. 2, and when the head B is rotated with holding an end A of the club shaft, a radius R_0 of the rotation, with its center line of the rotation positioned at the vertical line made by suspending an upper end of the shaft, increases. Therefore, the metal wood club and the iron club, as shown in FIGS. 3(a) and 11(a), respectively, are apt to cause covering motion (which means the phenomenon that the toe side goes fast than the shaft side as if the toe side rotates around the shaft side) at each head toe side just before impacting.

For the purpose of inhibiting a hook flying of the shot ball, caused by the covering motion, in the metal wood club, as shown by two dashed line in FIG. 1, a head face surface usually has such a shape that the shaft side expands slightly more forward than the toe side. Accordingly, curvature along the transverse direction of the face surface and curvature along longitudinal direction of the face surface are not the same; usually curvature along longitudinal direction is larger than that along the transverse direction.

On the other hand, as shown in FIG. 10, the covering motion is not the only problem in the iron club; that is, the center of gravity of the iron club slightly inclines toward the toe side in the club face part, therefore for advanced golfers whose down swings are faster than those of beginners, a toe down phenomenon, in which the neck part is twisted downwardly by an accelerated motion applied to the head and thus the toe side of the club face part tends to be lowered, resulting in a duff shot.

SUMMARY OF THE INVENTION

Accordingly, for the purpose of overcoming the defects of the conventional club head, the inventor, as a result of his sharp research, has converted the basic concept of designing the club head to a new one in order to provide a golf club head by which improvement in the directional stability and flight distance of the shot ball can be realized. That is the object of the present invention.

2

The present invention has been completed on the inventive concept that due to the property of the sling motion of the club head round the gravity center thereof, in which a heavier part goes forward and a lighter part does not catch up with the heavier part in a manner that the heavier part and the lighter part rotate around the gravity center axis, the conventional club head is subjected not only to the above-mentioned covering movement but also to a pull-back phenomenon in the shaft side as a reaction of the covering movement, accordingly resulting in substantial decrease of the speed of the head. The present invention is, therefore, to provide a golf club which head is formed in such a manner that the amount of a shaft side is increased as much as the amount of a head toe side is decreased so as to shift the center of gravity of the head toward the shaft side and a radius of a rotation, with its center line of the rotation positioned at a vertical line made by suspending an upper end of a shaft, is decreased.

Mere shift of the center of gravity of the head toward the shaft side is not enough to overcome the covering motion of the head; at the same time, the weight balance of the head must be maintained. Therefore, it is advantageous to increase the amount of the shaft side in the head as much as that of the toe side decreases so as to maintain the weight balance of the head. Due to this, the center of gravity of the head usually inclines toward the shaft area by the amount having been shifted.

According to the present invention, as shown by solid line in FIG. 2, since the center of gravity of the head inclines toward the shaft side, when the head is rotated by holding the end of the club shaft, the radius SLAYING of the rotation is smaller than the conventional radius R_0 of the rotation. Moreover due to the increased amount of the shaft side, with use of the sling motion in which the heavier part tends to go forward and the lighter part tends to be pulled backward just before impact, as shown in FIG. 3(b), it is difficult to cause the covering motion apt to take place in the toe side and the draw phenomenon apt to take place in the shaft side, which results in the improvement in the speed of the head upon giving the impact.

In applying the present invention to a metal wood club, the curvatures along the transverse direction and along the longitudinal direction of the face surface are substantially the same. Since the flight direction of the shot golf ball is dominated by both curvatures along the transverse direction and along the longitudinal direction of the face surface of a point where the impact is given, when the curvatures are not the same, the flight direction is not controlled to a desired direction. In the present invention, however, the covering motion of the head at the time of the impact is inhibited by shifting the center of gravity of the head toward the shaft side, resulting in the head face surface is formed by a sphere having substantially the same curvatures along both directions of the face surface, which spherical face is most suitable for giving an impact causing the shot ball controlled. Moreover, since it is difficult to cause the covering motion of the head upon giving an impact, the shot ball tends to direct to the extension of the line connecting the center C of spherical body defining the spherical face and the position where the impact was given, by which superior directional stability of the shot ball is ensured.

In applying the present invention to an iron club, it is preferable to form a back side 122 of a club face part 102 by extending the back side 122 until it passes through the center axis (a) of the hosel part 103 (See FIG. 6), and moreover it is preferable to increase thickness A of the back side 122 by shifting a part of the weight of the toe side B (See FIG. 8).

5,645,495

3

Due to this, although the design is out of the conventional common knowledge in the light of the conventional toe-heel balance, the center of gravity is located at, or almost at the intersection point of diagonals passing across the club face part, by which good balance is maintained, return of the toe in hitting a ball is suppressed by 70% and the cause for duffing can be solved (See FIG. 11). Therefore secure down strokes can be ensured. Moreover in light of the design, thickness of a blade can be increased, by which sufficient spinning shot ball can be made.

Further, since the center of gravity is located at, or almost at the intersection point of diagonals passing across the club face part, different from the conventional iron, a toe down phenomenon apt to take place upon giving an impact can be overcome (See FIG. 10) and the weight distribution suitable for the motion going in and out from a heel is completed, resulting in prevention of mistakes caused by duffing.

In the present invention, when the club face part 2 is designed so as to slightly open by about 1.5° against the ball upon addressing, the defect of the conventional club, in which the head easily turns after the impact and therefore golfers are apt to duff (See FIG. 11(a)), can be overcome. Namely, an impact is given in a slightly open position and immediately after this, the position becomes square and then the head turns little by little, which makes the shot ball fly in a high draw trajectory (See FIG. 11(b)).

Further scope of applicability of the present invention will become apparent from the detailed description given hereinafter. However, it should be understood that the detailed description and specific examples, while indicating preferred embodiments of the invention, are given by way of illustration only, since various changes and modifications within the spirit and scope of the invention will become apparent to those skilled in the art from this detailed description.

BRIEF DESCRIPTION OF THE DRAWINGS

The present invention will become more fully understood from the detailed description given hereinbelow and the accompanying drawings which are given by way of illustration only, and thus are not limitative of the present invention.

FIG. 1 is a plan view comparing the plane shape of a metal head according to the present invention with that of a conventional metal head.

FIG. 2 is a comparative view showing swing motions of wooden clubs with the metal head according to the present invention and with the conventional metal head.

FIG. 3(a) is an explanatory view showing motion of the conventional metal head before and after an impact.

FIG. 3(b) is an explanatory view showing motion of the metal head according to the present invention before and after an impact.

FIG. 4 is a perspective view showing the idea of designing a face surface of the metal head according to the present invention.

FIG. 5 is a rear view showing a head part of an iron club according to the present invention.

FIG. 6 is a sectional view along line II—II in FIG. 5.

FIG. 7 is a front view showing the club according to the present invention.

FIG. 8 is a rear view showing an iron club according to another example of the present invention.

FIG. 9 is a front view showing a position of the center of gravity according to the weight distribution of the present invention.

4

FIG. 10 is a comparative explanatory view showing a toe-down phenomenon in a club according to the present invention (solid line) and in a conventional club.

FIG. 11 is a comparative explanatory view showing a covering motion in an iron club according to the present invention (b) and in a conventional club (a).

DETAILED DESCRIPTION OF THE PREFERRED EMBODIMENTS

The present invention will now be explained in detail, in which the present invention is applied to a metal wood club.

FIG. 1 is a plan view illustrating a projected plane of a metal head according to the present invention, comparing with a conventional metal head. A metal head 1 is a hollow casting, having a spherical face 2 and a hosel part 3 connecting with an unshown shaft. The weight distribution 11 of a toe side is shifted to the back of a shaft side 12 and expanded (See an extent of oblique line). On the whole, the distribution of the amount is not symmetrical, but leans toward the shaft area rather than the toe area. Therefore besides the center of gravity of the head shifts from G0 to the shaft side G1, the distribution of the amount in the shaft side is increased. As a result, the superior weight distribution which, at the moment of giving an impact, suppresses the covering motion in the toe side and the draw phenomenon in the shaft side, can be obtained.

As for the face surface 2, as shown in FIG. 4, the curvature R along the transverse direction and the curvature R along the longitudinal direction are unified and the face 2 surface is so designed that it forms a part of a sphere with radius R round a center C as illustrated. The hosel part 3 obliquely protrudes upward from a position adjacent to the face surface translated in parallel to the center of the sphere. The loft angle of the face surface generally falls on the range from about 9°–12° and both curvatures along the transverse and longitudinal directions of the face are selected from the range from 9–12R so that they are the same. Use of such a golf club makes a golf ball and the face surface collide with each other at the time of impact as if a small ball and a large ball collided with each other and the shot ball is directed to the line extending a radius connecting the spherical center C and the position where the impact was given.

Now the present invention will be explained, in which it is applied to an iron club head.

FIGS. 5 to 7 illustrate an iron golf club according to an example of this invention. A club head 101 is formed by integrally connecting a club face part 102 and a hosel part 103 at a neck part 104. The club head 101 is integrally manufactured with use of an iron material or a copper material by means of forging or casting and polished for finishing.

A fixed hole 130 is formed along the longitudinal direction of the hosel part 103. A shaft 105 is engaged with and fixed to the fixed hole 130 and at the upper side of the shaft, a grip (not shown) is provided.

The club face part 102 comprises a face 120 made open by 1.5° from a square, a sole 121 and a back side 122. As shown in FIG. 5, the back side 122 is formed in such a manner that the back side 122 is extended to a position passing through the center axis (a) of the hosel part 103 and connected to the hosel part 103 through an end surface. The thickness of the back side 122 of the club face part 102, therefore, is increased and compared with the shape of a conventional club head, the neck part is made much smaller. As a result, the weight of the neck part is increased and, as shown in FIG. 9, the center of gravity of the club head is located at or adjacent to an intersection point of diagonals of the face part.

5

Accordingly, when a golfer with this club addresses, even though the club face part 102 is placed in a square position, it looks slightly open. The back side 122 of the club face part 102 is extended to a position passing across the center axis (a) of the hosel part 103. The neck part swells and further the center of gravity of the club face part 102 is positioned at the intersection point of the diagonals and slightly inclines toward a heel side to stabilize the club face part 102. When the club is swung under these conditions, it is easy for a golfer to give an impact to a ball in a square position and fly the ball in a straight direction without a hook or a slice. Moreover even when advanced golfers swing downward at a high speed, since good rigidity around the hosel part 103 is given and the center of gravity of the club face part 102 is located at the intersection point of the diagonals so as to slightly incline toward the heel side, a toe-down phenomenon hardly takes place and it results in a smooth impact without duffing.

The invention being thus described, it will be obvious that the same may be varied in many ways. Such variations are not to be regarded as a departure from the spirit and scope of the invention, and all such modifications as would be obvious to one skilled in the art are intended to be included within the scope of the following claims.

What is claimed is:

1. A golf club comprising:

a metallic wood type head having a heel side and a toe side, the mass of the heel side being increased as much as the mass of the toe side of the head is decreased so as to shift the center of gravity of the head toward the heel side, the head having a portion of a surface shaped such that the curvature of the surface approximates the curvature of a sphere, the portion of the surface of the head having substantially the same curvatures along the transverse direction thereof as along a longitudinal direction thereof;

a shaft having an upper end and lower end, the lower end being connected to the head at the heel side; and

6

said metallic wood type head further comprising a toe, a heel and a back side profile shape extending from the toe side to the heel side, said back side profile shape between the toe and a most rearwardly point of said metallic wood type head having a radius of curvature that is larger than the radius of curvature of said back side profile shape between the most rearwardly point of said metallic wood type head and the heel.

2. The golf club as claimed in claim 1, wherein the head is a hollow casting with a hosel part to which the shaft is connected.

3. The golf club as claimed in claim 2, wherein the hosel part obliquely protrudes upwardly from a position adjacent a face surface of the head.

4. The golf club as claimed in claim 3, wherein the face surface of the head has a loft angle of 9° to 12°.

5. The golf club as claimed in claim 1, wherein the head has a face surface with a loft angle of 9° to 12°.

6. The golf club as claimed in claim 1, wherein the center of gravity of the head is located approximately in a geometric center of the head.

7. A golf club comprising:

a metallic wood type head including a cylindrical hosel portion formed integrally therewith;

said metallic wood type head having a heel side and a toe side, said metallic wood type head having a hitting surface extending from the toe side to said heel side, the hitting surface having substantially the same curvature along a transverse direction as a longitudinal direction,

said metallic wood type head further comprising a toe, a heel, and a back side profile shape extending from the toe side to the heel side, said back side profile shape between the toe and a most rearwardly point of said metallic wood type head having a radius of curvature that is larger than the radius of curvature of said back side profile shape between the most rearwardly point of said metallic wood type head and the heel.

* * * * *

(12) **United States Patent**
Saso

(10) **Patent No.:** **US 6,620,055 B2**
(45) **Date of Patent:** ***Sep. 16, 2003**

(54) **GOLF CLUB**

(75) Inventor: **Mitsuhiko Saso**, Hyogo (JP)
(73) Assignee: **Saso Golf, Inc.**, Chicago, IL (US)
(*) Notice: Subject to any disclaimer, the term of this patent is extended or adjusted under 35 U.S.C. 154(b) by 0 days.
This patent is subject to a terminal disclaimer.

3,700,244 A * 10/1972 Liotta
3,759,527 A 9/1973 Witherspoon
3,908,722 A * 9/1975 Jacobs
3,941,390 A 3/1976 Hussey
4,367,878 A * 1/1983 Schmidt
4,471,961 A * 9/1984 Masghati
4,725,062 A * 2/1988 Kinney
4,766,698 A * 8/1988 Solomko
4,776,594 A * 10/1988 Rango
5,645,495 A * 7/1997 Saso
5,916,043 A * 6/1999 Saso

* cited by examiner

(21) Appl. No.: **09/321,572**

(22) Filed: **May 28, 1999**

(65) **Prior Publication Data**

US 2003/0092500 A1 May 15, 2003

Related U.S. Application Data

(63) Continuation of application No. 08/888,831, filed on Jul. 7, 1997, now Pat. No. 5,916,043, which is a continuation of application No. 08/479,142, filed on Jun. 7, 1995, now Pat. No. 5,645,495, which is a continuation of application No. 08/321,588, filed on Oct. 11, 1994, now abandoned, which is a continuation of application No. 07/962,586, filed as application No. PCT/JP92/00303 on Mar. 13, 1992, now abandoned.

(30) **Foreign Application Priority Data**

May 1, 1991 (JP) 3-130375
Dec. 21, 1991 (JP) 3-355888

(51) **Int. Cl.**⁷ **A63B 53/04**

(52) **U.S. Cl.** **473/324; 473/345; 473/349**

(58) **Field of Search** 473/324, 330,
473/345, 346, 349, 350, 290, 291, 292,
331; D21/733, 759

(56) **References Cited**

U.S. PATENT DOCUMENTS

2,395,837 A * 3/1946 Baymiller

Primary Examiner—Sebastiano Passaniti

(74) *Attorney, Agent, or Firm*—Ryndak & Suri

(57) **ABSTRACT**

A golf club for improving the flying distance of a ball overcomes toe-down phenomenon due to pulling of the shaft particularly by a skilled player enjoying a high head speed. The golf club further improves the head speed and the directional stability of a hit ball. The golf club has a center of gravity of the head shifted from the toe end of the shaft end by modifying the head shape to decrease the volume of the head by a certain amount at the toe end on the rear side thereof and to increase the head volume at the shaft end on the rear side by an amount equal to the decreased amount. This will reduce the rotational radius of the head about a vertical line, as a rotational center line, when the golf club is suspended at the upper end of the shaft. Furthermore, with a metal wood club, a head is provided with a face which comprises a spherical face formed in such a manner that the curvature in the transverse width direction becomes substantially equal to that in the vertical width direction.

5 Claims, 8 Drawing Sheets

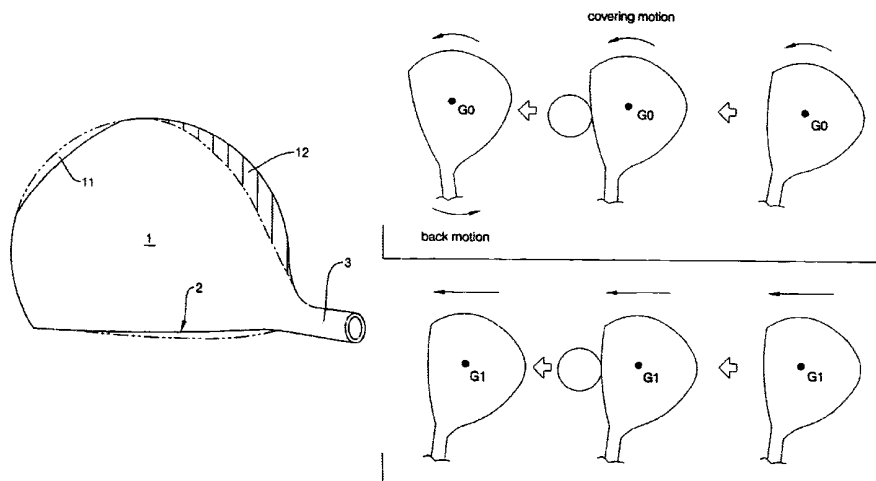

FIG. 1

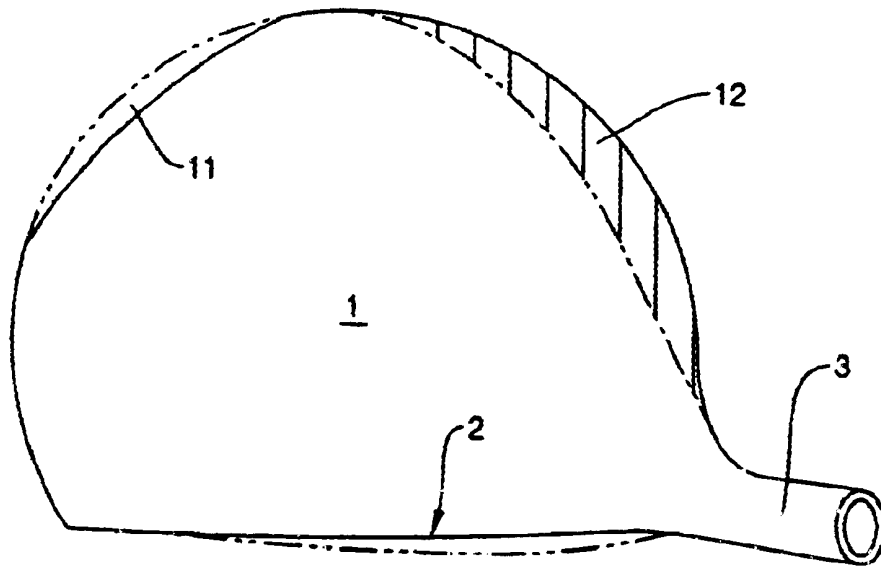

FIG. 2

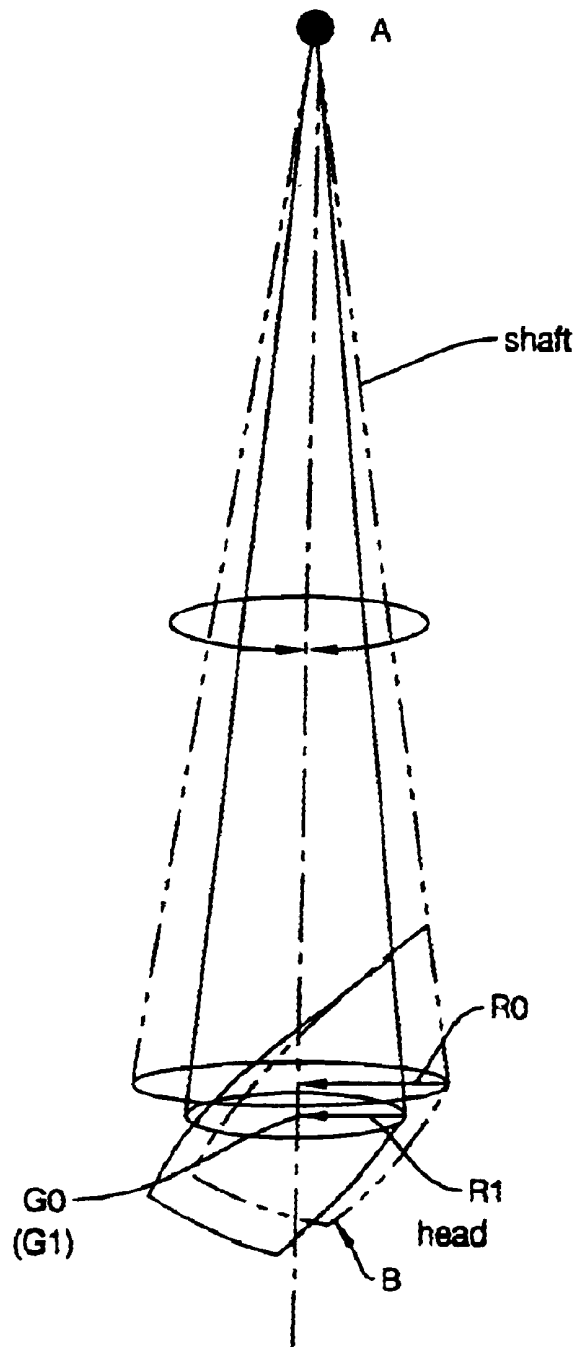

FIG. 3A

covering motion

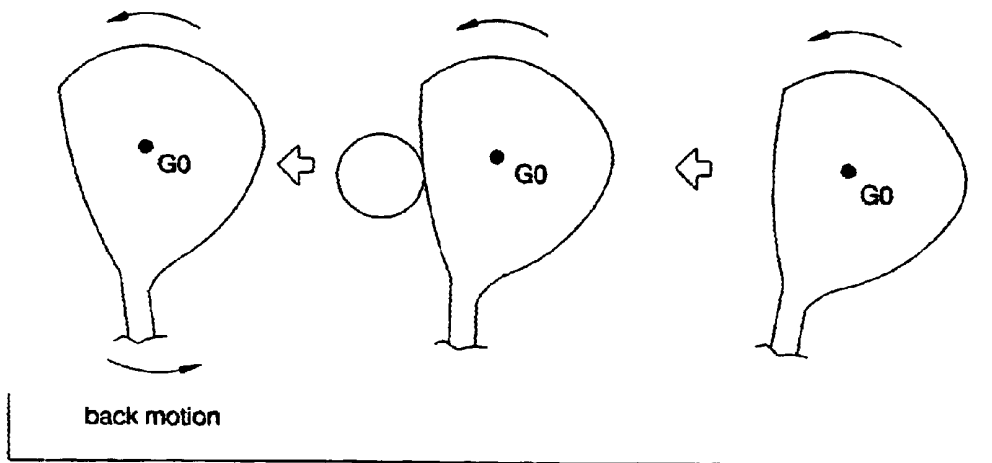

FIG. 3B

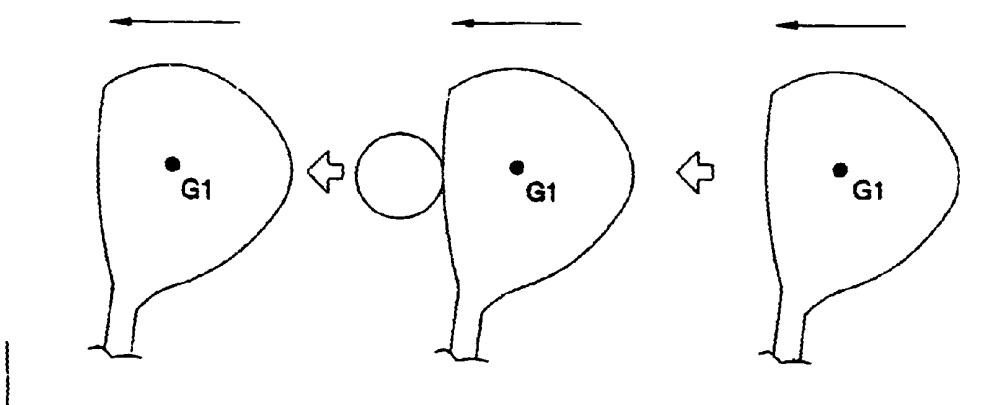

FIG. 4

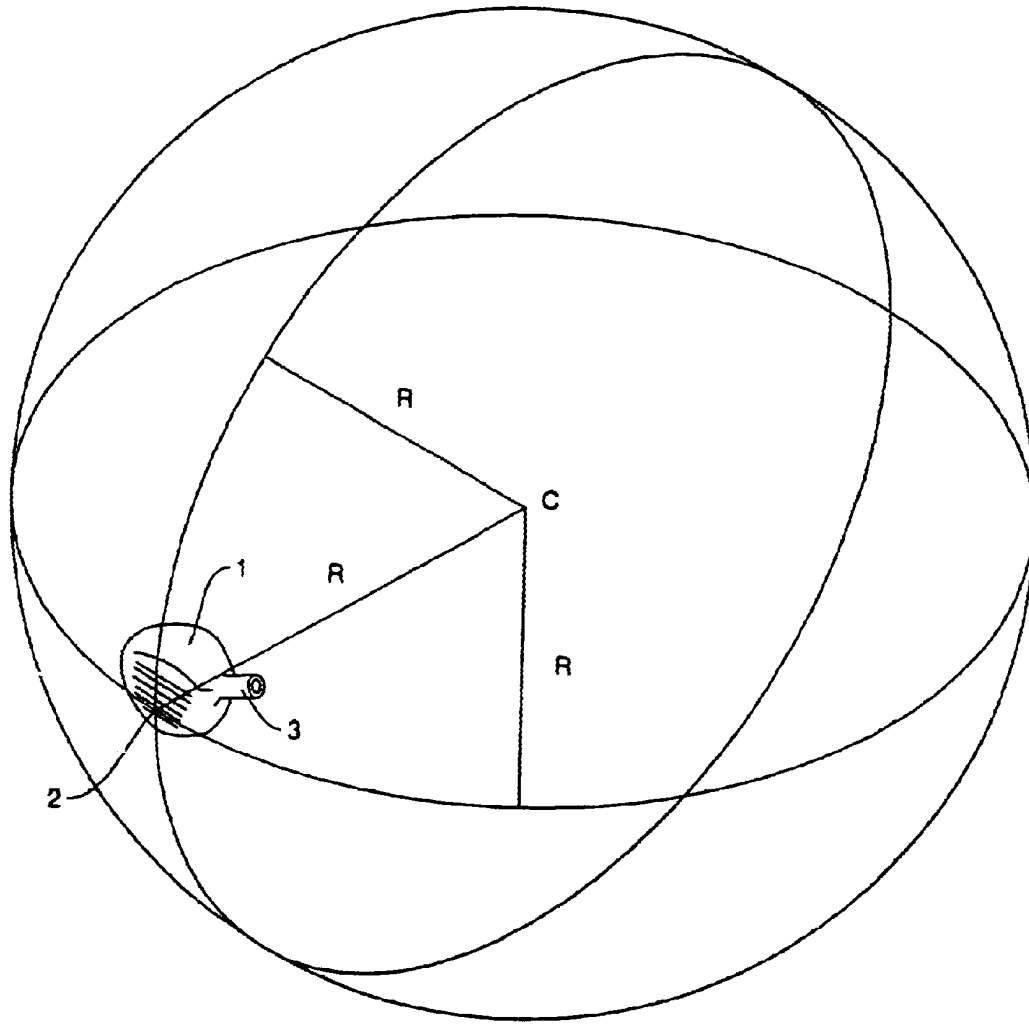

FIG. 5

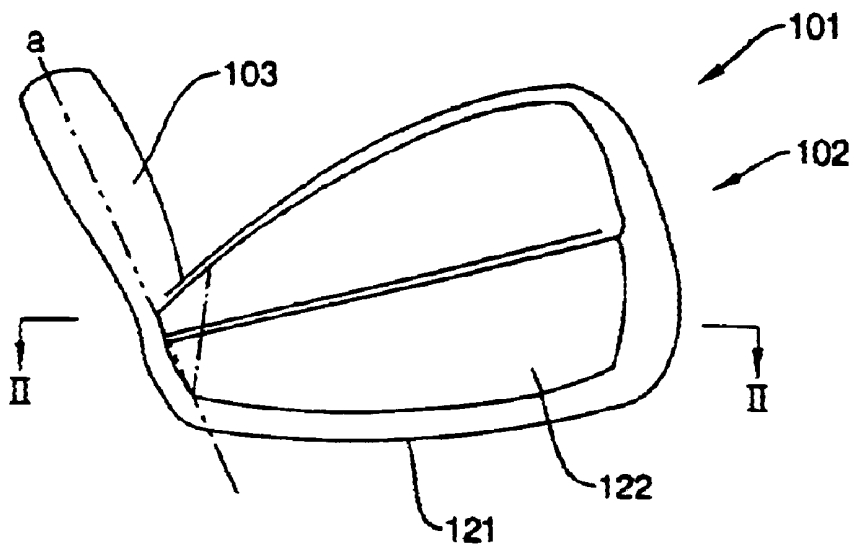

FIG. 6

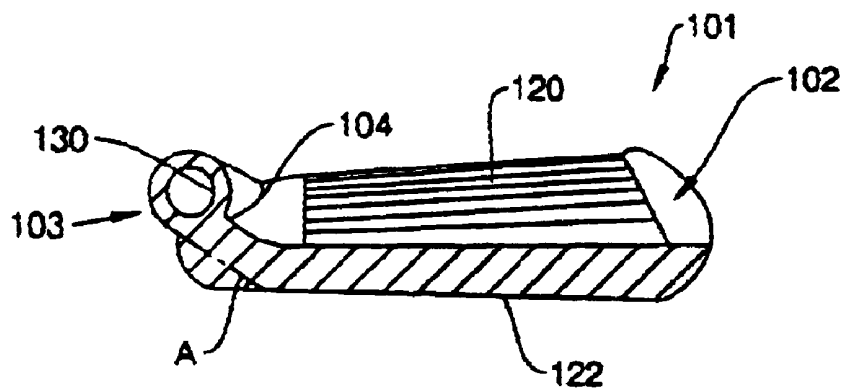

FIG. 7

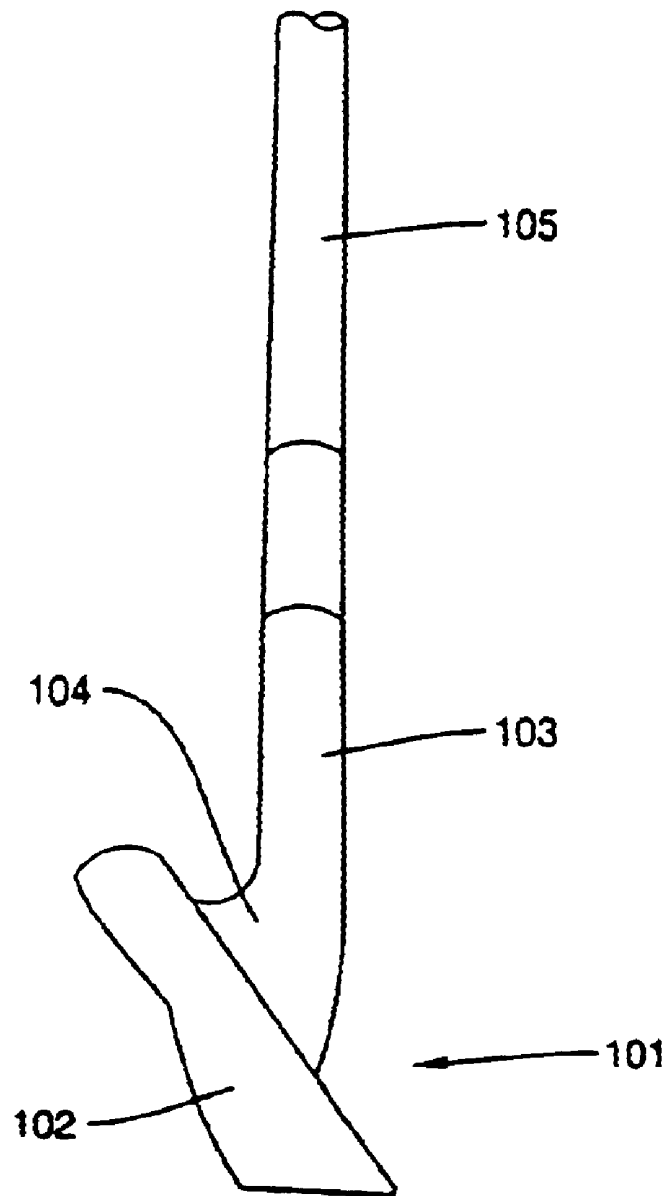

FIG. 8

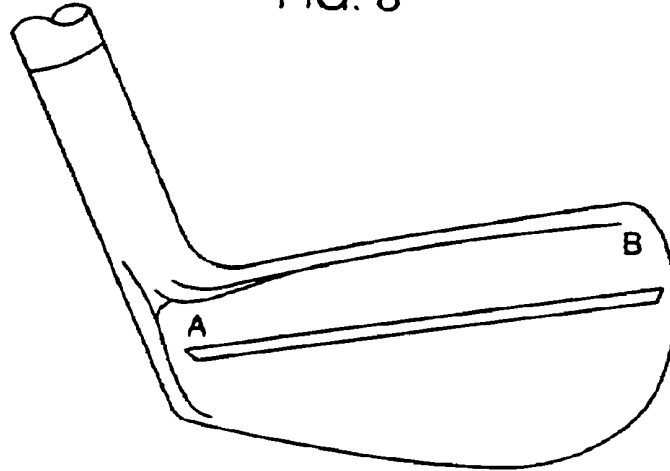

FIG. 9

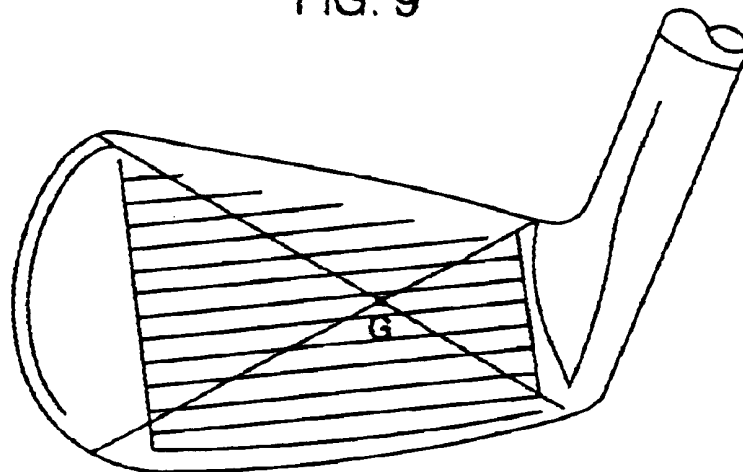

FIG. 10

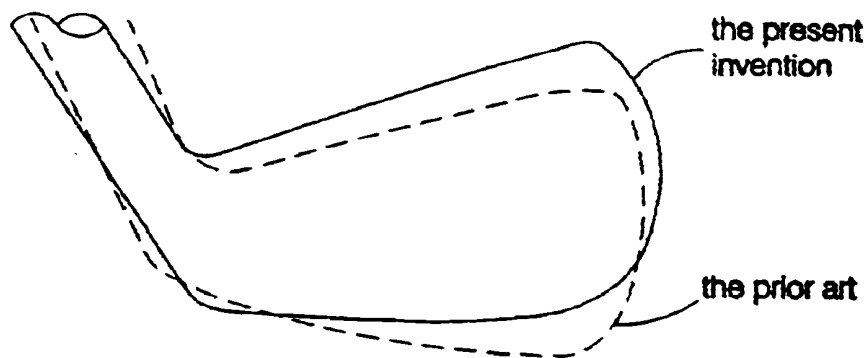

FIG. 11A
the prior art

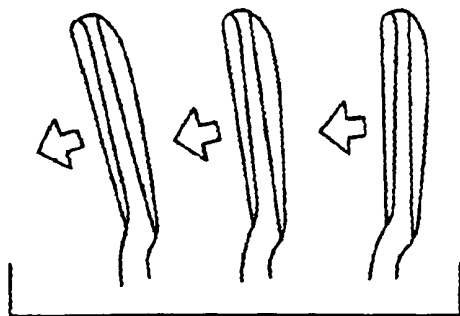
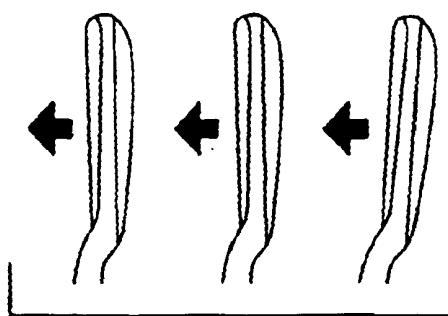

FIG. 11B
the present invention



US 6,620,055 B2

1

GOLF CLUB

This application is a continuation of application Ser. No. 08/888,831 filed on Jul. 7, 1997, now U.S. Pat. No. 5,916,043, which is continuation of application Ser. No. 08/479,142 filed Jun. 7, 1995, now U.S. Pat. No. 5,645,495 issued on Jul. 8, 1997, which is a continuation of application Ser. No. 08/321,588, filed on Oct. 11, 1994, now abandoned, which is a continuation of application Ser. No. 07/962,586 filed Nov. 12, 1992, abandoned as PCT/JP92/00303, Mar. 13, 1992 published as WO92/19327.

TITLE OF THE INVENTION

Golf Club

1. Field of the Invention

The present invention relates to a golf club by which the directional stability and flight distance of a shot ball can be improved.

2. Prior Art

In a conventional wooden club, as well as to a metal wood club, a head is in such a shape that, as shown by two dashed line in FIG. 1, it gradually expands from a shaft side to a toe side. The center of gravity of the head is set at a position inclined toward the toe side rather than the center of the projection plane of the head, thereby the head speed of the golf club may be increased at the time of impacting on the ball.

Also in a conventional golf club of an iron type, according to the similar theory, an end of the back side of a club face part is, when seen from a plane, smoothly connected to the hosel, through a neck part, forming a curve (See dashed line A in FIG. 6) and thus the center of gravity of the club is set at a position slightly inclined toward a toe side.

However, when the center of gravity of the head inclines toward the toe side, as shown by two dashed line in FIG. 2, and when the head B is rotated with holding an end A of the club shaft, a radius R_0 of the rotation, with its center line of the rotation positioned at the vertical line made by suspending an upper end of the shaft, increases. Therefore, the metal wood club and the iron club, as shown in FIGS. 3(a) and 11(a), respectively, are apt to cause covering motion (which means the phenomenon that the toe side goes fast than the shaft side as if the toe side rotates around the shaft side) at each head toe side just before impacting.

For the purpose of inhibiting a hook flying of the shot ball, caused by the covering motion, in the metal wood club, as shown by two dashed line in FIG. 1, a head face surface usually has such a shape that the shaft side expands slightly more forward than the toe side. Accordingly, curvature along the transverse direction of the face surface and curvature along longitudinal direction of the face surface are not the same; usually curvature along longitudinal direction is larger than that along the transverse direction.

On the other hand, as shown in FIG. 10, the covering motion is not the only problem in the iron club; that is, the center of gravity of the iron club slightly inclines toward the toe side in the club face part, therefore for advanced golfers whose down swings are faster than those of beginners, a toe down phenomenon, in which the neck part is twisted downwardly by an accelerated motion applied to the head and thus the toe side of the club face part tends to be lowered, resulting in duff shot.

Accordingly, for the purpose of overcoming the defects of the conventional club head, the inventor, as a result of his sharp research, has converted the basic concept of designing

2

the club head to a new one in order to provide a golf club head by which improvement in the directional stability and flight distance of the shot ball can be realized. That is the object of the present invention.

The present invention has been completed on the inventive concept found by us that due to the property of the sling motion of the club head round the gravity center thereof, in which a heavier part goes forward and a lighter part does not catch up with the heavier part in a manner that the heavier part and the lighter part rotate around the gravity center axis, the conventional club head is subjected not only to the above-mentioned covering movement but also to a pull-back phenomenon in the shaft side as a reaction of the covering movement, accordingly resulting in substantial decrease of the speed of the head. The present invention is, therefore, to provide a golf club which head is formed in such a manner that the amount of a shaft side is increased as much as the amount of a head toe side is decreased so as to shift the center of gravity of the head toward the shaft side and a radius of a rotation, with its center line of the rotation positioned at a vertical line made by suspending an upper end of a shaft, is decreased.

Mere shift of the center of gravity of the head toward the shaft side is not enough to overcome the covering motion of the head; at the same time, the weight balance of the head must be maintained. Therefore, it is advantageous to increase the amount of the shaft side in the head as much as that of the toe side decreases so as to maintain the weight balance of the head. Due to this, the center of gravity of the head usually inclines toward the shaft area by the amount having been shifted.

According to the present invention, as shown by solid line in FIG. 2, since the center of gravity of the head inclines toward the shaft side, when the head is rotated by holding the end of the club shaft, the radius R_0 of the rotation is smaller than the conventional radius R_0 of the rotation. Moreover due to the increased amount of the shaft side, with use of the sling motion in which the heavier part tends to go forward and the lighter part tends to be pulled backward just before impact, as shown in FIG. 3(b), it is difficult to cause the covering motion apt to take place in the toe side and the draw phenomenon apt to take place in the shaft side, which results in the improvement in the speed of the head upon giving the impact.

In applying the present invention to a metal wood club, the curvatures along the transverse direction and along the longitudinal direction of the face surface are substantially the same. Since the flight direction of the shot golf ball is dominated by both curvatures along the transverse direction and along the longitudinal direction of the face surface of a point where the impact is given, when the curvatures are not the same, the flight direction is not controlled to a desired direction. In the present invention, however, the covering motion of the head at the time of the impact is inhibited by shifting the center of gravity of the head toward the shaft side, resulting in that the head face surface is formed by a sphere having substantially the same curvatures along both directions of the face surface, which spherical face is most suitable for giving an impact causing the shot ball controlled. Moreover, since it is difficult to cause the covering motion of the head upon giving an impact, the shot ball tends to direct to the extension of the line connecting the center C of spherical body defining the spherical face and the position where the impact was given, by which superior directional stability of the shot ball is ensured.

In applying the present invention to an iron club, it is preferable to form a back side 122 of a club face part 102 by

US 6,620,055 B2

3

extending the back side **122** until it passes through the center axis (a) of the hosel part **103** (See FIG. 6), and moreover it is preferable to increase thickness A of the back side **122** of a neck part **4** by shifting a part of the weight of the toe side B (See FIG. 8). Due to this, although the design is out of the conventional common knowledge in the light of the conventional toe-heel balance, the center of gravity is located at, or almost at the intersection point of diagonals passing across the club face part, by which good balance is maintained, return of the toe in hitting a ball is suppressed by 70% and the cause for duffing can be solved (See FIG. 11). Therefore secure down strokes can be ensured. Moreover in the light of the design, thickness of a blade can be increased, by which sufficient Spinning shot ball can be made.

Further, since the center of gravity is located at, or almost at the intersection point of diagonals passing across the club face part, different from the conventional iron, a toe down phenomenon apt to take place upon giving an impact can be overcome (See FIG. 10) and the weight distribution suitable for the motion going in and out from a heel is completed, resulting in prevention of mistakes caused by duffing.

In the present invention, when the club face part **2** is designed so as to slightly open by about 1.5° against the ball upon addressing, the defect of the conventional club, in which the head easily turns after the impact and therefore golfers are apt to duff (See FIG. 11(a)), can be overcome. Namely, an impact is given in a slightly open position and immediately after this, the position becomes square and then the head turns little by little, which makes the shot ball to fly in a high draw trajectory (See FIG. 11(b)).

BRIEF DESCRIPTION OF THE DRAWINGS

FIG. 1 is a plane view comparing the plane shape of a metal head according to the present invention with that of a conventional metal head.

FIG. 2 is a comparative view showing swing motions of wooden clubs with the metal head according to the present invention and with the conventional metal head.

FIG. 3(a) is an explanatory view showing motion of the conventional metal head before and after an impact.

FIG. 3(b) is an explanatory view showing motion of the metal head according to the present invention before and after an impact.

FIG. 4 is a perspective view showing the idea of designing a face surface of the metal head according to the present invention.

FIG. 5 is a rear view showing a head part of an iron club according to the present invention.

FIG. 6 is a sectional view along—line in FIG. 5.

FIG. 7 is a schematical perspective view showing the club according to the present invention.

FIG. 8 is a rear view showing an iron club according to another example of the present invention.

FIG. 9 is a front view showing a position of the center of gravity according to the weight distribution of the present invention.

FIG. 10 is a comparative explanatory view showing a toe-down phenomenon in a club according to the present invention (solid line) and in a conventional club.

FIG. 11 is a comparative explanatory view showing a covering motion in an iron club according to the present invention (a) and in a conventional club (b).

PREFERRED EMBODIMENT

The present invention will now be explained in detail, in which the present invention is applied to a metal wood club.

4

FIG. 1 is a plane view illustrating a projected plane of a metal head according to the present invention, comparing with a conventional metal head. A metal head **1** is a hollow casting, having a spherical face **2** and a hosel part **3** connecting with an unshown shaft. The weight distribution **11** of a toe side is shifted to the back of a shaft side **12** and expanded (See an extent of oblique line). On the whole, the distribution of the amount is not symmetrical, but leans toward the shaft area rather than the toe area. Therefore besides the center of gravity of the head shifts from **G0** to the shaft side **G1**, the distribution of the amount in the shaft side is increased. As a result, the superior weight distribution which, at the moment of giving an impact, suppresses the covering motion in the toe side and the draw phenomenon in the shaft side, can be obtained.

As for the face surface **2**, as shown in FIG. 4, the curvature **R** along the transverse direction and the curvature **R** along the longitudinal direction are unified and the face **2** surface is so designed that it forms a part of a sphere with radius **R** round a center **C** as illustrated. The hosel part **103** obliquely protrudes upward from a position adjacent to the face surface translated in parallel to the center of the sphere. The loft angle of the face surface generally falls on the range from about 90°–120° and both curvatures along the transverse and longitudinal directions of the face are selected from the range from 9–12R so that they are the same. Use of such a golf club makes a golf ball and the face surface collide with each other at the time of impact as if a small ball and a large ball collided with each other and the shot ball is directed to the line extending a radius connecting the spherical center **C** and the position where the impact was given.

Now the present invention will be explained, in which it is applied to an iron club head.

FIGS. 4 to 7 illustrate an iron golf club according to an example of this invention. A club head **101** is formed by integrally connecting a club face part **102** and a hosel part **103** at a neck part **104**. The club head **101** is integrally manufactured with use of an iron material or a copper material by means of forging or casting and polished for finishing.

A fixed hole **130** is formed along the longitudinal direction of the hosel part **103**. A shaft **105** is engaged with and fixed to the fixed hole **130** and at the upper side of the shaft, a grip (not shown) is provided.

The club face part **102** comprises a face **120** made open by 1.5° from a square, a sole **121** and a back side **122**. As shown in FIG. 5, the back side **122** is formed in such a manner that the back side **122** is extended to a position passing through the center axis (a) of the hosel part **103** and connected to the hosel part **103** through an end surface. The thickness of the back side **122** of the club face part **102**, therefore, is increased and compared with the shape of a conventional club head, the neck part is made much smaller. As a result, the weight of the neck part is increased and, as shown in FIG. 9, the center of gravity of the club head is located at or adjacent to an intersection point of diagonals of the face part.

Accordingly, when a golfer with this club addresses, even though the club face part **102** is placed in a square position, it looks slightly open. The back side **122** of the club face part **102** is extended to a position passing across the center axis (a) of the hosel part **103**. The neck part swells and further the center of gravity of the club face part **102** is positioned at the intersection point of the diagonals and slightly inclines toward a heel side to stabilize the club face part **102**. When the club is swung under these conditions, it is easy for a

US 6,620,055 B2

5

golfer to give an impact to a ball in a square position and fly the ball in a straight direction without a hook or a slice. Moreover even when advanced golfers swing downward at a high speed, since good rigidity around the hosel part 103 is given and the center of gravity of the club face part 102 is located at the intersection point of the diagonals so as to slightly incline toward the heel side, a toe-down phenomenon hardly takes place and it results in a smooth impact without duffing.

What is claimed is:

1. A golf club comprising:

a metallic wood type head having a heel side and a toe side;

a shaft having an upper end and lower end, the lower end being connected to the head at the heel side; and

said metallic wood type head further comprising a toe, a heel and a back side profile shape extending from the toe side to the heel side, said back side profile shape between the toe side and a most rearwardly point of said metallic wood type head having a radius of curvature that is larger than the radius of curvature of said back side profile between the most rearwardly point of said metallic wood type head and the heel side.

2. A golf club as defined in claim 1, wherein the head has a portion of a surface shaped such that the curvature of the

6

surface substantially approximates the curvature of a sphere for striking a golf ball.

3. A golf club as defined in claim 2, wherein the portion of the surface of the head has substantially the same curvatures along the transverse direction thereof as along a longitudinal direction thereof.

4. A method of striking a golf ball comprising:

(a) swinging the golf club in a golf swing, the golf club comprising a golf shaft having an upper end and a lower end, and the head having a toe, a heel and a back side profile shape extending from the toe side to the heel side, the back side profile shape between the toe and a most rearwardly point of the head having a radius of curvature that is larger than the radius of curvature of the back side profile shape between the most rearwardly point of the head and the heel; and

(b) striking the golf ball with the golf ball striking face of the golf club during the golf swing.

5. The method of claim 4 wherein the head further comprises a ball striking face with a longitudinal extent and a transverse extent, the face having a spherical ball striking surface that approximates the curvature of a sphere, the spherical surface having substantially the same curvature in the transverse direction as in the longitudinal direction.

* * * * *